



Item No. _____

L810

Electric Two-Sided Grill

L810



Model G810 Includes grooved upper platen.

Features

One touch menu selection automatically provides accurate TIME, TEMPERATURE, and GAP settings for every product.

Programmable Controls

Microprocessor controls are programmable for simplified operator operation. Offers flexibility for future menu items and product specification changes at the restaurant level. Customizable to offer multi-stage settings per product, five languages (English, Spanish, French, Russian and Portuguese), standby alert to conserve energy, and four timers that can be used specifically for flat grill cooking.

External USB Port

External USB port allows user access to upload new menu and promotional items. Menu changes can be sent electronically to other store locations saving time and eliminating operator error.

Upper Platens

Three upper platens will close automatically to the preset gap setting with the touch of one button. Air cylinder system provides quiet, simple, trouble-free operation of the upper platen. As a safety feature, platen will automatically open at loss of power, or if an obstruction is detected.

Precise Automatic Gapping

Solid platform with 3-point reference plane and fixed (home) reference point. Once programmed, the upper platen automatically achieves accurate and consistent gaps, every time. Precise, repeatable gapping assures product safety and better quality finished product.

Cooking Zones

Three separately controlled cooking zones. Each zone has three independent heating elements, and two in the upper platen to assure even temperatures and quick recovery.

Side-To-Side Release Material

Protects entire upper platen cooking surface and makes cleaning easy. Improved installation and removal process away from hot surfaces.

Patty Cook Position Placement Guide

Lower cooking surface is etched for a permanent patty placement guide for two-sided cooking.

Optional Weighted Platens- 3 Phase Models Only

The weighted platen is designed to compress a fresh hand formed product to a patty, while maintaining the juices and quality of the product along with the desired sear.

Approval Mark Note: The Approval marks shown may not apply to every model configuration. Approvals may vary based on Voltage, Model Option and Accessory selection, please contact your local distributor for more information.

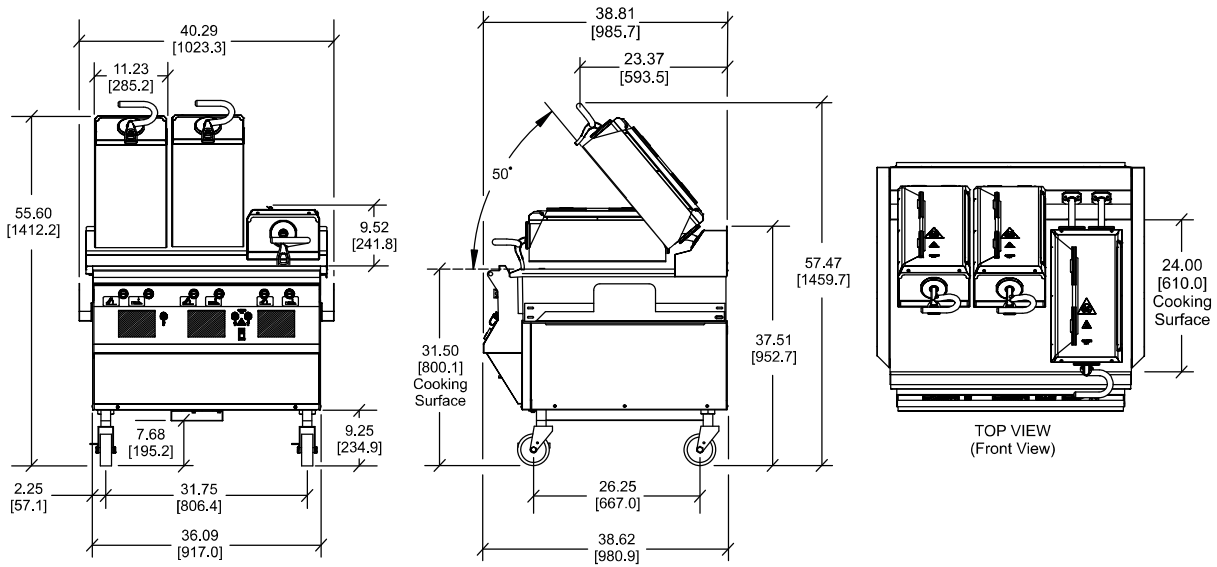

FIGURES IN BRACKETS INDICATE MILLIMETERS / DECIMAL AND FRACTIONAL DIMENSIONS EQUAL TO (PLUS OR MINUS 1/16 INCH [1.5mm]), MACHINE HEIGHT CAN VARY (PLUS OR MINUS 2.5 INCHES [63.5 MM]) WITH CASTER HEIGHT ADJUSTMENT / SIDE GREASE CANS NOT SHOWN.

Weights	lbs.	kgs.
Net	870/**1040	394.6/**465.7
Crated	1035/**1205	469.4/**546.6

***weighted platen model

	cu. ft.	cu. m.
Volume	53.7	1.52

Dimensions	in.	mm.
Width	40-5/16	1024
Depth	38-13/16	986
Height	55 to 60	1397 to 1524
Cooking Surface Height	29 to 34	737 to 864
Floor Clearance	5-3/16 to 10-3/16	132 to 259

Casters may be adjusted.

Electrical	Amps Per Cord	Total kW	Cord Supplied with NEMA Plug
*208/60/3***	38 (2) 39	25	NEMA 15-50P (2)
*240/60/3	33 (2) 38	27 25	NEMA 15-50P (2)
200/50/60/3	37 (2) 33	25	NEMA 15-50P (2)
400/50/3N~***	16 (2) 19	22.5	**
400/50/3N~	13 (3)	22.5	**
230/400/60/3	19 (2)	22.5	**

** Plug supplied by customer ***Weighted platen model available voltage

* ENERGY STAR qualified model

This unit may be manufactured in other electrical characteristics and may have additional regulatory agency approvals. Consult the local Taylor Distributor for other electrical characteristics and agency approvals based on specific electrical and country requirements.

(For exact electrical information and approval marks, always refer to the data label of the unit.)

Continuing research results in steady improvements; therefore, these specifications are subject to change without notice.

Bidding Specs

Electrical: Volt _____ Hz _____ ph _____
 Neutral: Yes No **Cooling:** Air Water NA

Options: _____

Authorized Taylor Distributor

Specifications

Electrical

See the Electrical chart for the proper electrical requirements. Manufactured to be permanently connected. Consult your local Taylor distributor for receptacle specifications as local codes allow. Restraining cable included.

Accessories

- Cleaner (1qt)
- Grease cans (two, mount on each side)

Minimum clearance from construction:

Allow for a 34"(86.4cm) minimum aisle width in front of grill

- Release sheets; includes clips and retainer (one box of 9)
- Squeegee (one)

Options

- Cleaning Pads (10 qty.)
- Cleaning Pad Holder
- Gap Gage (0.255)
- Grill Scraper
- Tool Holder
- Weighted Platens



750 N. Blackhawk Blvd.
 Rockton, Illinois 61072
 www.taylor-company.com