



Optional Cart with front opening door



Simplified Pump

Item No. _____

C708 Shake

Shake Freezer

Single Flavor, Pump, Heat Treatment

Features

Serve classic thick shakes. Direct draw a single flavor, or blend in flavoring for more variety. Viscosity is continually measured to ensure finished product consistency.

Heat Treatment System

Provides a daily heating and cooling cycle to safely maintain dairy products up to 28 days before a complete disassembly and cleaning is required.

Freezing Cylinder

One, 3.4 quart (3.2 liter).

Mix Hopper

One, 20 quart (18.9 liter). Refrigerated to maintain mix below 41°F (5°C) in Auto and Standby modes. Simplified air/mix pump delivers the precise amount of air and mix to the freezing cylinder, and reduces operator parts.

Indicator Lights

Mix Low light alerts the operator to add mix. When the Mix Out light flashes, the unit automatically goes into Standby mode to prevent damage.

Touch Screen Controls

Microprocessor touch controls are embedded in durable tempered glass panel. Multiple languages are selectable. History of temperatures and times during the last 366 heat cycles may be viewed from the fluorescent display from within the Manager's menu.

Standby

During long no-use periods, the standby feature maintains safe product temperatures in the mix hopper and freezing cylinder.

Door Interlock System

Protects the operator from injury as the beater will not operate without the dispensing door in place.

Approval Mark Note:

The Approval marks shown below may not apply to every model configuration. Approvals may vary based on Voltage, Model Option and Accessory selection, please contact your local distributor for more information.

750 N. Blackhawk Blvd. Rockton, Illinois 61072
800-255-0626
Phone 815-624-8333 Fax 815-624-8000
www.taylor-company.com
info@taylor-company.com

ISO 9001:2015
Registered Firm



Standard 6



LISTED
SA2650



Selected 50
Hz. Models

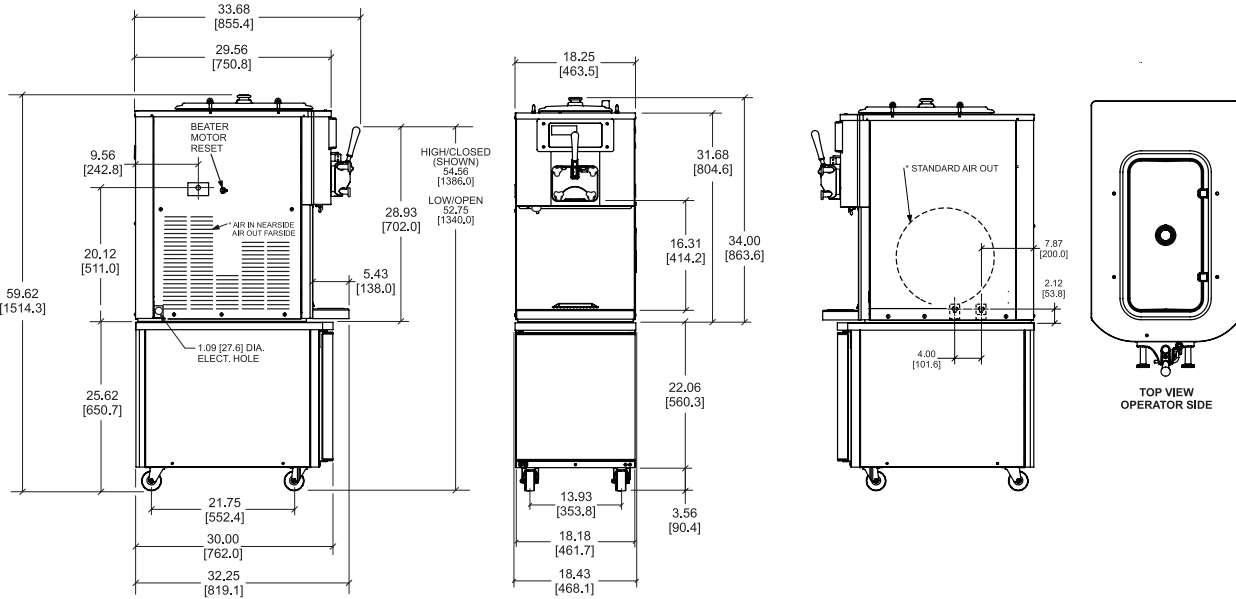

NOTE: FIGURES IN BRACKETS INDICATE MILLIMETERS / DECIMAL AND FRACTIONAL DIMENSIONS EQUAL TO (PLUS OR MINUS 1/16 INCH [1.5mm]).

Weights	lb.	kg
Net	425	192.8
Crated	471	213.6
<i>*For reference only</i>		
Volume	cu. ft.	cu. m
	35.0	0.99
Dimensions	in.	mm
Width	18-1/4	464
Depth	32-1/4	820
Height	34	864

**Designed to rest on a plastic pad directly on the counter top or optional cart.*

Electrical	Maximum Fuse Size	Minimum Circuit Ampacity	Poles (P) Wires (W)
208-230/60/1 Air	25	21	2P 3W
208-230/60/3 Air	20	15	3P 4W
220-240/50/1 Air	25	19	2P 3W
380-415/50/3N~ Air	10	9	4P 5W
208-230V/60Hz/3PH (W/C)	25	21	2P 3W
200V 50/60Hz 3Ph (A/C)	14	13	2P 3W
380-415V 50Hz (W/C)	10	8	3P 4W

This unit may be manufactured with other electrical characteristics and may have additional regulatory agency approvals. Consult the local Taylor distributor for other electrical characteristics and agency approvals based on specific electrical and country requirements.

(For exact electrical information, approval marks, and refrigerant, always refer to the data label of the unit.)

Continuing research results in steady improvements. Therefore, these specifications are subject to change without notice.

Bidding Specs

Electrical: Volt _____ Hz _____ ph _____
 Neutral: Yes No Cooling: Air Water NA

Options: _____

Specifications

Electrical

One dedicated electrical connection is required. See the electrical chart for the proper electrical requirements. Manufactured to be permanently connected. Consult your local Taylor distributor for cord and receptacle specifications as local codes allow.

Beater Motor

One, 1.5 hp.

Refrigeration System

One, 10,100 BTU/hr. R449A.

Air-Cooled

Minimum 6 in. (152 mm) on both sides and place the back of the unit against a wall to prevent recirculation of warm air. Minimum air clearances must be met to ensure adequate airflow for optimum performance.

Water Cooled

Options

- Cart with casters-height to top of hopper cover: 59-5/8 in. (1515 mm)
- Hopper Locks
- Legs - [increase height of unit by 4-1/4 in. (108 mm)]
- C201 Cart Standard Height with Casters
- C201 Cart, Standard Height with Casters, Flavor Burst Ready
- C201 Cart, Standard Height with Casters, Rear Door

All options may not be available in combination with others or with all electrical or cooling configurations. Please consult your local Taylor distributor.

Authorized Taylor Distributor

TAYLOR®
 750 N. Blackhawk Blvd.
 Rockton, Illinois 61072
www.taylor-company.com