

Refrigerated Prep Tables

Models: SKP278, SKP2712, SKEPT4812



Silver King® is the leader in reliable and energy efficient refrigeration solutions. Our sleek, stainless steel refrigeration equipment is made with the highest quality materials to guarantee everything is kept fresh and meets temperature standards. Our equipment has polyurethane insulation for maximum strength and durability and minimal energy waste.

Standard Features

- Exterior stainless steel with galvanized back and bottom.
- Interior aluminum with coved corners and finished edges for easy cleaning.
- Doors have polyurethane insulation, stainless steel exterior and extra heavy duty magnetic "Thermo Rubber" door gaskets, combined to make the toughest, longest lasting door in the industry.
- Heavy gauge wire shelves are hand dipped, not sprayed, providing double thick epoxy coating for superior durability and smooth finish. Adjustable in 1/2" increments on stainless steel pilasters.
- Standard 8 foot 3-wire power cord NEMA 5-15P plug.
- Casters are supplied and are heavy-duty (two with locks) threaded into rivnuts, secured to a 12 gauge steel base to ensure durability.
- CFC-free refrigerant, hermetically sealed, high efficiency, self contained refrigeration system with automatic defrost and forced air circulation.
- Limited Warranty: 1-year labor, 1-year parts, 5-year compressor (part only), 90-days replacement parts. Warranty is determined by the original equipment manufacturing date for general market.*

Specifications

SKP278/C2 (shown), SKP2712/C2

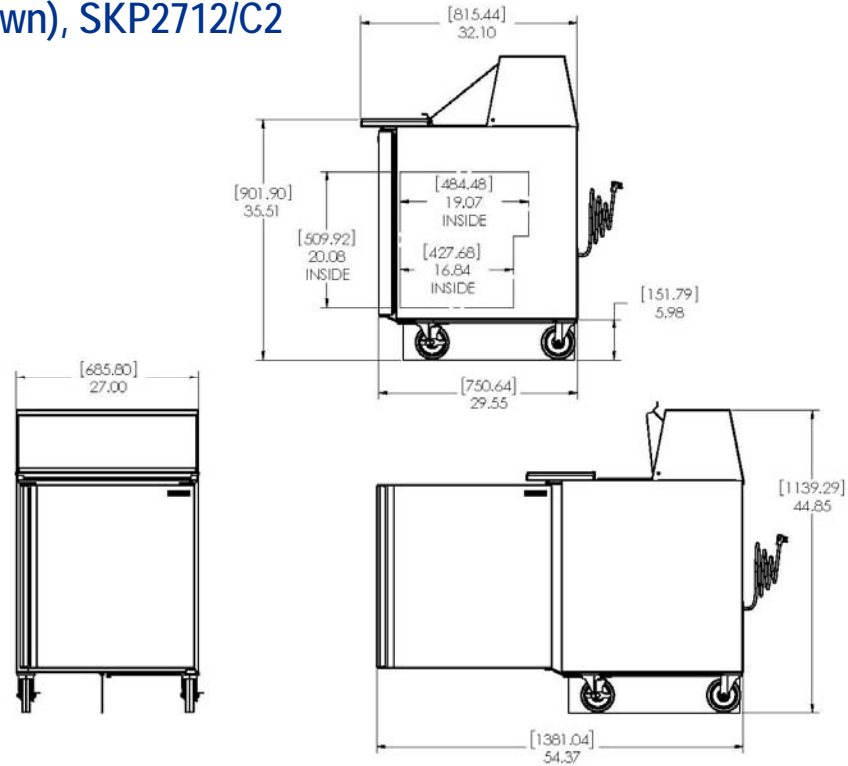

Dimensions

Model Number	Width in (mm)	Height in (mm)	Depth in (mm)	Gross Shipping Weight lb (kg)	Unit Net Weight lb (kg)	Shipping cu ft (cu m)
SKP278/C2 (R134A)	27 (685.80)	44.85 (1139.29)	32.10 (855.95)	210 (95.26)	190 (86.18)	28.06 (.79)
SKP2712/C2 (R134A)	27 (685.80)	44.85 (1139.29)	39.0 (990.57)	235 (106.60)	215 (97.52)	34.44 (.98)

Electrical

Model Number	Country of Origin	Amps	Voltage	Hz	Plug
SKP278/C2	USA	3.9	115 VAC	60 Hz	TYPE 5-15P PLUG
SKP2712/C2	USA	4.9	115 VAC	60 Hz	TYPE 5-15P PLUG

Certifications



Specifications

SKEPT4812-SD-1-BM1

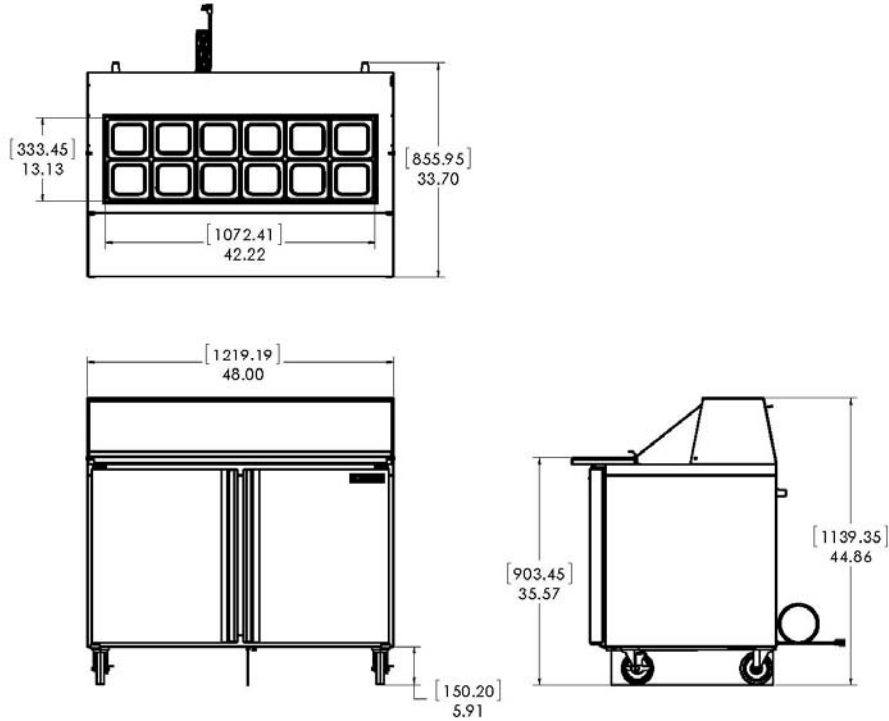

Dimensions

Model Number	Width in (mm)	Height in (mm)	Depth in (mm)	Gross Shipping Weight lb (kg)	Unit Net Weight lb (kg)	Shipping cu ft (cu m)
SKEPT4812-SD-1-BM1 (R290)	48 (1219.19)	44.86 (1139.35)	33.70 (855.95)	330 (149.69)	300 (136.08)	46.93 (1.33)

Electrical

Model Number	Country of Origin	Amps	Voltage	Hz	Plug
SKEPT4812-SD-1-BM1 (R290)	USA	1.8	115 VAC	60 Hz	NEMA 5-15P PLUG

Certifications

