

CU50 Service Parts

This is the illustrated parts list for the CU50 Cube Ice Machines.

When ordering a service part, always refer to the complete model number of the equipment being repaired to be sure of obtaining the correct part. Many times there are slight differences between models, and having the complete model number will aide in selecting the correct part.

The cabinet changed in November 2014 to include a service panel.

In early 2019 the compressor changed along with some of the EEPROM values in the controller represented in the C series: SCCG50MC-1 and SCCP50MC-1

Table of Contents

Door Components	Page 2
Cabinet	Page 3
Reservoir and Spray Pump	Page 4
Refrigeration	Page 5
Under Bin Parts	Page 6
Control System	Page 7
Schematic Diagram	Page 8
Wiring Diagram	Page 9

CU50 Service Parts

Door Components

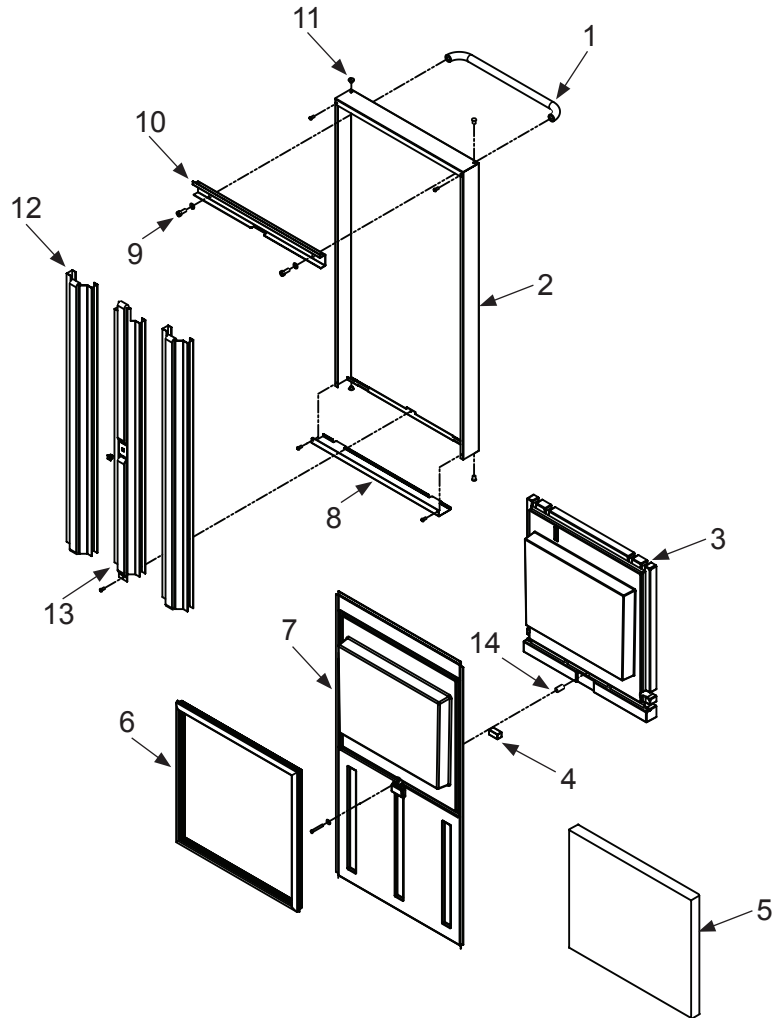

Item Number	Part Number	Description
1	02-3847-01	Handle, door
2	A39678-001	Door panel
3	02-4445-01	Insulation, upper
4	11-0587-01	Magnet, door
5	02-4570-01	Insulation, lower
6	13-0949-03	Door gasket
7	02-4569-01	Liner, door
8	A39676-001	Door bottom
9	03-3814-02	Screw, handle
10	A39675-001	Bracket, door handle
11	03-3927-01	Bushing, door hinge, same on bottom
12	A39677-001	Door support
13	A39677-002	Door support, center
14	03-3926-01	Spacer
15	A39860-021	Complete door, assembled. Includes all above parts

CU50 Service Parts

Cabinet

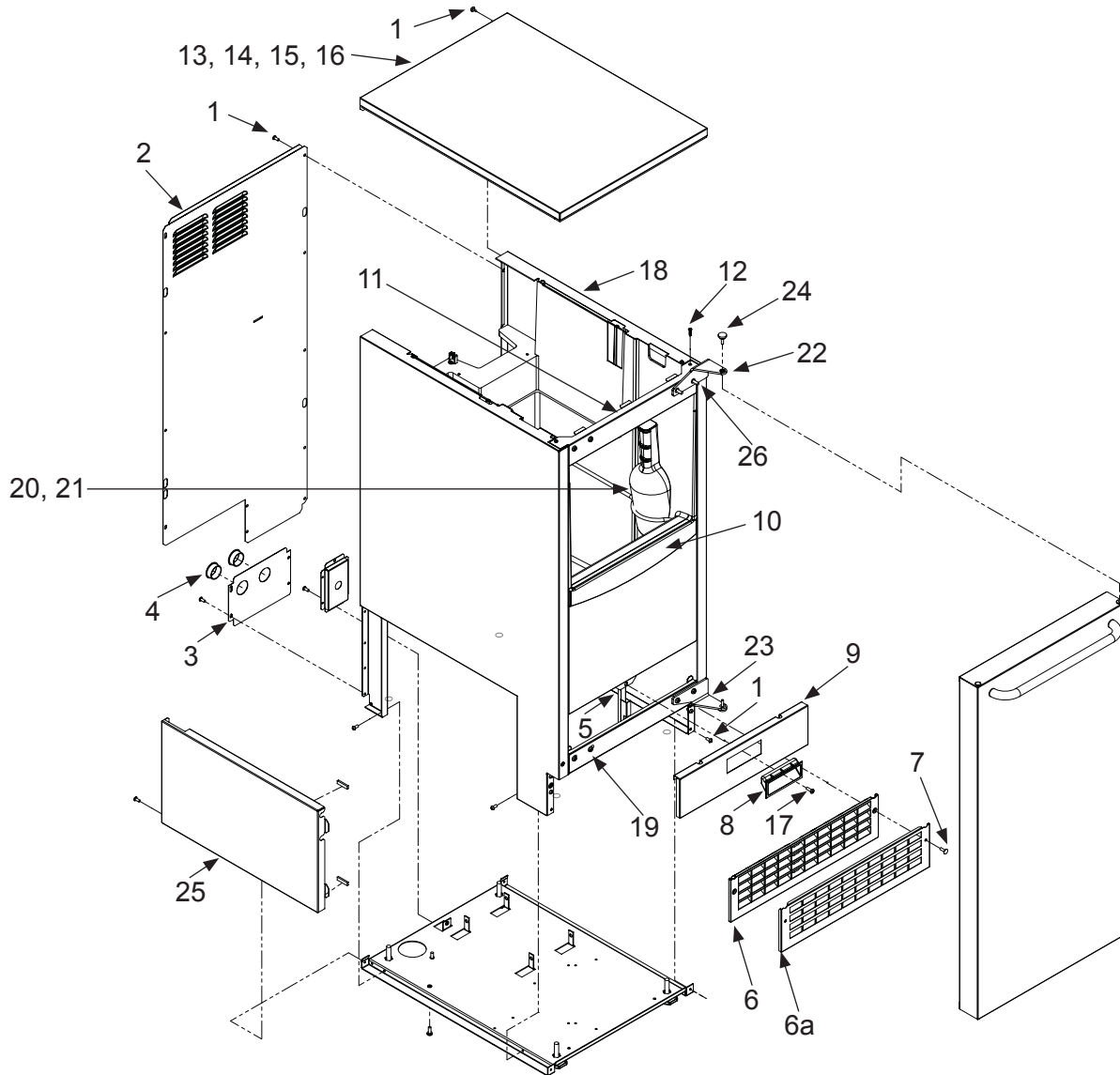

Item Number	Part Number	Description	Item Number	Part Number	Description
1	03-1531-01	Screw	14	02-4438-02	Gasket strip - across
2	A39363-001	Back panel	15	02-4426-01	Insulation pad
3	A39389-001	Utility routing bracket	16	A39362-003	Top panel, SS
4	12-1213-11	Snap bushing	17	03-1403-86	Screw
5	A39392-001	Srv panel mntg bracket	18	A39618-002	SS cabinet & bin
6	02-4390-01	Kickplate	19	A39700-001	Bottom hinge panel, SS
6a	A39469-001	SS kickplate	20	A34816-001	Bin stat bracket/scoop hldr
7	03-1403-86	Screw	21	02-4391-03	Scoop
8	02-4441-01	Panel handle	22	02-4568-02	Hinge
9	A39381-003	Service panel, SS	23	02-4568-01	Hinge
10	02-4392-01	Bin edging	24	03-3834-01	Pin, hinge
11	A39699-001	Top hinge panel, SS	25	A39615-001	Service panel
12	03-3836-03	Screw	26	03-3818-01	Hinge mounting screw
13	02-4438-01	Gasket - for edges			

CU50 Service Parts

Reservoir and Spray Pump

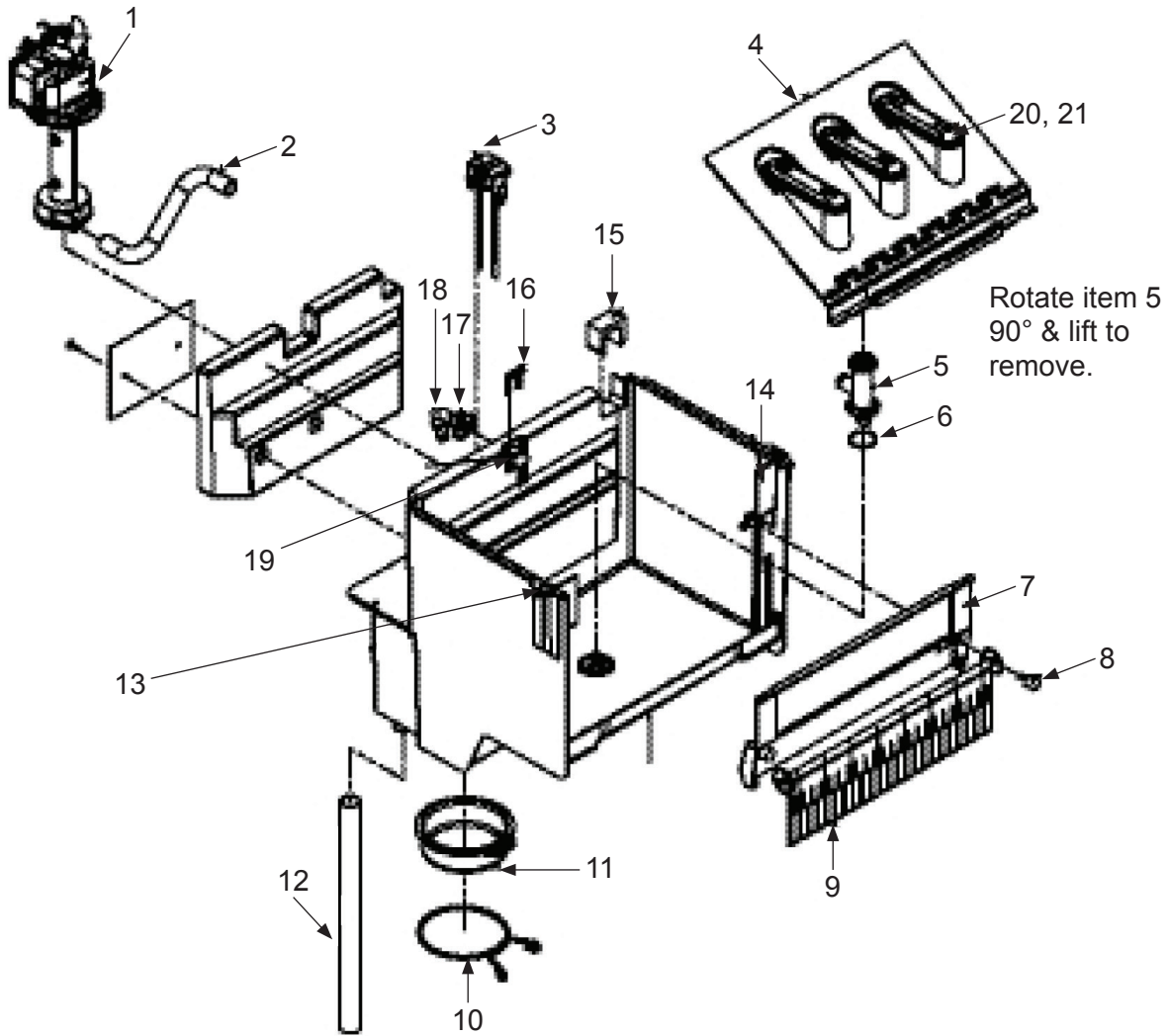

Item Number	Part Number	Description	Item Number	Part Number	Description
1	12-2986-21	Water pump, incl item 1a	15	02-4475-01	Grommet
1a	02-1719-00	Fan blade	16	02-4381-03	Clip
2	02-4379-01	Pump discharge hose	17	13-0617-04	O-ring
3	A39030-023	Water probe	18	02-4381-01	Barbed fitting
4	02-4371-03	Spray platform	19	02-4381-02	Spout
5	02-4368-01	Water Tee	20	02-4373-01	O-ring
6	13-0617-11	O-ring	21	02-4370-21	Spray nozzle, kit. Set of 3 nozzles, o-rings, screws and nuts.
7	02-4365-01	Front bracket			
8	03-3892-01	Thumb screw			
9	A39357-001	Curtain			
10	02-4383-01	Clamp			
11	02-4369-01	Drain cap			
12	02-4428-01	Drain tube			
13	02-4375-01	Evap bracket, left			
14	02-4375-02	Evap bracket, right			

CU50 Service Parts

Refrigeration

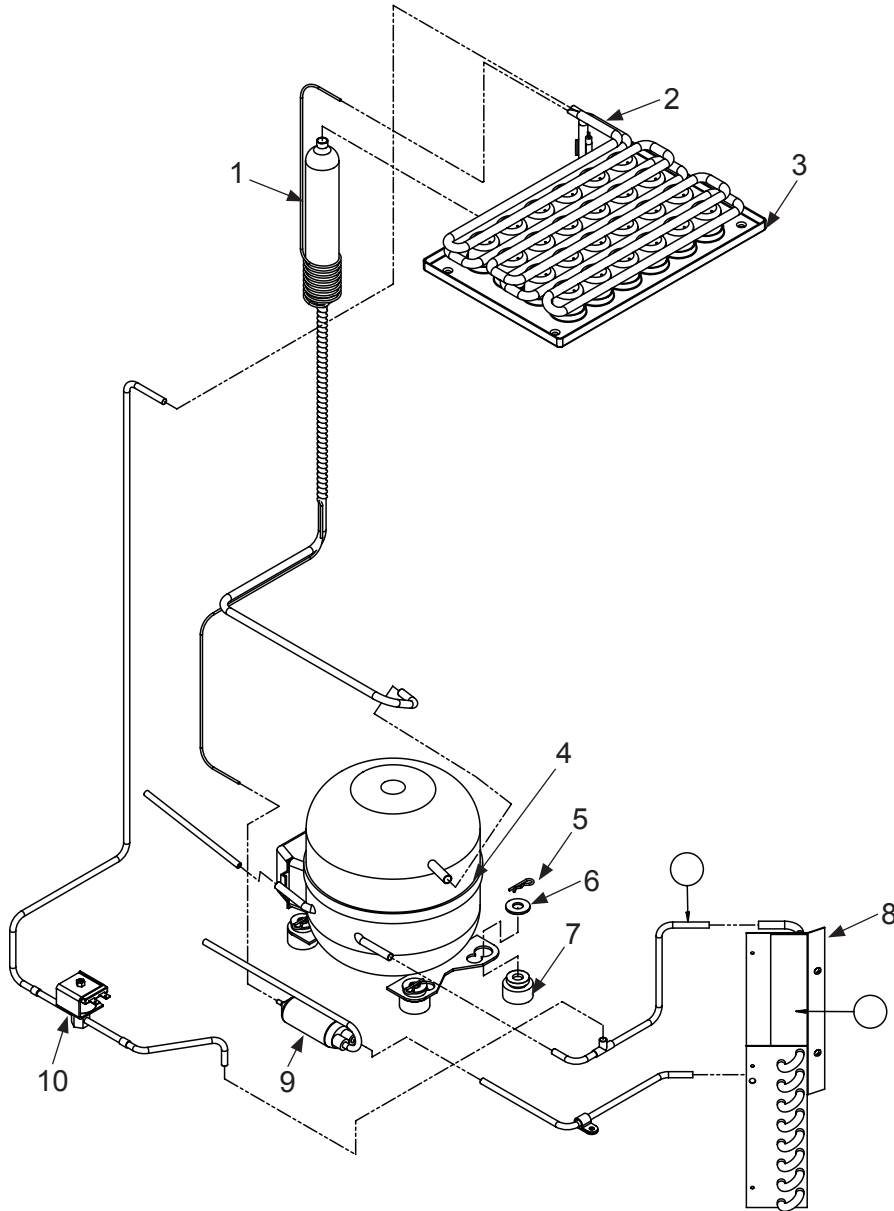

Item Number	Part Number	Description	Item Number	Part Number	Description
1	A39384-001	Suction line accumulator assy	4a	18-8939-51	Overload
2	11-0577-01	Thermistor	4b	18-8939-52	A,B Model Relay
	03-1711-01	Thermistor holder	5	03-3821-01	Clip
3	02-4376-03	Evaporator	6	03-1407-08	Washer
4	18-8939-21	Compressor* A Model Tecumseh TPB0413Y-AA	7	18-4700-28	Grommet
	18-8939-51	A-C Model Overload	8	18-8940-01	Condenser
	18-8939-52	A,B Model Relay	9	02-4416-01	Drier
	18-8994-21	Compressor* C Model Tecumseh AE3425Y-AA1A	10	11-0562-21	Hot gas valve
	18-8994-52	C Model Relay	10a	11-0562-22	HGV coil

Compressor includes overload, relay and drier

CU50 Service Parts

Under Bin Parts

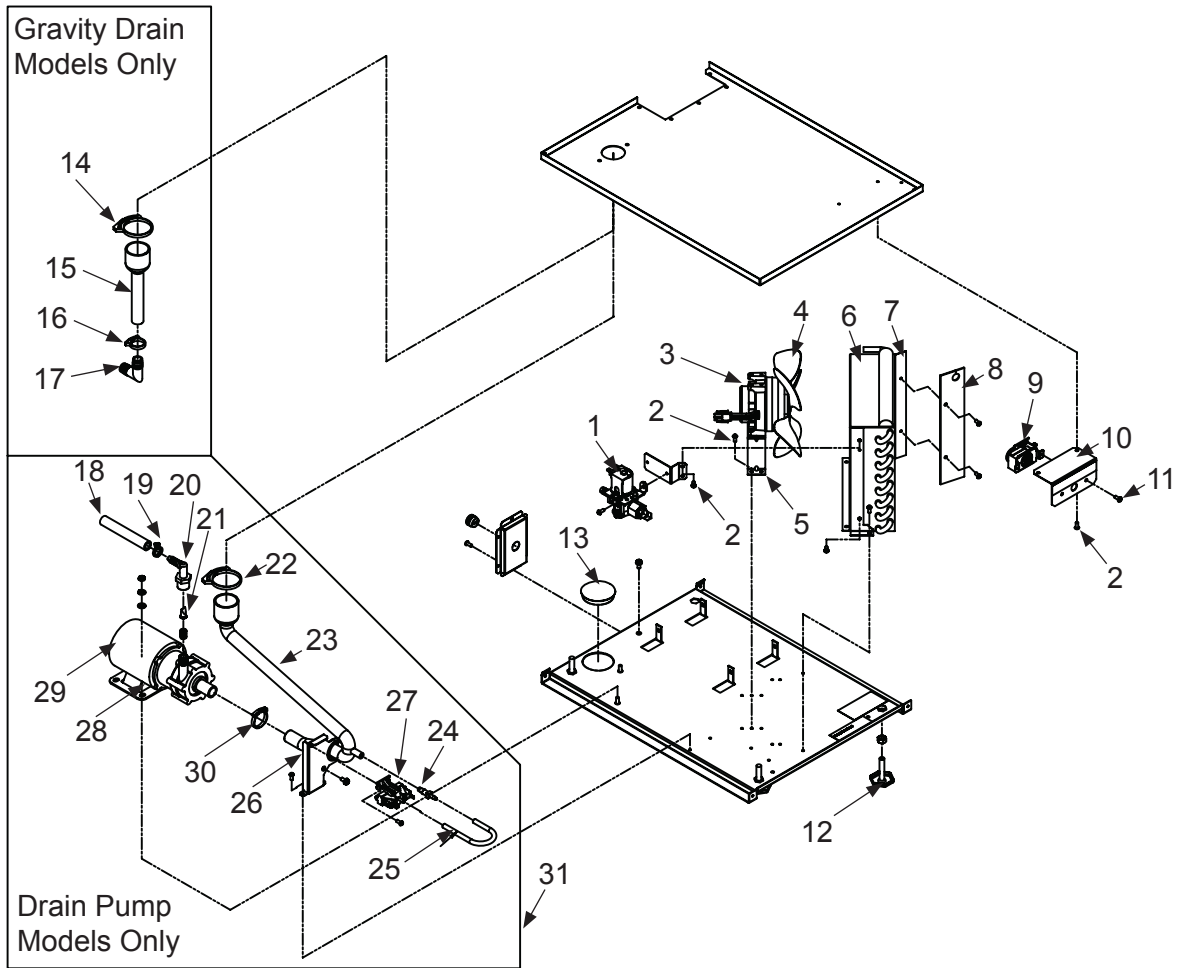

Item Number	Part Number	Description	Item Number	Part Number	Description
1	12-2990-01	Inlet water sol valve	18	A37334-001	Discharge hose
1a	05-0590-01	Full Hose Req. 4ft	19	02-0534-02	Hose clamp
2	03-1531-01	Screw	20	02-3522-01	Elbow
3	12-3024-01	Fan motor	21	02-3374-01	Check valve
4	02-4197-01	Fan blade	22	02-2814-13	Hose clamp
5	A39556-001	Fan motor bracket	23	02-4413-01	Drain tube
6	A39460-001	Fan shroud	24	02-3406-01	Barbed connector
7	13-0909-01	Gasket, order 1 & cut to fit	25	05-0591-01	Switch hose
8	02-4450-01	Air baffle	26	A39370-001	Switch bracket
9	11-0617-21	Thermostat	27	11-0504-01	Pressure switch
10	A39379-001	Thermostat bracket	28	03-3904-01	Spring
11	03-1403-16	Screw	29	12-2503-21	Pump & motor only
12	03-1608-01	Leg leveler	30	02-2814-10	Hose clamp
12a	02-4415-01	Leg cap	31	A39462-021*	Pump kit*
13	02-1875-18	Hole plug	The complete kit shouldn't be use used for warranty purposes without an authorization number given from tech support.		
14	02-2814-13	Hose clamp	<i>Not Shown:</i>		
15	02-4412-01	Drain hose	NS1	12-3001-01	Drain pump harness
16	02-2814-08	Hose clamp			
17	16-0671-01	Elbow			

CU50 Service Parts

Control System

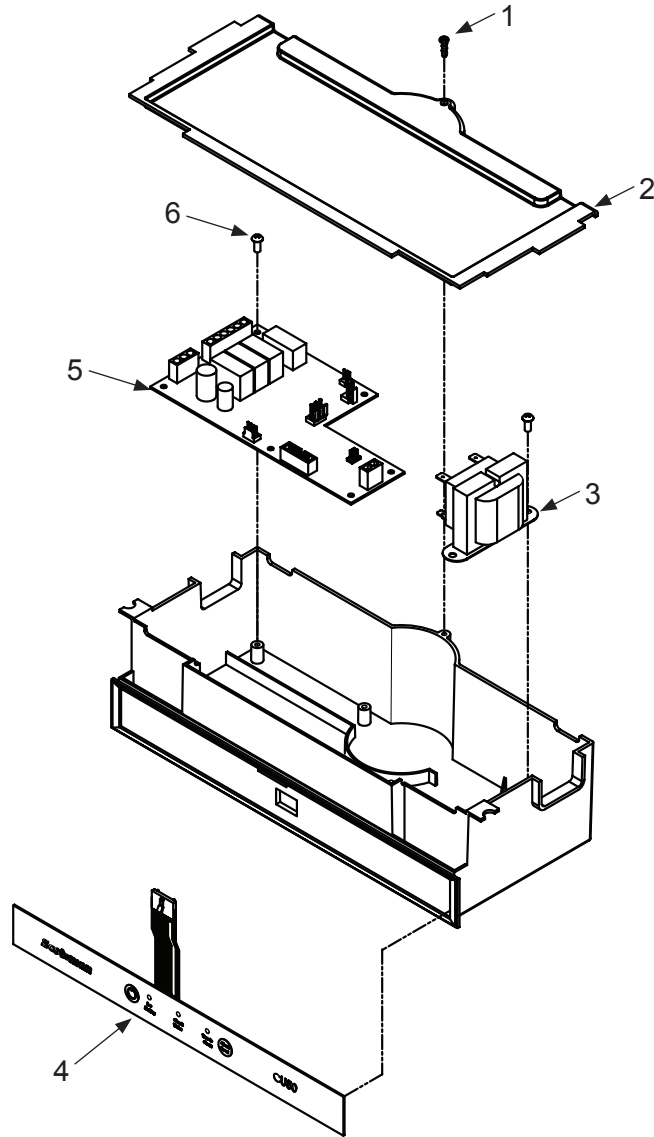

Item Number	Part Number	Description
1	03-3836-03	Screw
2	02-4386-01	Cover
3	12-2924-01	Transformer
4	11-0588-01	Switch panel
	11-0573-25	Controller A,B Model
5	11-0573-52	Controller C Model
6	03-1531-01	Screw

Item Number	Part Number	Description
<i>Not Shown:</i>		
NS1	12-3003-01	Bin stat harness
NS2	12-3000-02	Hi voltage harness, lower
NS3	12-3000-01	Hi voltage harness, upper
Note: If replacing the lower harness, always replace the upper one too.		
NS4	12-2992-01	Water sensor harness
NS5	12-1638-21	Power cord

CU50 Service Parts

Schematic Diagram

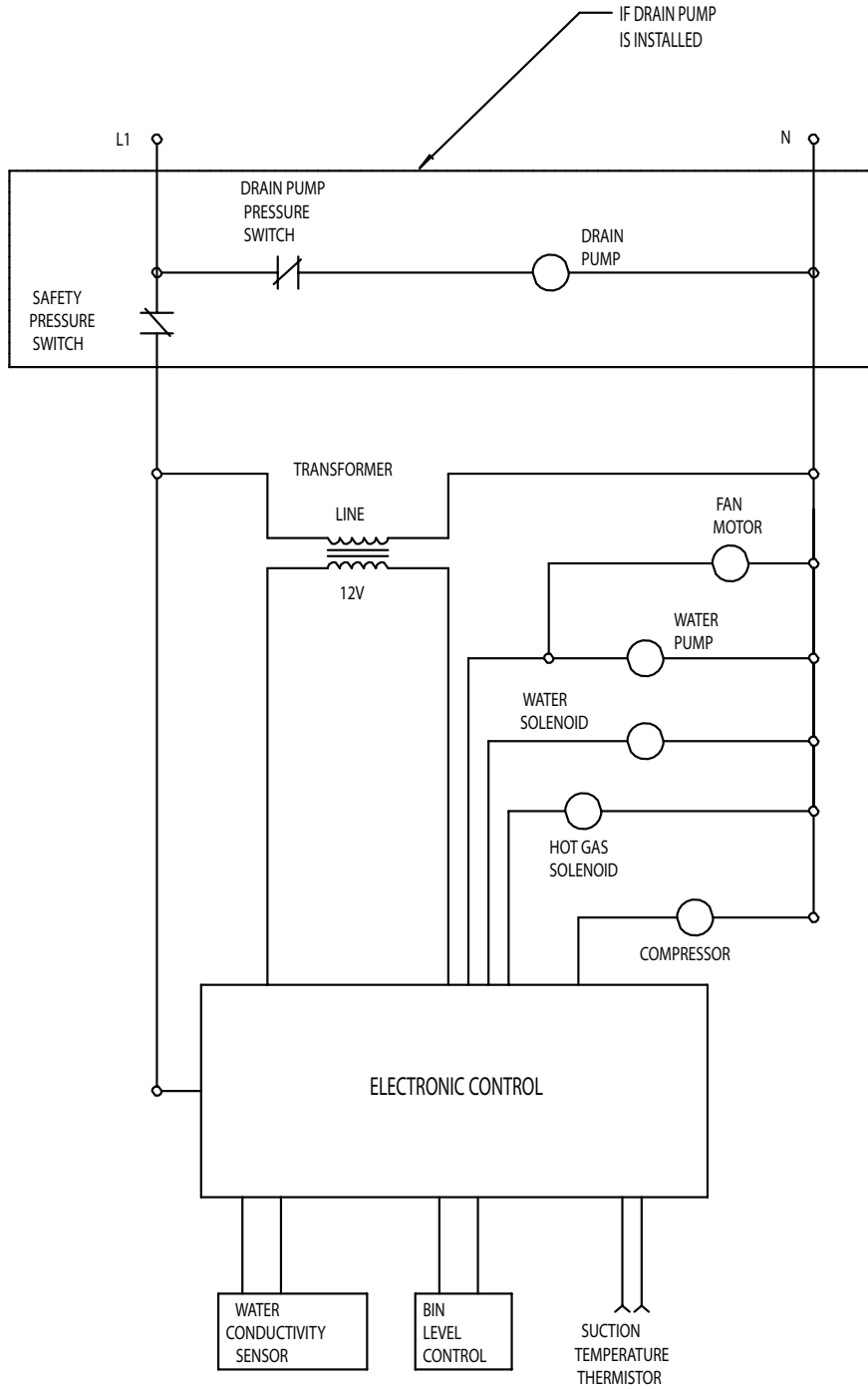

SWITCHES ON THIS UNIT
SHOWN IN FREEZE CYCLE
WITH DRAIN PUMP IN OPERATION
AND BIN DOOR CLOSED

CU50 Service Parts

Wiring Diagram

