



3245 Corridor Drive, Eastvale, CA 91752  
800.769.2414 • 951.360.1600  
951.360.7500 (Fax)

## OWNER’S MANUAL INSTRUCTIONS, INSTALLATION, OPERATION, MAINTENANCE CONVECTION OVEN SERIES, R(D)COS/R(D)COD

All Royal Range of California, Inc. equipment is manufactured for use with the type of gas specified on the rating plate and for installation in accordance with National Fuel Gas Code ANSI Z223.1 (latest edition)

**FOR YOUR SAFETY**  
**Do not store or use gasoline or other flammable vapors or liquids in the vicinity of this or any other appliance.**

**WARNING:** Improper installation, adjustment, alteration, service or maintenance can cause property damage, injury or death. Read the installation, operating and maintenance instructions thoroughly before installing or servicing this equipment.

“Instructions to be followed in the event the user smells gas” shall be posted in a prominent location in the kitchen area. This information shall be obtained by consulting the local gas supplier.

**RETAIN THIS MANUAL FOR FUTURE REFERENCE.**

### **IMPORTANT**

Safe and satisfactory operation of your equipment depends to a great extent on its proper installation. Installation must conform with local codes, or in the absence of local codes, to the National **Fuel Gas Code, ANSI Z-223.1** (latest edition.). In Canada, installation should conform to installation codes for gas burning appliances and equipment standard **CAN1-B149.1** (Natural. gas) or **CAN1-B149.2** (Propane gas).

Electrical wiring from the Electric Meter, main control box or service outlet to appliance must be electrically grounded in accordance with local codes or in the absence of local codes, with the **National Electrical Codes ANSI/NFPA 70** – current. In Canada, conform to Canadian **Electrical Code CSA-C22.1**

### **Installation, Operation and Service Personnel:**

Qualified, certified, licensed and / or authorized personnel who are familiar with and experienced in state/local installation codes should perform installation of the equipment. Adequate clearance for servicing and proper operation should be provided.

Qualified or authorized personnel who have read this manual and are familiar with the functions of the equipment should perform operation of the equipment.

Qualified personnel who are knowledgeable with Royal Range Cooking Equipments should perform Service of the equipment.

### **GENERAL: RATING PLATE**

The rating plate is located in front of the oven below the oven section. Information on this plate includes the model, and serial number, BTU / hour input of the burners, operating gas pressure in inches WC, and whether the appliance is orificed for Natural or Propane gas. Pilot lighting instructions are also located in the same area. **ROYAL RANGE COOKING APPLIANCES MUST BE CONNECTED ONLY TO THE TYPE OF GAS IDENTIFIED ON THE RATING PLATE!**

**CLEARANCES:** The appliance area must be kept free and clear of all combustibles. This unit is design-certified for the following installations only:

The clearances from combustible and noncombustible construction are as follows:

	<b>Combustible</b>	<b>Noncombustible</b>
<b>Back</b>	6”	0
<b>Side</b>	6”	0

**DO NOT MOUNT** oven on a curb base. Use legs/casters provided. Adequate air space at the bottom and rear of the unit must be provided for proper venting of blower motor.

**ASSEMBLY:** DO NOT USE door to lift or move oven!!! All ovens must be installed on leg assembly or casters shipped with the unit. The leg/stand assembly parts or casters are shipped separately.

### **SINGLE OVEN:**

Assemble the leg/stand assembly as follows:

1. Remove legs from package.
2. Line leg plate holes with holes at the bottom of the base and secure with (4) 3/8-16 bolts. After 4 legs are assembled, bolt the 4 channels by lining with the holes on the leg.

Figure 1

## PAN RACK ASSEMBLY INSTRUCTIONS

TOOLS NEEDED: 7/16 & 9/16 SOCKET SET OR WRENCH

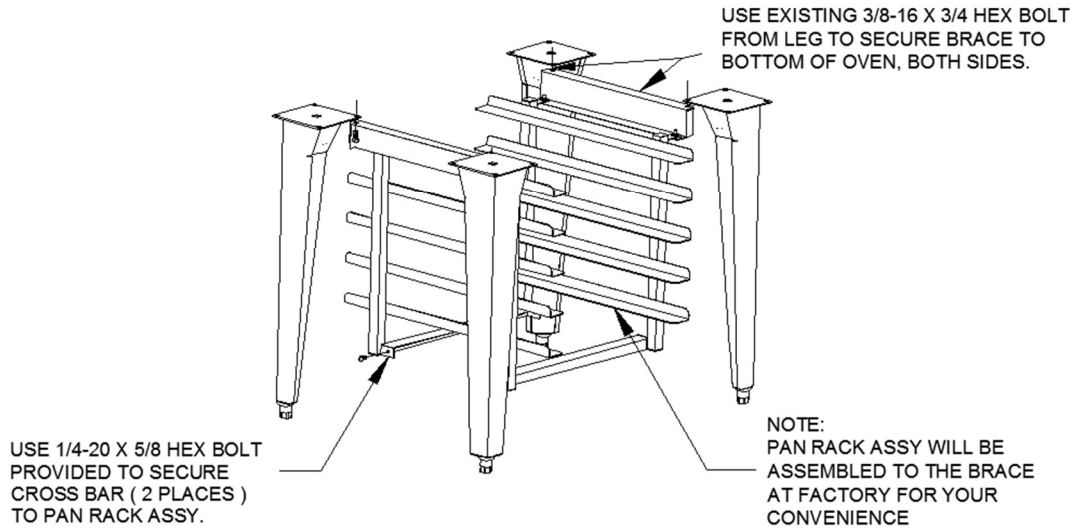

### **DOUBLE DOVEN:** (6" leg assembly is provided) Single units stacked.

1. Match holes of the leg plate with oven bottom base and assemble with bolts (3/8"-16) provided. **Note: Welded nut on the leg plate should be inserted through the hole up into the unit.**
2. Screw studded leg into the leg plate.
3. Set top oven on top of bottom oven.
4. Secure units to each other at rear as shown in figure 2.
5. For units that are already stacked, please follow steps 1 and 2.

Figure 2

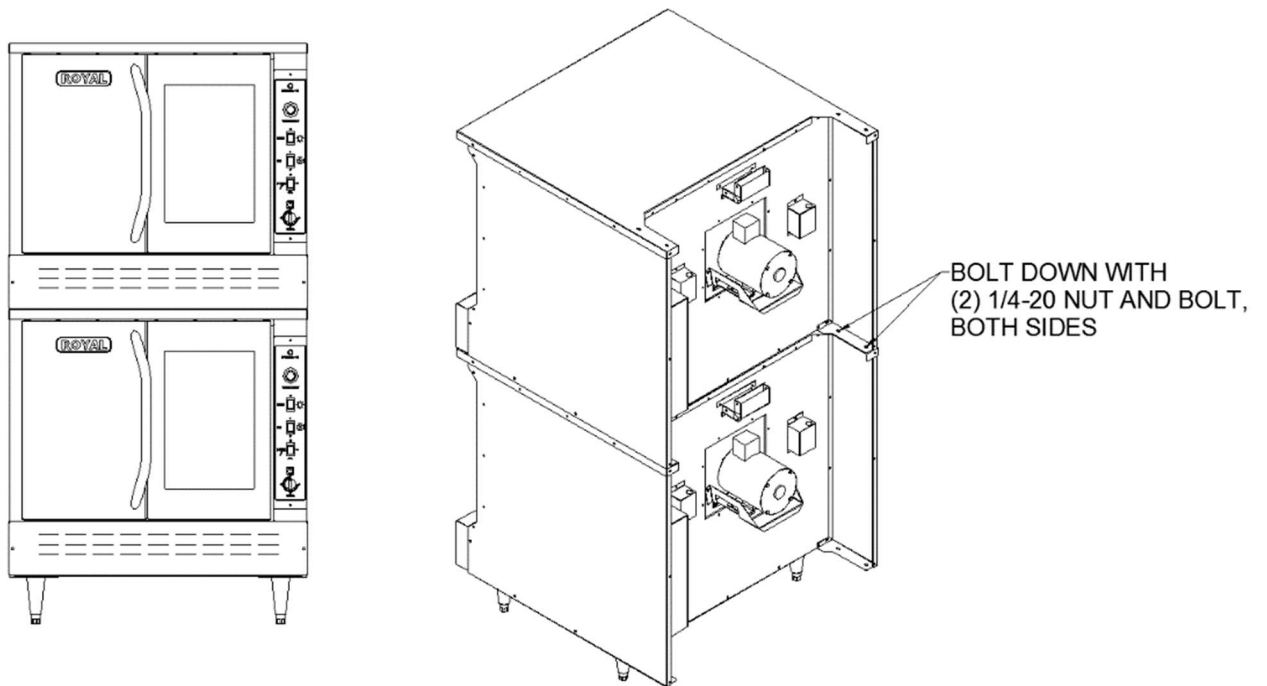

**CASTER INSTALLATION:** If casters are provided, match holes on the caster with holes on the oven bottom base and fasten with bolts provided. NOTE: Front casters are locking type.

**LEVELING:** A carpenter's spirit level should be placed on the oven's center baking rack and the unit leveled both front-to-back and side-to-side. If it is not level, cakes, casseroles, and any other liquid or semi-liquid batter will not bake evenly, burner combustion may be erratic, and the unit will not function efficiently.

If the floor is relatively smooth and level, the unit may be further leveled with adjustment in the foot of the leg. Units with casters must be leveled with shims. A unit will probably not return to the same position after being moved, requiring re-leveling after each and every move.

**AIR SUPPLY & VENTILATION:** The area in front of, around and above the appliance must be kept clear to avoid any obstruction of the flow of combustion and ventilation air. Adequate clearance must be maintained at all times in front and at the sides of the appliances for Servicing and proper operation.

Means must be provided for any commercial, heavy-duty cooking appliance to exhaust combustion waste products to the outside of the building. Usual practice is to place the unit under an exhaust hood. Filters and drip troughs should be part of any industrial hood. Consult local codes before constructing and installing a hood.

Strong exhaust fans in this hood or in the overall air conditioning system can produce a slight vacuum in the room and/or cause air drafts, either of which can interfere with pilot or burner performance and can also be hard to diagnose. Air movement should be checked during installation; if pilot or burner outage problems persist, make-up air openings or baffles may have to be provided in the room.

### **ELECTRICAL CONNECTION:**

ROYAL RANGE CONVECTION OVEN requires a 120 volt supply to operate the ignition system and blower. The supply cord provided along with the appliance is equipped with a three prong (grounding) plug for protection against shock hazard. The electrical service in the building must be equipped with a properly grounded three prong receptacle, in accordance with local codes, or in the absence of local codes, with the national electrical code, ANSI/NFPA 70-1987, in Canada, conform to Canadian electrical codes, CSA-C22.1.

**Do not cut or remove the grounding prong from this plug.** Wiring diagram is located on the backside of the appliance.

**Disconnect power supply before cleaning or servicing.**

**NOTE:** This appliance is not capable of being operated in the event of power failure. No attempt should be made to operate this appliance during power failure.

**GAS CONNECTION:** \*Single Deck oven requires one gas connection, \*\*Double Deck oven requires two gas connections.

The gas supply (service) line must be the same size or greater than the inlet line of appliance. Royal Range ovens use a 3/4" NPT inlet. Sealant on all pipe joints must be resistive to LP gas.

**MANUAL SHUT-OFF VALVE:** This installer-supplied valve must be installed in the gas service line ahead of the appliance and regulator in the gas stream and in a position accessible in the event of an emergency.

**PRESSURE REGULATOR:** All commercial cooking equipment must have a pressure regulator on the incoming service line for safe and efficient operation, since service pressure may fluctuate with local demand. The pressure regulator comes with the oven.

#### **Failure to install the pressure regulator will void the equipment warranty!**

The regulators supplied with Royal Range Ovens, have 3/4" inlet /outlet ports and are adjusted at the factory for 5" WC (Natural gas) or 10" WC (Propane gas) depending on customer's ordering instructions.

Prior to connecting the regulator, check the incoming line pressure, as these regulators can only withstand a maximum pressure of 1/2 PSI (14"WC). If the line pressure is beyond this limit, a step-down regulator will be required. The arrow shown on the bottom of the regulator body shows gas flow direction; it should point downstream to the appliance. The red air vent cap on the top regulator is part of the regulator and should not be removed.

Any adjustments to regulators must be made **only** by qualified service personnel with the proper equipment.

**CONNECTIONS:** Please check installer-supplied intake pipes visually and /or blow them out with compressed air to clear any dirt particles, threading chips, or other foreign matter before installing a service line. When gas pressure is applied these particles can clog orifices. All connections must be sealed with a joint compound suitable for LP gas, and all connections must be tested with a soapy water solution before lighting any pilots!

### **FLEXIBLE COUPLING, CONNECTORS AND CASTERS:**

If the unit is to be installed with flexible couplings and /or quick-disconnect fittings, the installer must use an AGA design-certified commercial flexible connector of at least 3/4" NPT (with suitable strain relief). The flexible connector must comply with the standard for **Connectors for Movable Gas Appliances, ANSI Z21.69** and addendum **Z21.69a** (or latest edition) and a quick-disconnect device that complies with the standard for quick-disconnect devices for use with Gas Fuel should comply with **ANSI Z21.41** and addendum **Z21.41a** (or latest edition). If disconnection of the restraint is necessary, make sure to reconnect restraint after the appliance has been returned to its originally installed position. Domestic gas or water connectors are not suitable!\*Restraining device may be attached to the back frame/panel of unit.

If the unit is to be installed with casters, a flexible connector must be used and the same ANSI standard apply. Locking front casters are provided to limit the movement of the appliance without depending on the connector or associated piping. A suitable strain relief must be installed with the flexible connector.

All connections must be sealed with a joint compound suitable for LP gas and all connections must be tested with a soapy water solution before lighting pilots.

## **LIGHTING:**

### **CAUTION: When lighting pilots and checking for leaks, do not Stand with your face close to the combustion chamber.**

All Royal Range appliances are adjusted and tested before leaving the factory, effectively matching them to sea level conditions. Adjustments and calibrations to assure proper operation may be necessary on installation to meet local conditions, low gas characteristics, to correct possible problems caused by rough handling or vibration during shipment, and are to be performed only by qualified service personnel. These adjustments are the responsibility of the customer and/or dealer and are not covered by our warranty. Check all gas connections for leaks with a soapy water solution before lighting any pilots.

### **DO NOT USE AN OPEN FLAME TO CHECK FOR LEAKS!**

Putting an open flame beside a new gas connection is extremely dangerous.

- A. Turn the thermostat dial to the "OFF" position. Place the power switch to the "OFF" position.
- B. Wait five minutes.
- C. Place power switch to the "ON" position. Turn the oven thermostat to the desired temperature.
- D. For a complete shutdown, place the thermostat and power switch in the "OFF" position.

## **TO CHECK FOR GAS LEAKS**

- (1) Remove the kick plate and the component cover at the rear of the oven
- (2) Check pilot tubing and burner tubing for leaks at the connectors with a soapy water solution.
- (3) Light the pilot as described above.
- (4) Turn the thermostat to any setting and the burner should light.
- (5) Check the burner orifice elbow connection downstream of the valve with a soapy water solution.
- (6) Check the burner visually for blue flame. There should be no yellow tips or soot. If yellow tipping occurs, call an authorized service person to adjust the burner air shutter.

**FINAL PREPARATION:** On initial installation, turn the oven to 250 degrees and operate for about 1 hour, then reset the thermostat to its maximum and operate for another hour. This will drive off solvents remaining in the unit. At the end of this second hour, turn the thermostat OFF, open the door and set the switch to 'cool'. Oven should then be thoroughly washed using hot, soapy water before being used.

**CLEANING AND MAINTENANCE:** Any piece of equipment works better and lasts longer when maintained properly.

Cooking equipment is no exception. Your Royal Range oven must be kept clean during the working day and thoroughly cleaned at the end of the day.

**CAUTION:** Never use Ammonia in an Oven that is warmer than room temperature and always have direct ventilation.

## **DAILY CLEANING: OVENS**

1. Remove the baking racks. Wash in hot soapy water, and replace after the rest of the oven is cleaned.
2. Scrape off any food particles with a nylon griddle scraper. Be very careful about scratching the porcelain finish on the oven liner panels.
3. Wash all the above with hot soapy water, then reassemble.
4. Baked on spills may be loosened and stubborn stains removed with ordinary household ammonia and scrubbing with a nylon pad in a cold oven only.
5. Do not allow spray type oven cleaners to come into contact with the temperature probe in the oven.
6. After cleaning the oven, rinse well with ¼ cup of vinegar to one quart of clear water solution to neutralize any caustic residue of the cleaning compound. Wipe dry.
7. To increase the life of the motor, follow these instructions:
  - (a) Never run oven with motor off.
  - (b) After you finish cooking and the oven is not to be used for more than ½ hour. Place the switch to the "COOL" position and open the door. When oven temperature is equal to room temperature turn unit off.

## **PERIODIC CLEANING:**

Check the ventilation system periodically to see that nothing has fallen down into the exhaust vents. Lubricate the pivot pins of the oven door hinge. Use a multi-purpose lubricating oil sparingly so **as to not drip oil needlessly.**

Your appliance should be checked for safe and efficient operation at least once a year by qualified service personnel.

## **STAINLESS STEEL:**

All stainless steel body parts should be wiped regularly with hot soapy water during the day and with a liquid cleaner designed for this material at the end of each day.

**DO NOT USE** steel wool, abrasive cloths, cleaners or powders to clean stainless surfaces! If it is necessary to scrape stainless steel to remove encrusted materials, soak in hot water to loosen the material, then use a wood or nylon scraper.

**DO NOT USE** a metal knife, spatula, or any other metal tool to scrape stainless steel. Scratches are almost impossible to remove.

Contact the factory, the factory representative or a local service company to perform all Maintenance and repairs.