

MILLENNIUM

975.5MLG/MSG + i (L Deluxe / S Standard / i Stainless Steel)

DESIGN

The MILLENIUM range of attractive ergonomically-designed rotisseries, boasts a number of innovative features for increased functionality and are an ideal show-piece used throughout the world in hotels, restaurants and deli stores.

The naked flame from Rotisol's patented burners lick the cast iron hearth creating a spectacular visual, whilst being safe and simple to operate and easy to clean. Spits are driven by individual motors rotating at 2 ½ times per minute allowing meat or poultry to constantly baste itself, sealing in natural juices and cooking to perfection.

FEATURES

- Energy Efficient
- Independent motors
- 2 tempered glass doors
- Safety with installed thermocouple
- Equipped with bottom drip tray with drainage tap
- Powerful halogen lamp.

FINISHES

Standard model in black enamel. A choice of other colours are available. Choses a colour scheme for Millenium.



With chrome or brass trims.

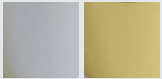









975.5MLG Deluxe

Black and brass finish



ACCESSORIES

A variety of accessories are available for the unit. Video of available [accessories](#) and video of [vertical spit system](#).

CUI975 Anti-cutting prongless spit.		BP975 Chicken spit.		BRC975 Basket spit.	
BS975 Sabre spit for ham / turkey.		BRRO975 Roast-clamp spit.		BA975 Lamb/suckling- pig spit. On demand.	
GCP975 Spare rib rack.		GSV975 Raised rack for meat storage.		PID975 Stainless steel tray to unspit.	

Front view
Rotisserie with roof (optional)
and base on casters (optional)

Side view
Rotisserie with roof (optional)
and base on casters (optional)

Top view
Rotisserie with roof (optional)
and base on casters (optional)

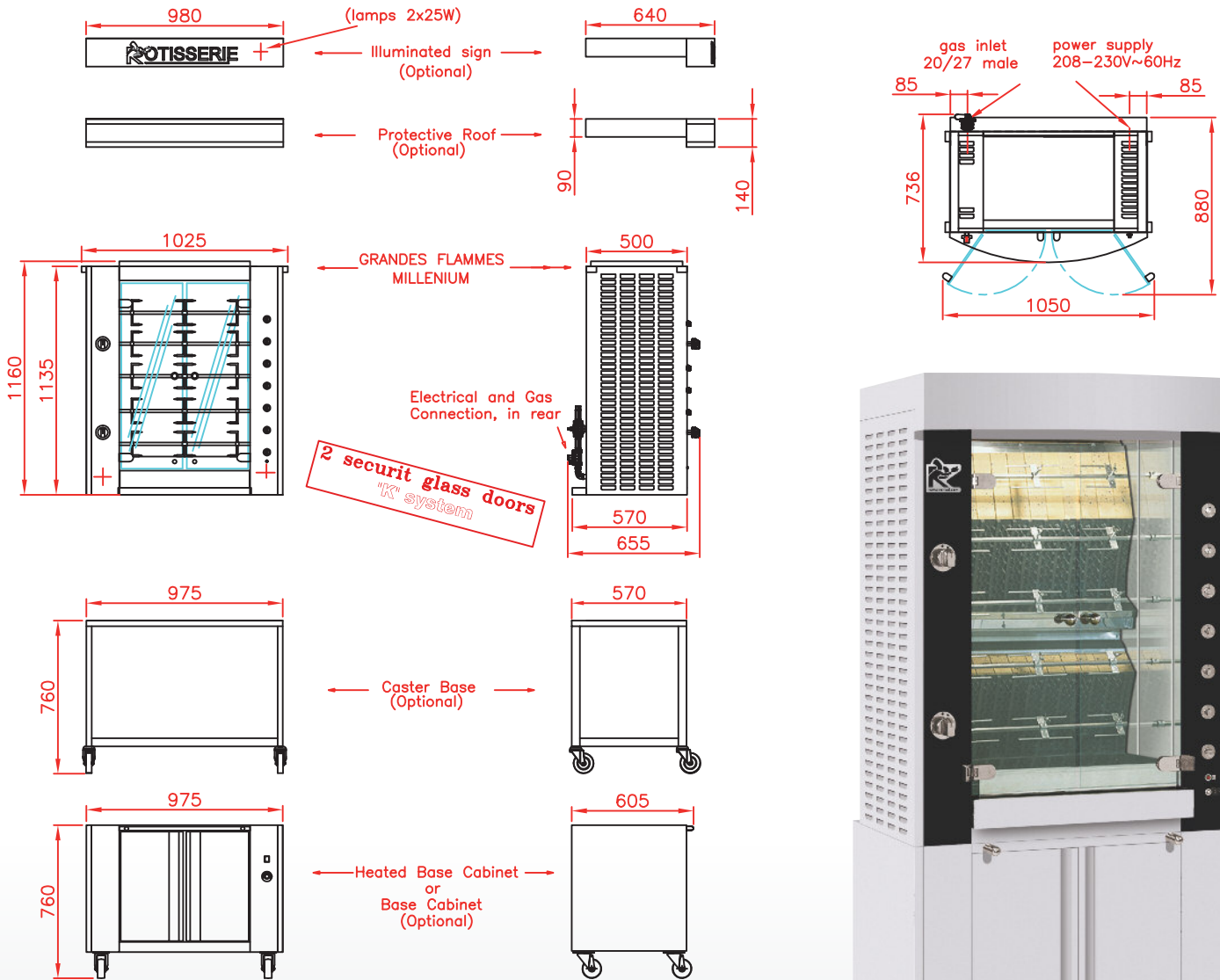

975.5MSG
Standard Finish



Revised : February 2017

SPECIFICATIONS

Gas Power	Natural : 55000 BTU/h ; Propane : 50000 BTU/h.
Gas minimum pressure	Natural : 17,4 mbar. Propane : 27,4 mbar.
Gas connector	¾" male
Electricity	208-230 Volts 1 phase + neutral + earth
Capacity	10/15 poultries
Warranty	1 year parts and labor
Venting	Hood installed conformly with all local codes
Minimum clearance	2½" on the right, left and rear side
Shipping weight	140 kg

CANADA DISTRIBUTOR

Rotisol S.A.S.

Zone industrielle La Trentaine, Avenue Gustave Eiffel
77507 Chelles cedex - FRANCE
bennell@rotisol.com - Tel : +33 1 64 21 80 00
www.rotisol.com

Celco Inc.

www.celco.ca

585 Secretariat Court, Mississauga, Ontario, L5S 2A5
(905) 364-5200 1-866-77CELCO (23526) info@celco.ca