



Intertek  
4001164

Intertek  
4001164



### Safe Blade Removal (SBR) Feature

The Safe Blade Removal (SBR) allows for easy, secure and safe removal of the blade without direct contact with the blade. This feature is designed to simplify blade handling and cleaning while minimizing risk to the operator and reduces risk of injury during cleaning and maintenance.



Model	Blade	Cutting cross section	Food chute	Chute stroke	Footprint	Overall dimensions	Net weight	Power
	in mm	in mm	in mm	in mm	in/mm	in/mm	Lbs Kgs	Hp
STA14	14 350	0.78 20	11.81x11.81 300x300	13 330	A 22.63/575 B 15.35/390 H 23.42/595	A 28.34/720 B 28.54/725 H 23.42/595	99.2 45	1/2

Cord & Plug: Attached 5.5 foot flexible 3-wire cord with molded plug fits a grounded receptacle. NEMA 5-15. Voltage: 115 - 60 - 1

GRAVITY

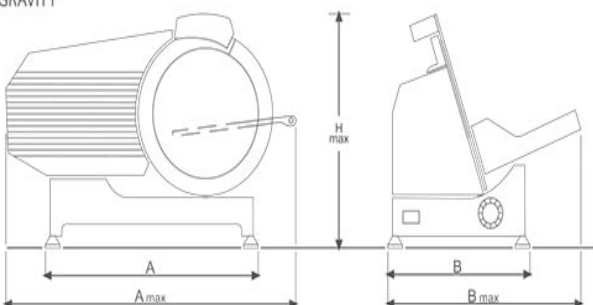

# STA14

PROFESSIONAL GRAVITY SLICER – AUTOMATIC BELT DRIVEN



Intertek  
4001164

Intertek  
4001164

STA14 is a powerful automatic slicer that can also be used manually. Sturdy and high performing: carriage speed selection from 0 up to 60 slices/min. Easy to use, easy to clean. Ideal for supermarkets, restaurants, catering companies, laboratories.

- Anodized aluminium casting construction.
- 14" high quality hardened chromium steel alloy blade.
- Powerful and noiseless continuous use motor.
- Overload protection manual reset.
- 0 to 1/2" slice thickness.
- Multygrip belt drive: always the right grip.
- Special product holder with adjustable fence and three-position heavy food pusher.
- Large clearance between the back of the blade and the base provides access for easy cleaning.
- Slice thickness precision adjustment: gasket-sealed mechanism.
- Drip deflecting edge of the gauge plate: adjustment mechanism is protected.
- No-drip edge base: easy cleaning.
- Stainless steel ball-bearing blade pulley and special moisture-proof gasket.
- Built-in sharpener, removable for cleaning purposes: simple and convenient.
- 30° carriage angle: good visibility of the slice exit area and better ergonomoy.
- SBR (Safe Blade Removal tool)

Large clearance between blade and base. High protection against moisture.

Powerful and noiseless motor.

Wide slice exit area.

Adjustable fence and three-position heavy food pusher.

Sturdy construction for precise slices.

Thickness adjustment: gasket-sealed mechanism.

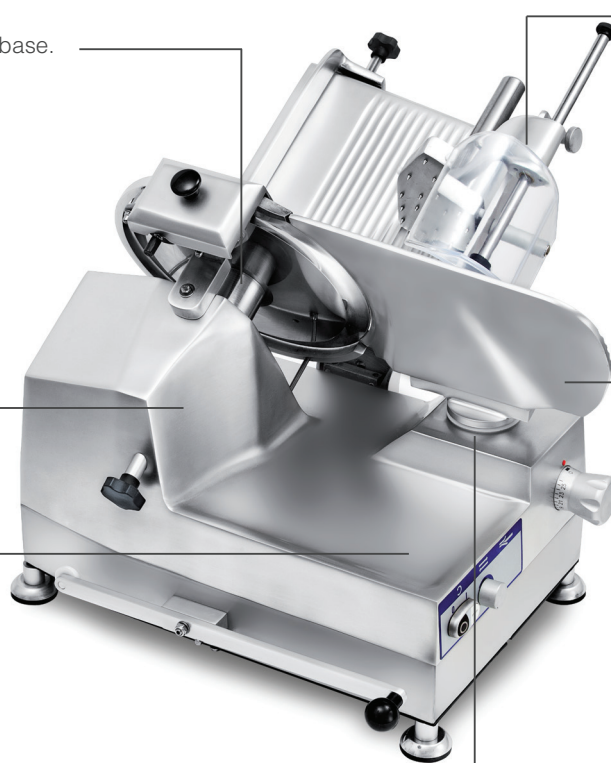

Proudly  
Made in Italy