

OPERATOR MANUAL

IMPORTANT INFORMATION, KEEP FOR OPERATOR

This manual provides information on installation, operating, maintenance, trouble shooting & replacement parts for:

SIDE MOUNT PREP REFRIGERATOR SERIES: 9200-513 9000K-513



THIS MANUAL MUST BE RETAINED FOR FUTURE REFERENCE. READ, UNDERSTAND AND FOLLOW THE INSTRUCTIONS AND WARNINGS CONTAINED IN THIS MANUAL.

WARNING / FOR YOUR SAFETY

Do not store or use gasoline or other flammable vapors and liquids in the vicinity of this or any other appliance.

WARNING

Improper installation, adjustment, alteration, service or maintenance can cause property damage, injury or death. Read the installation, operating and maintenance instructions thoroughly before installing or servicing this equipment.

NOTIFY CARRIER OF DAMAGE AT ONCE

It is the responsibility of the consignee to inspect the container upon receipt of same and to determine the possibility of any damage, including concealed damage. Unified Brands suggests that if you are suspicious of damage to make a notation on the delivery receipt. It will be the responsibility of the consignee to file a claim with the carrier. We recommend that you do so at once.

Manufacture Service/Questions 888-994-7636.

Information contained in this document is known to be current and accurate at the time of printing/creation. Unified Brands recommends referencing our product line websites, unifiedbrands.net, for the most updated product information and specifications.

PART NUMBER PP MNL1709, REV A (03/18)

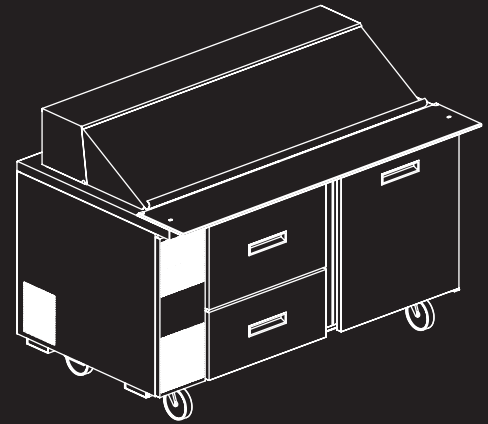

A DOVER COMPANY

1055 Mendell Davis Drive
Jackson, MS 39272
888-994-7636, fax 888-864-7636
unifiedbrands.net

Table of Contents

Important Operator Notices	page 3
Equipment Description	page 4
Installation	page 5
Operation	page 6
Maintenance	page 7
Troubleshooting	page 8-10
Parts List	page 11-14
Electrical Schematic	page 15
Service Log	page 16
Warranty Policies	page 17-19

IMPORTANT - READ FIRST - IMPORTANT

Congratulations on your recent purchase of Unified Brands food service equipment, and welcome to the growing family of satisfied Unified Brands customers.

Our reputation for superior products is the result of consistent quality craftsmanship. From the earliest stages of product design to successive steps in fabrication and assembly, rigid standards of excellence are maintained by our staff of designers, engineers, and skilled employees.

Only the finest heavy-duty materials and parts are used in the production of Unified Brands brand equipment. This means that each unit, given proper maintenance will provide years of trouble free service to its owner.

In addition, all Unified Brands food service equipment is backed by some of the best warranties in the food service industry and by our professional staff of service technicians.

Retain this manual for future reference.

NOTICE: DUE TO A CONTINUOUS PROGRAM OF PRODUCT IMPROVEMENT, UNIFIED BRANDS RESERVES THE RIGHT TO MAKE CHANGES IN DESIGN AND SPECIFICATIONS WITHOUT PRIOR NOTICE.

NOTICE: PLEASE READ THE ENTIRE MANUAL CAREFULLY BEFORE INSTALLATION. IF CERTAIN RECOMMENDED PROCEDURES ARE NOT FOLLOWED, WARRANTY CLAIMS WILL BE DENIED.

MODEL NUMBER _____

SERIAL NUMBER _____

INSTALLATION DATE _____

THE SERIAL NUMBER IS LOCATED IN THE CABINET LEFT SIDE OR BACK WALL CLOSEST TO THE COMPRESSOR COMPARTMENT UNDER THE DRAWER TRACK. AN EXAMPLE IS SHOWN BELOW.

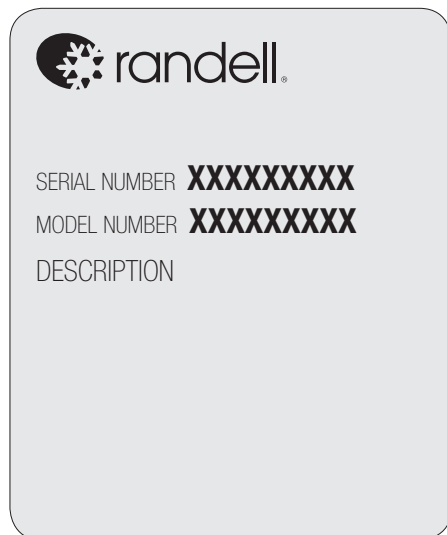

Equipment Description

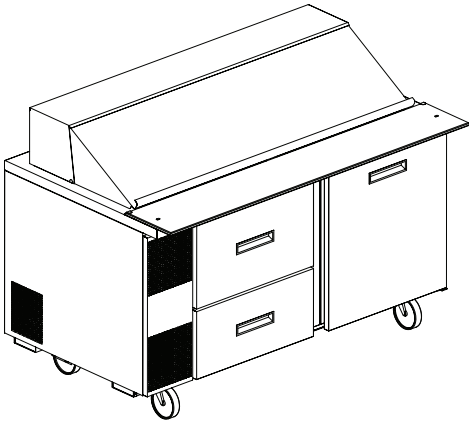

MODEL	LENGTH	DEPTH	HEIGHT	NO. OF DOORS	STORAGE (CUBIC FEET)	PAN CAPACITY	HP	VOLT	AMPS	NEMA	SHIP WT (LBS)
9030K-513	48"	33"	34.875"	(2) 18"	10.04	(9) 1/3	1/3	115/60/1	9	5-15P	335
9040K-513	60"	33"	34.875"	(2) 24"	14.67	(12) 1/3	1/3	115/60/1	9	5-15P	460
9045K-513	72"	33"	34.875"	(2) 27"	19.3	(15) 1/3	1/3	115/60/1	9	5-15P	475
9050K-513	84"	33"	34.875"	(2) 24", (1) 18"	23.93	(15) 1/3	1/3	115/60/1	9	5-15P	520
9210-513	48"	33"	36"	(2) 18"	12.2	(4) 1/3	1/3	115/60/1	9	5-15P	335
9200-513	60"	33"	36"	(2) 24"	16.5	(5) 1/3	1/3	115/60/1	9	5-15P	460
9230-513	72"	33"	36"	(2) 27"	19.8	(8) 1/3	1/3	115/60/1	9	5-15P	475
9220-513	84"	33"	36"	(2) 24", (1) 18"	20.6	(8) 1/3	1/3	115/60/1	9	5-15P	520

Installation

FAILURE TO FOLLOW INSTALLATION GUIDELINES AND RECOMMENDATIONS MAY VOID THE WARRANTY ON YOUR UNIT.

IT IS IMPORTANT THAT YOUR UNIT HAS ITS OWN DEDICATED LINE. CONDENSING UNITS ARE DESIGNED TO OPERATE WITH A VOLTAGE FLUCTUATION OF PLUS OR MINUS 10% OF THE VOLTAGE INDICATED ON THE UNIT DATA TAG. BURN OUT OF A CONDENSING UNIT DUE TO EXCEEDING VOLTAGE LIMITS WILL VOID THE WARRANTY.

IT IS IMPORTANT THAT A VOLTAGE READING BE MADE AT THE COMPRESSOR MOTOR ELECTRICAL CONNECTIONS, WHILE THE UNIT IS IN OPERATION TO VERIFY THE CORRECT VOLTAGE REQUIRED BY THE COMPRESSOR IS BEING SUPPLIED. LOW OR HIGH VOLTAGE CAN DETRIMENTALLY AFFECT OPERATION AND THEREBY VOID ITS WARRANTY.

ALL SELF-CONTAINED MODELS ARE SHIPPED FROM THE FACTORY WITH THE SERVICE VALES OPEN AND READY FOR OPERATION.

ALL MOTORS ARE OILED AND SEALED.

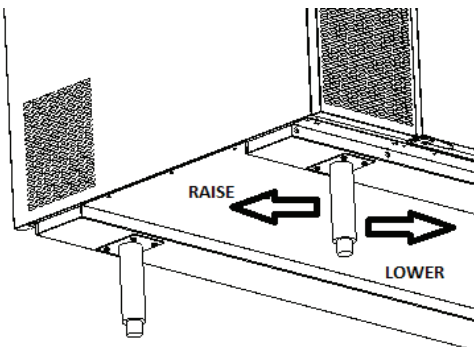

SELECTING A LOCATION FOR YOUR NEW UNIT

The following conditions should be considered when selecting a location for your unit:

1. **Floor and Countertop Load:** The area on which the unit will rest must be level, free of vibration, and suitably strong enough to support the combined weights of the unit plus the maximum product load weight.
2. **Clearance:** Clearance must be a combined total of at least 3" on all sides and back of unit. Do not place any object that can block the ventilation exhaust from the machine compartment register.
3. **Ventilation:** The air cooled self contained unit requires a sufficient amount of cool clean air. Avoid surrounding your unit around other heat generating equipment and out of direct sunlight. Also, avoid locating in an unheated room or where the room temperature may drop below 70°F or rise above 86°F.

INSTALLATION CHECKLIST

After the final location has been determined, refer to the following checklist prior to start-up:

1. Check all exposed refrigeration lines to ensure that they are not kinked, dented, or rubbing together.
2. Check that the condenser and evaporator fans rotate freely without striking any stationary members.
3. Unit must be properly leveled; check all legs or casters to ensure they all are in contact with the floor while maintaining a level work surface. Adjusting bullet feet heights or shimming casters may be necessary if the floor is not level. NOTE: Damage to equipment may result if not followed. Unified Brands is not responsible for damage to equipment if improperly installed.
4. Allow unit time to cool down to temperature. If temperature adjustments are required, the control is located on the front panel. Confirm that the unit is holding the desired temperature.
5. Refer to the front of this manual for serial number location. Please record this information in your manual on page 3 now. It will be necessary when ordering replacement parts or requesting warranty service.
6. Before putting in food, allow your unit to operate for approximately two (2) hours so that interior of the unit is cooled down to storage temperature.
7. Check doors to ensure there is proper sealing and alignment.
8. For units with self-closing doors: Check doors to ensure they open and shut freely.

ELECTRICAL SUPPLY

Any wiring should be done by a qualified electrician in accordance with all national and local electrical codes. A properly wired and grounded outlet will assure proper operation. Please consult the data tag attached to the compressor to ascertain the correct electrical requirements. Supply voltage and amperage requirements are located on the serial number tag (see page 3 for location).

OPTIONAL BULLET-FEET ADJUSTMENT

The legs are equipped with bullet-type leveling bolts. Turn bolts clockwise or counterclockwise until the unit is level (both right to left and front to back). This can be done by hand or with an open end wrench. (See image at left)

Operation



Allow unit to operate for approximately two (2) hours before placing in food.

AMBIENT CONDITIONS

This unit is designed for operation in a room ambient of maximum 70-86°F and 55% relative humidity or less. Operating outside of those temperature may cause premature product wear or failure. It should never be used outside or located in direct sunlight.

Unified Brands has attempted to preset the temperature control to ensure that your unit runs at an optimum temperature, but due to varying ambient conditions, including elevation, food type and your type of operation, you may need to alter this temperature using control adjustment until desired temperature is reached.

Condiments pans will maintain proper temperatures when utilized properly. It is strongly recommended that standard hooded roll covers be kept in the closed position when the unit is not in used and between rush periods. It is also required that the standard hood covers remain on the unit at all times to maintain proper product temperatures. This is especially important in the summer and in kitchens exceeding 80°F. Do not leave the covers open for prolonged periods. All individual condiment pans need to be in the rail at all times. NOTE: If no product is available nor necessary, fill empty pans with 1 to 2 inches of water as an insulating barrier.

Before making temperature adjustments:

1. Make sure that you are allowing adequate time for the cabinet temperature to equalize. When initially started or when first loaded, it can take a long time for temperatures in the display area to stabilize.
2. Make sure that unit operation is not being effected by room ambient conditions. (See Ambient Conditions section above). If there are any significant ambient issues, adjusting the temperature setting may not help.

TO RAISE TEMPERATURE

1. Turn knob counterclockwise, keeping the arrow on the knob pointed within the arc.
2. Turning counterclockwise beyond the arc can result in shutting off of the compressor.

TO LOWER TEMPERATURE

1. Turn knob clockwise, keeping the arrow on the knob pointed within the arc.
2. Turning clockwise beyond the arc can result in freeze-up.

DOOR ADJUSTMENT

The doors are mounted to the cabinet with two screws on the upper hinge, and a hinge pin on the bottom. To adjust the door, first open it to 90° and loosen the two screws enough to reposition the door. Once repositioned, retighten all screws.

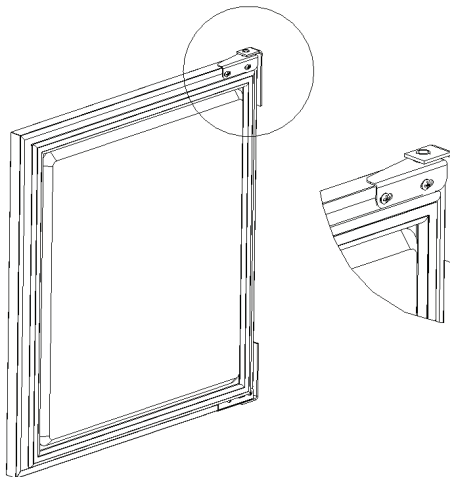

Maintenance

DO NOT USE SHARP UTENSILS AND/OR OBJECTS.

DO NOT USE STEEL PADS, WIRE BRUSHES, SCRAPERS, OR CHLORIDE CLEANERS TO CLEAN YOUR STAINLESS STEEL.

**CAUTION
DO NOT USE ABRASIVE CLEANING SOLVENTS, AND NEVER USE HYDROCHLORIC ACID (MURIATIC ACID) ON STAINLESS STEEL.**

DO NOT PRESSURE WASH EQUIPMENT AS DAMAGE TO ELECTRICAL COMPONENTS MAY RESULT.

Unified Brands strongly suggests a preventive maintenance program which would include the following **Monthly** procedures:

1. Cleaning of all condenser coils. Condenser coils are a critical component in the life of the compressor and must remain clean to assure proper air flow and heat transfer. Failure to maintain this heat transfer will affect unit performance and eventually destroy the compressor. Clean the condenser coils with coil cleaner and/or a vacuum cleaner and brush. NOTE: Brush coil in direction of fins, normally vertically as to not damage or restrict air from passing through condenser.
2. Clean fan blades on the condensing unit and evaporator assembly.
3. Clean and disinfect drain lines and evaporator pan with a solution of warm water and mild detergent.
4. Clean all gaskets on a weekly if not daily basis with a solution of warm water and a mild detergent to extend gasket life.
5. Lubricate door hinges with lithium grease.

RECOMMENDED CLEANERS FOR YOUR STAINLESS STEEL INCLUDE THE FOLLOWING:

JOB	CLEANING AGENT	COMMENTS
Routine cleaning	Soap, ammonia, detergent Medallion	Apply with a sponge or cloth
Fingerprints and smears	Arcal 20, Lac-O-Nu, Ecoshine	Provides a barrier film
Stubborn stains and discoloration	Cameo, Talc, Zud, First Impression	Rub in the direction of the polish lines
Greasy and fatty acids, blood, burnt-on foods	Easy-Off, Degrease It, Oven Aid	Excellent removal on all finishes
Grease and Oil	Any good commercial detergent	Apply with a sponge or cloth
Restoration/Preservation	Benefit, Super Sheen	Good idea monthly

Reference: Nickel Development Institute, Diversey Lever, Savin, Ecolab, NAFEM

Proper maintenance of equipment is the ultimate necessity in preventing costly repairs. By evaluating each unit on a regular schedule, you can often catch and repair minor problems before they completely disable the unit and become burdensome on your entire operation.

For more information on preventive maintenance, consult your local service company or CFESA member. Most repair companies offer this service at very reasonable rates to allow you the time you need to run your business along with the peace of mind that all your equipment will last throughout its expected life. These services often offer guarantees as well as the flexibility in scheduling or maintenance for your convenience. For a complete listing of current Unified Brands ASA please visit www.unifiedbrands.net.

Unified Brands believes strongly in the products it manufactures and backs those products with one of the best warranties in the industry. We believe with the proper maintenance and use, you will realize a profitable return on your investment and years of satisfied service.

Troubleshooting

This unit is designed to operate smoothly and efficiently if properly maintained. However, the following is a list of checks to make in the event of a problem. Wiring diagrams are found at the end of this manual.

SYMPTOM	POSSIBLE CAUSE	PROCEDURE
Unit does not run	<ol style="list-style-type: none"> 1. No power to unit 2. Power switch in OFF position 3. Temperature control turned off 4. Temperature control faulty 5. Compressor overheated 6. Condenser fan faulty 7. Overload protector faulty 8. Compressor relay faulty 9. Compressor faulty 	<ol style="list-style-type: none"> 1. Plug in unit 2. Switch power switch to ON 3. Check temperature control 4. Test temperature control 5. Clean condenser coil 6. Service condenser fan 7. Test overload 8. Test relay 9. Call for service at 888-994-7636
Unit short cycles	<ol style="list-style-type: none"> 1. Condenser coil dirty 2. Condenser fan faulty 3. Compressor faulty 4. Overload repeatedly tripping 	<ol style="list-style-type: none"> 1. Clean coil 2. Service fan and motor 3. Call for service at 888-994-7636 4. Check outlet voltage
Unit runs constantly	<ol style="list-style-type: none"> 1. Condenser coil dirty 2. Condenser fan faulty 3. Room ambient too high 4. Room humidity too high 5. Frost build up 6. Door gasket damaged 7. Poor door seal 	<ol style="list-style-type: none"> 1. Clean coil 2. Service condenser motor 3. Reduce room temperature 4. Set room lower 5. Defrost evaporator 6. Replace door gasket 7. Check door seal
Unit not cold enough	<ol style="list-style-type: none"> 1. Temperature control set too high 2. Temperature control faulty 3. Condenser coil dirty 4. Refrigerant leaking or contaminated 5. Room ambient too high 6. Room humidity too high 7. Door gasket damaged 8. Poor door seal 9. Evaporator fan faulty 10. Evaporator iced up 	<ol style="list-style-type: none"> 1. Adjust control to lower setting 2. Test control 3. Clean coil 4. Call for service at 888-994-7636 5. Reduce room temperature 6. Set room lower 7. Replace door gasket 8. Check door seal 9. Service evaporator fan 10. Defrost evaporator, Test defrost timer, Test Therm-O-Disc, Test defrost timer
Unit too cold	<ol style="list-style-type: none"> 1. Temperature control set too low 2. Temperature control faulty 	<ol style="list-style-type: none"> 1. Adjust control to raise setting 2. Test control
Unit noisy	<ol style="list-style-type: none"> 1. Compressor mountings loose or hardened 2. Condenser fan damaged or hitting fan shroud 3. Unit not level 4. Evaporator fan damaged or hitting fan shroud 	<ol style="list-style-type: none"> 1. Tighten or replace compressor mountings 2. Inspect condenser fan 3. Adjust leveling feet 4. Inspect evaporator fan
Unit does not defrost	<ol style="list-style-type: none"> 1. Defrost heater faulty 2. Defrost Therm-O-Disc faulty 3. Defrost timer faulty 	<ol style="list-style-type: none"> 1. Test heater 2. Test Therm-O-Disc 3. Test timer
Moisture around door or frame	<ol style="list-style-type: none"> 1. Breaker strip faulty 2. Frame heater faulty 3. Temperature control set too low 	<ol style="list-style-type: none"> 1. Inspect strips 2. Call for service at 888-994-7636 3. Adjust control to raise setting
Ice in drain pan or water in bottom of unit or floor	<ol style="list-style-type: none"> 1. Drain tube clogged 2. Unit not level 	<ol style="list-style-type: none"> 1. Clean drain 2. Adjust leveling feet

When in doubt, turn unit off and call for service at 888-994-7636.

Troubleshooting

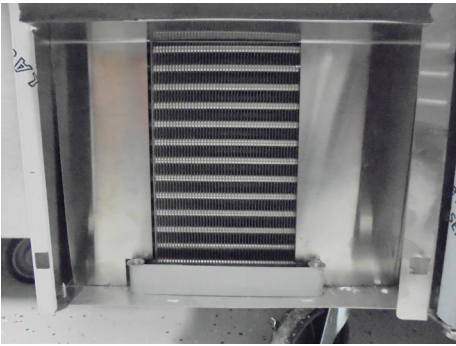

CLEANING CONDENSOR COIL

CLEANING CONDENSOR COIL

An accumulation of dirt and dust prevents the condenser coil from removing, making your unit cool poorly, run constantly, or even stop completely if the compressor overheats. Clean coil using a vacuum cleaner with wand attachment. If the coil is greasy, wash it with a solution of warm water the mild detergent using a bristle brush. Take care not to drip water onto other parts of the condensing unit.



CLEANING DRAIN AND DRAIN PAN

CLEANING DRAIN AND DRAIN PAN

Clean the drain using an oven baster to force a solution of hot water and baking soda or bleach into the drain opening. To clear a stubborn clog, insert a length of 1/4" round plastic tubing into the drain and push it gently through to the drain pan; pull back out. Wash the drain pan regularly with a solution of warm water and baking soda.



CHECKING THE DOOR SEAL

CHECKING THE DOOR SEAL

Open the door and examine all four sides of the door gasket for any tears. Feel the gasket for brittleness and/or cracks. If the gasket shows damage, then it must be replaced. If no damage is observed, close the door and check the seal between the gasket and the cabinet for obvious gaps. Next open the door and close it on a dollar bill. Slowly pull the dollar bill out from the door. If the gasket seals properly, you will feel tension as it grips the bill. Repeat this test all around the door. If the gasket does not seal tightly, replace the gasket after first checking the door for any sagging or warping.



SERVICING THE CONDENSER FAN

SERVICING THE CONDENSER FAN

Inspect the condenser fan motor by removing the mechanical housing cover to gain access. Unplug the unit. Clean the fan blade, and turn it to see if the blade rotates freely. If the motor binds, replace it. If any damage to the blade is observed, unscrew the retaining nut that holds the blade to the motor shaft and pull the blade off the shaft. Install a new fan blade, replacing any washers, and tighten the retaining nut. To test the condenser fan motor, disconnect the wires to the fan motor. Using a multimeter set at RX10, touch one probe to each terminal. The multimeter needle should show approximately 45 to 50 ohms resistance. A lower reading indicates the motor is faulty and needs to be replaced.

Next, set the multimeter at RX1000 and touch one probe to the motor terminals and the other probe to any unpainted metal part of the unit. If the multimeter needle moves, the motor is grounded and needs to be replaced. To remove the motor, unscrew the bracket that holds the fan motor to its housing. Slide the motor out of the housing. Remove the fan blade from the old motor and attach to the new motor, replacing any washers. Install the new motor in its housing by screwing the bracket into place. Reattach the wires to the motor terminals and reconnect the ground wire.

Troubleshooting



SERVICING THE COMPRESSOR

SERVICING THE COMPRESSOR

The compressor is part of the sealed refrigeration system and should be replaced by a professional service technician. You can, however, test the compressor and certain components. Prior to testing, unplug the unit and remove the access cover to the mechanical housing. A small box mounted on the side of the compressor protects the relay, overload protector, and capacitor. Release the wire retaining clip that holds the cover in place and slip off the cover and the clip.

To test the compressor relay, pull the relay straight off the compressor without twisting or damaging it. If the relay has an external wire coil, hold the relay so that the word TOP is up. Using a multimeter set at RX1, place the probes on terminals S and M. The multimeter needle should not move. Remove the probe from terminal M and place it on the side terminal marked L. The multimeter needle should not move. Remove the probe from terminal S and place it on terminal M. The multimeter needle should sweep across the scale, indicating full continuity.

Turn the relay upside down. Using a multimeter set at RX1, place the probes on terminals S and M. The multimeter needle should sweep across the scale, indicating full continuity. Remove the probe from terminal M and place it on the side terminal marked L. The multimeter needle should sweep across the scale, indicating fully continuity. Remove the probe from terminal S and place it on terminal M. The multimeter needle should not move.

If the relay fails any of the tests listed above, the relay is faulty and needs to be replaced. Push a new relay onto the compressor terminals and replace the terminal cover. If the relay passes all the tests listed above, proceed to testing of the overload protector.

To remove the overload protector, use a screwdriver to gently pry open the circular spring clip that secures the overload protector to the compressor and snap out the overload protector. Pull the two wire connectors off the terminals. Using a multimeter set at RX1, touch a probe to each overload protector terminal. The multimeter needle should sweep across the scale, indicating full continuity. If the overload protector passes this test, proceed to testing of the compressor. If the overload protector fails this test, the overload protector is faulty and needs to be replaced. Reattach the push-on connectors to the new overload protector, clip it in place on the compressor, and replace the terminal cover.

For testing the compressor, use a multimeter set at RX1 to test each of the three terminal pins against each of the other two terminal pins. Each pair should show continuity. Then, with the multimeter set at RX1000, place one probe against the metal housing of the compressor (if necessary, scrape off a small amount of paint to ensure contact with bare metal). Place the other probe on each of the three terminals in turn. If any of the three terminals shows continuity with the housing, the compressor is grounded. If the compressor fails either test, call for service at 888-994-7636. If the compressor passes the tests, reinstall the overload protector, relay, terminal cover, and mechanical housing cover.

CALL FACTORY FOR
REPLACEMENT PARTS:
888-994-7636

Parts List

LEFT HINGED DOOR

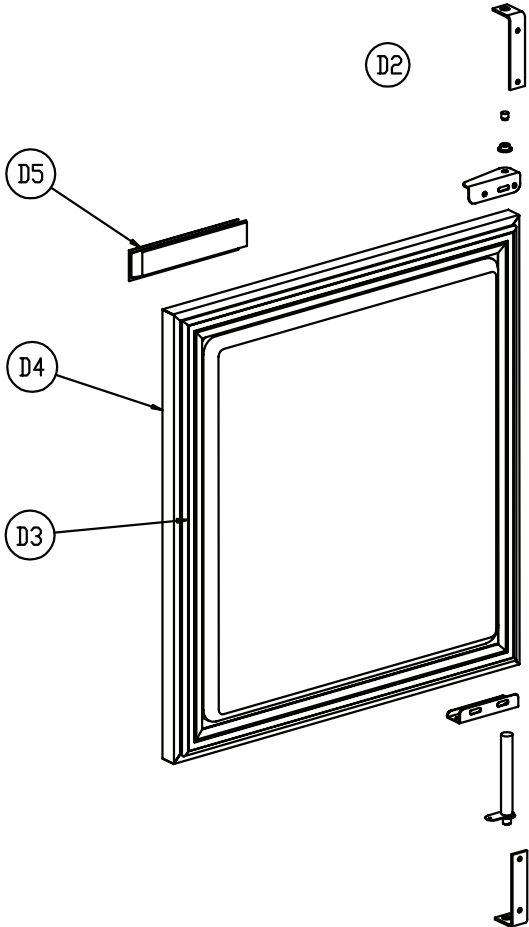

RIGHT HINGED DOOR

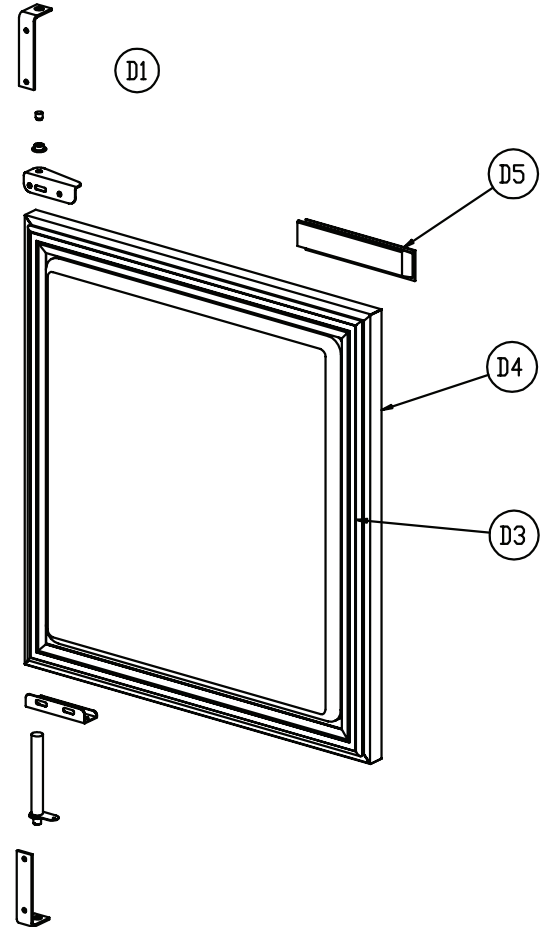

ITEM	SERVICE PART	DESCRIPTION	9030K-513	9040K-513	9045K-513	9050K-513	9210-513	9200-513	9230-513	9220-513
D1	RP HNG9902	HINGE ASSY, SELF CLOSING, RIGHT	X	X	X	X	X	X	X	X
D2	RP HNG9901	HINGE ASSY, SELF CLOSING, LEFT	X	X	X	X	X	X	X	X
D3	IN GSK1020	GASKET, PUSH-IN (LEFT/RIGHT DOORS)	X	--	--	X	X	--	--	X
	IN GSK1025	GASKET, PUSH-IN (LEFT/RIGHT DOORS)	--	X	--	X	--	X	--	X
	IN GSK1030	GASKET, PUSH-IN (LEFT/RIGHT DOORS)	--	--	X	--	--	--	X	--
D4	RP DOR101	DOOR - RIGHT - 18"	X	--	--	X	X	--	--	X
	RP DOR102	DOOR - LEFT - 18"	X	--	--	X	X	--	--	X
	RP DOR103	DOOR - RIGHT - 24"	--	X	--	X	--	X	--	X
	RP DOR104	DOOR - LEFT - 24"	--	X	--	X	--	X	--	X
	RP DOR105	DOOR - RIGHT - 27"	--	--	X	--	--	--	X	--
	RP DOR106	DOOR - LEFT - 27"	--	--	X	--	--	--	X	--
D5	HD HDL0103	HANDLE, BLACK PLASTIC	X	X	X	X	X	X	X	X

CALL FACTORY FOR
REPLACEMENT PARTS:
888-994-7636

Parts List

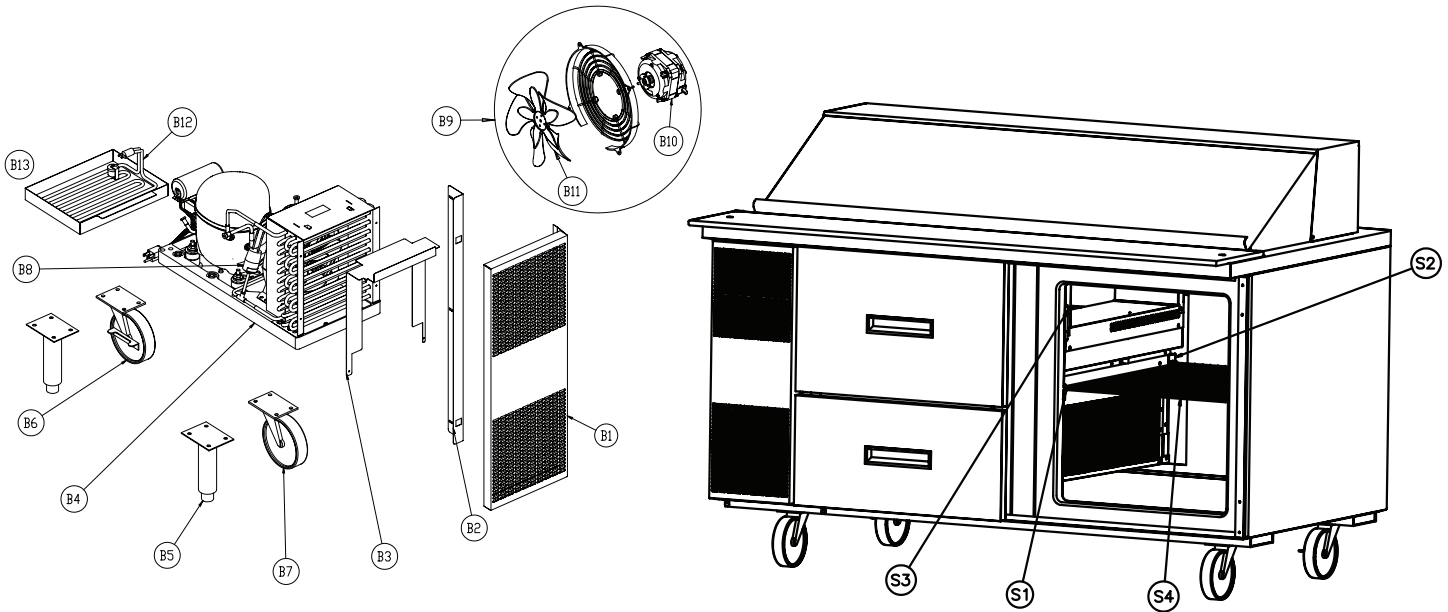

ITEM	SERVICE PART	DESCRIPTION	9030K-513	9040K-513	9045K-513	9050K-513	9210-513	9200-513	9230-513	9220-513
B1	RP LVR0513-D17	LOUVER PANEL, T07-1025A-D17	X	X	--	--	X	X	X	X
	RP LVR0514-D17	LOUVER PANEL, T07-1025B-D17	--	--	X	--	X	X	X	X
	RP LVR0515-D17	LOUVER PANEL, T07-1025C-D17	--	--	--	X	X	--	--	X
B2	RP CLP0907-D17	LOUVER CLIP, T07-1026-D17	X	X	X	X	--	X	--	X
B3	RP SHD1714	CONDENSER SHROUD, 48" & 60" UNITS	X	X	--	--	--	--	X	--
	RP SHD1715	CONDENSER SHROUD, 9230 (t07-1028D-D17)	--	--	--	--	X	--	--	X
	RP SHD1716	CONDENSER SHROUD, 9045/9050	--	--	X	X	X	--	--	X
	RP SHD1717	CONDENSER SHROUD, 9220	--	--	X	--	--	X	--	X
B4	RF CON1701	CONDENSING UNIT, AE4450Y	--	--	X	X	--	X	--	X
	RF CON1702	CONDENSING UNIT, AE4440Y	X	X	--	--	--	--	X	--
	RF CON1416	CONDENSING UNIT, AE4450Y	--	--	--	--	--	--	X	--
	RF CON1420	CONDENSING UNIT, AE4440Y	--	--	--	--	X	X	X	X
B5	HD LEG9902	BULLET LEG (STANDARD)	X	X	X	X	X	X	--	--
B6	HD CST060	LOCKING CASTER (OPTION)	X	X	X	X	--	--	X	
B7	HD CST061	NON-LOCKING CASTER (OPTION)	X	X	X	X	--	--	--	X
B8	RF FLT251	FILTER DRYER	X	X	X	X	X	X	X	X
B9	RF ASY1200P	CONDENSER FAN MOTOR ASSEMBLY, AE4440Y	X	X	--	--	X	X	--	--
B10	EL MTR0102	CONDENSER FAN MOTOR ONLY, 9WATT	X	X	X	X	--	--	X	--
B11	RF BLD1504	BLADE, CONDENSER FAN MOTOR	X	X	X	X	--	--	--	--
B12	EL WIR274	CONDENSATE PAN HEATER, 200WATT	X	X	X	X	--	--	--	X
B13	RP CPN1601	CONDENSATE PAN ASSEMBLY W/ HEATER	X	X	--	--	--	--	--	--
	RP CPN1709	CONDENSATE PAN ASSEMBLY W/ HEATER	--	--	X	X	--	--	--	--
OPTION	RP BCK0301	SS BACK PANEL, 48"	X	--	--	--	--	--	X	X
OPTION	RP BCK0304	SS BACK PANEL, 60"	--	X	--	--	X	X	--	--
OPTION	RP BCK0113	SS BACK PANEL, 72"	--	--	X	--	X	X	X	X
OPTION	RP BCK0303	SS BACK PANEL, 84"	--	--	--	X	X	X	X	X

ITEM	SERVICE PART	DESCRIPTION	9030K-513	9040K-513	9045K-513	9050K-513	9210-513	9200-513	9230-513	9220-513
S1	HD CLP100	SHELF CLIP	X	X	X	X	X	X	X	X
S2	RP SPT0501	SHELF SUPPORT BRACKET, T07-1501A	X	X	X	X	X	X	X	X
S3	HD THR100	THERMOMETER	X	X	X	X	X	X	X	X
S4	HD SHL060	WIRE SHELF, 19 1/8" X 25 1/4"	--	X	--	X	--	X	--	X
	HD SHL015	WIRE SHELF, 13 1/8" X 25 1/4"	X	--	--	X	X	--	--	X
	HD SHL105	WIRE SHELF, 22" X 25 1/4"	X	--	X	--	--	--	X	--

CALL FACTORY FOR
REPLACEMENT PARTS:
888-994-7636

Parts List

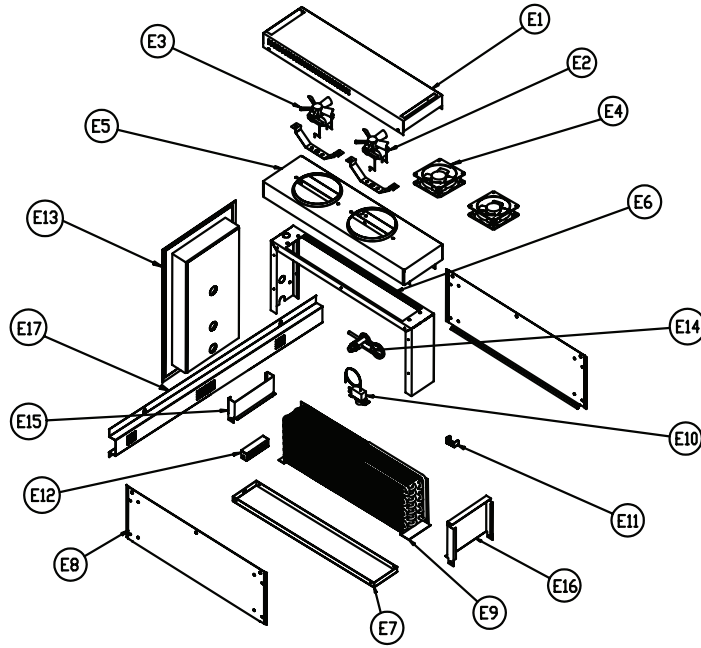

ITEM	SERVICE PART	DESCRIPTION	9030K-513	9040K-513	9045K-513	9050K-513	9210-513	9200-513	9230-513	9220-513
E1	RP SHD0513	EVAP SHROUD GUARD, T07-1504A	X	X	X	X	--	--	--	--
	RP SHD1712	EVAP SHROUD GUARD, T07-1504C	--	--	--	--	X	X	X	X
E2	EL MTR0230	EVAPORATOR FAN MOTOR	X	X	X	X	X	X	X	X
E3	RF FAN006	EVAPORATOR FAN BLADE	X	X	X	X	X	X	X	X
E4	RF FAN1401	FAN, AXIAL 119MM X 38MM	--	--	--	--	X	X	X	X
E5	RP SHD0504	EVAP FAN SHROUD, T07-0528	X	X	X	X	--	--	--	--
	RP SHD1713	EVAP FAN SHROUD, T07-0528-D17	--	--	--	--	X	X	X	X
E6	RP HSG0801	EVAP HOUSING, T07-0521	X	X	X	X	X	X	X	X
E7	RP DRP011	EVAP HOUSING DRAIN PAN	X	X	X	X	X	X	X	X
E8	RP SHD0103	EVAP HOUSING COVER, LEFT SIDE	X	X	X	X	X	X	X	X
	RP SHD0104	EVAP HOUSING COVER, RIGHT SIDE	X	X	X	X	X	X	X	X
E9	RF COI125	EVAPORATOR COIL	X	X	X	X	X	X	X	X
E10	HD CNT1401	THERMOSTAT CONTROL	X	X	X	X	X	X	X	X
E11	RP GRD1701	CONTROL KNOB GUARD	X	X	X	X	X	X	X	X
E12	RP DSN0101	DRAIN COVER	X	X	X	X	X	X	X	X
E13	RP BCK1702	BACK SUPPORT FOR COIL ASSEMBLY	X	X	X	X	X	X	X	X
E14	RF VLV200	EXPANSION VALVE	X	X	X	X	X	X	X	X
E15	RP DCT071	VERTICAL AIR DUCT, EVAP COIL REAR	X	X	X	X	--	--	--	--
E16	RP DCT0702	VERTICAL AIR DUCT, EVAP COIL FRONT	X	X	X	X	X	X	X	X
E17	RP DCT0706	HORIZONTAL AIR DUCT, 9030K	X	--	--	--	--	--	--	--
	RP DCT0709	HORIZONTAL AIR DUCT, 9040K	--	X	--	--	--	--	--	--
	RP DCT0710	HORIZONTAL AIR DUCT, 9045K	--	--	X	--	--	--	--	--
	RP DCT0711	HORIZONTAL AIR DUCT, 9050K	--	--	--	X	--	--	--	--

**CALL FACTORY FOR
REPLACEMENT PARTS:
888-994-7636**

Parts List

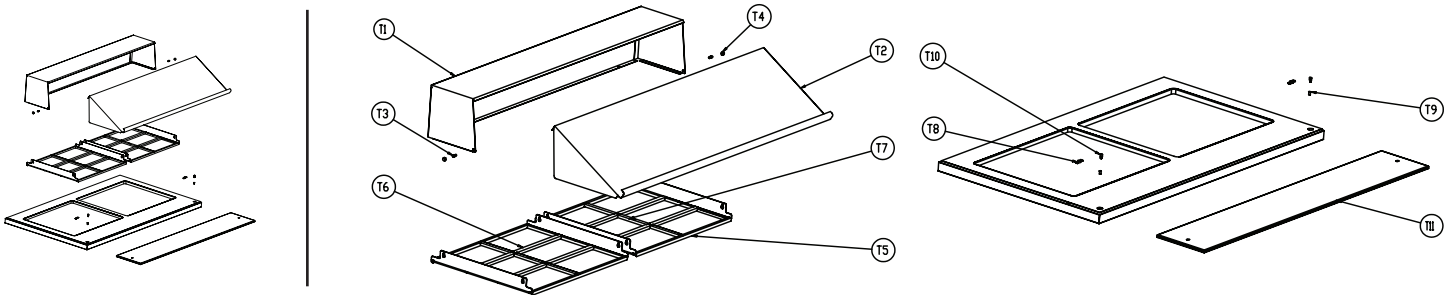

ITEM	SERVICE PART	DESCRIPTION	9030K-513	9040K-513	9045K-513	9050K-513	9210-513	9200-513	9230-513	9220-513
T1	RP COV002	ROLL COVER ASSEMBLY, 9030	X	--	--	--	--	--	--	--
	RP COV003	ROLL COVER ASSEMBLY, 9040	--	X	--	--	--	--	--	--
	RP COV001	ROLL COVER ASSEMBLY, 9045 & 9050	--	--	X	X	--	--	--	--
	RP COV1602	ROLL COVER ASSEMBLY, 9210, 9230, 9220	--	--	--	--	X	--	X	X
	RP ROL0105	ROLL COVER ASSEMBLY, 9200	--	--	--	--	--	X	--	--
T2	RP ROL0305	ROLL COVER FRONT ONLY, 9030	X	--	--	--	--	--	--	--
	RP ROL0303	ROLL COVER FRONT ONLY, 9040	--	X	--	--	--	--	--	--
	RP ROL0304	ROLL COVER FRONT ONLY, 9045 & 9050	--	--	X	X	--	--	--	--
	RP ROL0302	ROLL COVER FRONT ONLY, 9210, 9230, 9220	--	--	--	--	X	--	X	X
	RP ROL10PANF	ROLL COVER FRONT ONLY, 9200	--	--	--	--	--	X	--	--
T3	HD PIN0101	ROLL COVER PIVOT PIN, .875" X 1/4-20	X	X	X	X	X	X	X	X
T4	FA NUT0403SS	NUT, PIVOT PIN 1/4-20 CAP NUT	X	X	X	X	X	X	X	X
T5	RP BAR1204	PAN SUPPORT - FRONT & BACK, 25.8",T07-0087	--	X	X	X	--	--	--	--
	RP BAR1306	PAN SUPPORT - FRONT & BACK, 38.75",T07-0088	X	--	X	X	--	--	--	--
	RP BAR1501	PAN SUPPORT - FRONT & BACK, 27.72",T06-0040B1	--	--	--	--	X	--	X	X
	RP BRK1803	PAN SUPPORT - FRONT & BACK, 34.7",T06-0040C1	--	--	--	--	--	X	--	--
	RP BRK1504	PAN SUPPORT. LEFT, T07-0085	X	X	X	X	--	--	--	--
	RP BRK1505	PAN SUPPORT. RIGHT, T07-0086	X	X	X	X	--	--	--	--
	RP BRK1801	PAN SUPPORT. LEFT, T06-0039B1	--	--	--	--	X	X	X	X
	RP BRK1802	PAN SUPPORT. RIGHT, T06-0039A1	--	--	--	--	X	X	X	X
	RP FRM0017	FRAME ASSEMBLY, 10 PAN SUPPORT	--	--	--	--	--	X	--	--
	RP FRM0201	FRAME ASSEMBLY, 8 PAN SUPPORT	--	--	--	--	X	--	X	X
	RP BRK1801	PAN SUPPORT-LEFT, T06-0039B1	--	--	--	--	X	X	X	X
	RP BRK1802	PAN SUPPORT-RIGHT, T06-0039A1	--	--	--	--	X	X	X	X
T6	RP BAR069	ADAPTER BAR, 12" LOCKING	X	X	X	X	X	X	X	X
T7	RP BAR07K	ADAPTER BAR, 20"	X	X	X	X	--	--	--	--
T8	RP CLP001	CLIP, CUTTING BOARD, SET OF 2	X	X	X	X	X	X	X	X
T9	FA NUT0130	NUTSERT, 10/24 ALUM.	X	X	X	X	X	X	X	X
T10	HD PIN2030	PIN, CUTTING BOARD	X	X	X	X	X	X	X	X
T11	RP CPH1048	POLY CUTTING BOARD, 10" X 48" X .375"	X	--	--	--	--	--	--	--
	RP RCH1048	RICHLITE CUTTING BOARD, 10" X 48" X .5"	X	--	--	--	--	--	--	--
	RP CPH1060	POLY CUTTING BOARD, 10" X 60" X .375"	--	X	--	--	--	--	--	--
	RP RCH1060	RICHLITE CUTTING BOARD, 10" X 60" X .5"	--	X	--	--	--	--	--	--
	RP CPH1072	POLY CUTTING BOARD, 10" X 72" X .375"	--	--	X	--	--	--	--	--
	RP CRH1072	RICHLITE CUTTING BOARD, 10" X 72" X .5"	--	--	X	--	--	--	--	--
	RP CPH1084	POLY CUTTING BOARD, 10" X 84" X .375"	--	--	--	X	--	--	--	--
	RP CRH1084	RICHLITE CUTTING BOARD, 10" X 84" X .5"	--	--	--	X	--	--	--	--
	RP CPH1248	POLY CUTTING BOARD, 12" X 48" X .375"	--	--	--	--	X	--	--	--
	RP CRH1248	RICHLITE CUTTING BOARD, 12" X 48" X .5"	--	--	--	--	X	--	--	--
	RP CPH1260	POLY CUTTING BOARD, 12" X 60" X .375"	--	--	--	--	--	X	--	--
	RP CRH1260	RICHLITE CUTTING BOARD, 12" X 60" X .5"	--	--	--	--	--	X	--	--
	RP CPH1272	POLY CUTTING BOARD, 12" X 72" X .375"	--	--	--	--	--	--	X	--
	RP CRH1272	RICHLITE CUTTING BOARD, 12" X 72" X .5"	--	--	--	--	--	--	X	--
	RP CPH1284	POLY CUTTING BOARD, 12" X 84" X .375"	--	--	--	--	--	--	--	X
	RP CRH1284	RICHLITE CUTTING BOARD, 12" X 84" X .5"	--	--	--	--	--	--	--	X

Electrical Schematic

POWER SUPPLY
115V-60HZ-1PH
CORD WITH GROUND
CAP NEMA #5-15P

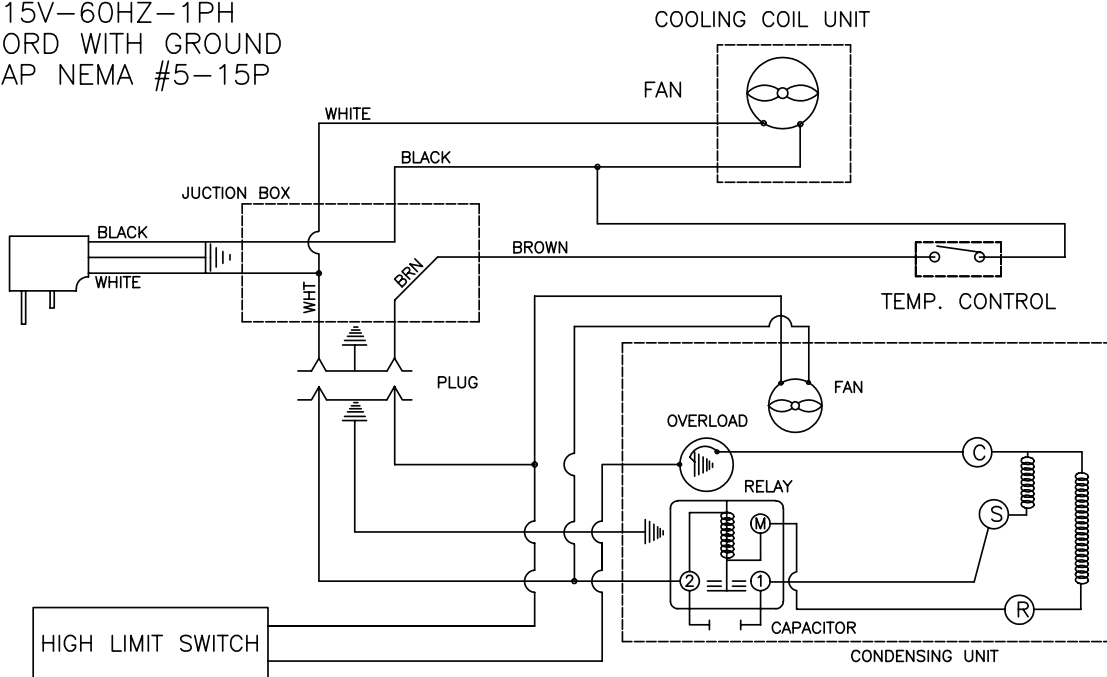

ELECTRICAL DIAGRAM 115 VOLT R-134A REF.

DATE:
07-07-14
REV. _
REV. _

RANDELL MANUFACTURING INC. 0520 SOUTH COLDWATER ROAD
WEIDMAN, MICHIGAN 48803

MODEL: 9000 SERIES W/HIGH LIMIT SWITCH

SCALE
N/A

BY:
ATO

FILE NO.
T12-0101A-D14

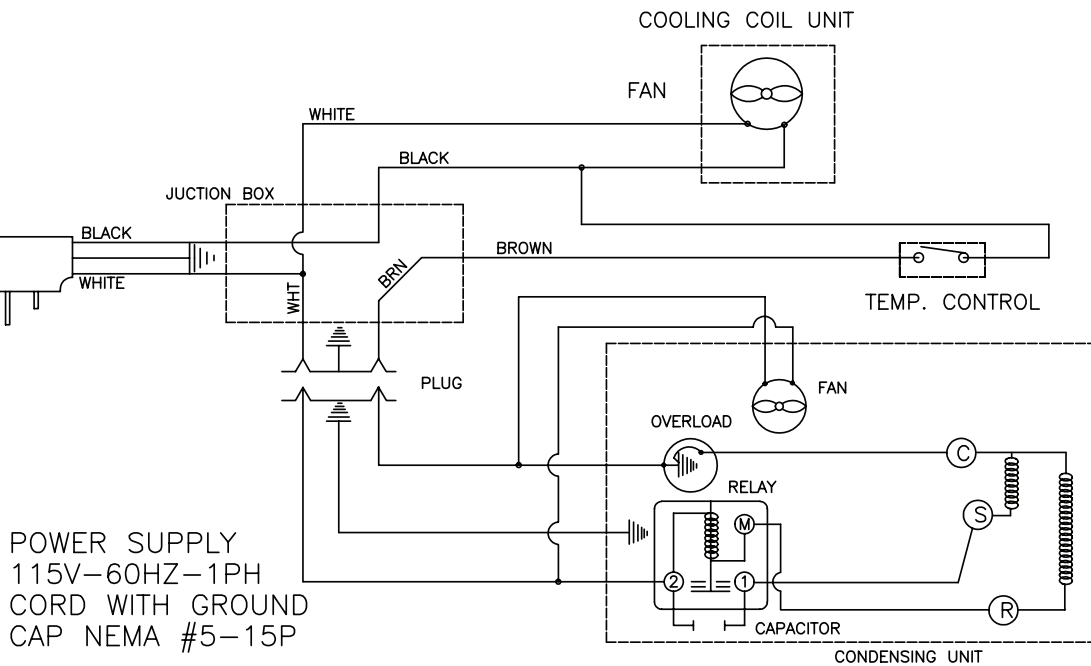

POWER SUPPLY
115V-60HZ-1PH
CORD WITH GROUND
CAP NEMA #5-15P

ELECTRICAL DIAGRAM 115 VOLT R-134A REF.

DATE:
07-07-14
REV. _
REV. _

RANDELL MANUFACTURING INC. 0520 SOUTH COLDWATER ROAD
WEIDMAN, MICHIGAN 48803

MODEL: 9215-32-7

SCALE
N/A

BY:
ATO

FILE NO.
T12-0101A-D14

Warranty Policies

Congratulations on your purchase of a Unified Brands Brand piece of equipment. Unified Brands believes strongly in the products it builds and backs them with the best warranty in the industry. Standard with every unit is the peace of mind that this unit has been thoroughly engineered, properly tested and manufactured to excruciating tolerances, by a manufacturer with over 30 years of industry presence. On top of that front end commitment, Unified Brands has a dedicated staff of certified technicians that monitor our own technical service hotline at **1-888-994-7636** to assist you with any questions or concerns that may arise after delivery of your new Unified Brands equipment.

PARTS WARRANTY

1. One year parts replacement of any and all parts that are found defective in material or workmanship. Unified Brands warrants all component parts of manufactured new equipment to be free of defects in material or workmanship, and that the equipment meets or exceeds reasonable industry standards of performance for a period of one year from the date of shipment from any Unified Brands factory, assembly plant or warehouse facility.

NOTE: warranties are effective from date of shipment, with a thirty day window to allow for shipment, installation and set-up. In the event equipment was shipped to a site other than the final installation site, Unified Brands will warranty for a period of three months following installation, with proof of starting date, up to a maximum of fifteen months from the date of purchase.

2. Free ground freight of customer specified location for all in warranty parts within continental U.S. Component part warranty does not cover glass breakage or gasket replacement. Unified Brands covers all shipping cost related to component part warranty sent at regular ground rates (UPS, USPS). **Freight or postage incurred for any express or specialty methods of shipping are the responsibility of the customer.**

LABOR COVERAGE

In the unlikely event a Unified Brands manufactured unit fails due to defects in materials or workmanship within the first ninety days, Unified Brands agrees to pay the contracted labor rate performed by an Authorized Service Agent (ASA). Any work performed by a non-ASA will not be honored by Unified Brands. Please consult Unified Brands Technical Support (888-994-7636) for a complete listing of ASAs or visit the service page of our website: www.unifiedbrands.net. Warranties are effective from date of shipment, with a thirty day window to allow for shipment, installation and setup. Where equipment is shipped to any site other than final installation, Unified Brands will honor the labor warranty for a period of ninety days following installation with proof of starting date, up to a maximum of six months from date of purchase.

Temperature adjustments are not covered under warranty, due to the wide range of ambient conditions.

To request a warranty approval number, call our Field Service Department at: 1-888-994-7636

WHEN OPTIONAL 5 YEAR COMPRESSOR WARRANTY APPLIES

1. Provide reimbursement to an ASA for the cost of locally obtained replacement compressor in exchange for the return of the defective compressor sent back freight prepaid. **NOTE:** Unified Brands does limit amount of reimbursement allowed and does require bill from local supply house where compressor was obtained (customer should not pay servicing agent up front for compressor).
2. Provide repair at the manufacturing facility by requiring that the defective unit be sent back to Unified Brands freight prepaid. Perform repair at the expense of Unified Brands and ship the item back to the customer freight collect.
3. Furnish a replacement compressor freight collect in exchange for the return of the defective compressor sent back freight prepaid.
4. Furnish complete condensing unit freight collect in exchange for the return of the defective condensing unit sent back freight prepaid. (Decisions on whether or not to send complete condensing units will be made by Unified Brands in-house service technician).

Warranty Policies

WHEN OPTIONAL LABOR EXTENSION POLICY APPLIES

Unified Brands will provide reimbursement of labor to an ASA for any customer that has an optional labor extension of our standard warranty. (Contracted rates do apply) Unified Brands offers both 1 and 2 year extensions. Labor extensions begin at the end of our standard warranty and extend out 9 months to 1 calendar year or 21 months to 2 calendar years from date of purchase. Please contact Unified Brands technical service hotline at 1-888-994-7636 for details and any question on Authorized Service Agents (ASA).

WHEN EXPORT WARRANTIES APPLY

1. Unified Brands covers all non-electrical components under the same guidelines as our standard domestic policy.
2. All electrical components operated on 60Hz are covered under our standard domestic policy.
3. All electrical components operated on 50Hz are covered for 90 days from shipment only.
4. Service labor is covered for the first ninety days with authorization from the factory prior to service being performed.
5. Inbound costs on factory supplied items to be responsibility of the customer.
6. Extended warranty options are not available for parts, labor, or compressors from the factory.

ITEMS NOT COVERED UNDER WARRANTY

1. Maintenance type of repairs such as condenser cleaning, temperature adjustments, clogged drains, unit leveling and re-application of silicone.
2. Unified Brands does not cover gaskets under warranty. Gaskets are a maintenance type component that are subject to daily wear and tear and are the responsibility of the owner of the equipment. Because of the unlimited number of customer related circumstances that can cause gasket failure all gasket replacement issues are considered non-warranty. Unified Brands recommends thorough cleaning of gaskets on a weekly basis with a mild dish soap and warm water. With proper care Unified Brands gaskets can last up to two years, at which time we recommend replacement of all gaskets on the equipment for the best possible performance.

NOTICE: FOOD LOSS IS NOT COVERED UNDER WARRANTY

3. Repairs caused by abuse such as broken glass, freight damage, or scratches and dents.
4. Electrical component failure due to water damage from cleaning procedures.
5. Improper installation of equipment.
6. Repairs performed outside of Unified Brands' Authorized Service Agent network.

QUOTATIONS

Verbal quotations are provided for customer convenience only and are considered invalid in the absence of a written quotation. Written quotations from Unified Brands are valid for 30 days from quote date unless otherwise specified. Unified Brands assumes no liability for dealer quotations to end-users.

SPECIFICATION & PRODUCT DESIGN

Due to continued product improvement, specification and product design may change without notice. Such revisions do not entitle the buyer to additions. Changes or replacements for previously purchased equipment.

SANITATION & SAFETY REQUIREMENTS

Certain areas require specific annotation requirements other than N.S.F. & U.L. standards. Unified Brands must be advised of these specifications before fabrication of equipment. In these special circumstances, a revised quotation may be required to cover additional costs. Failure to notify Unified Brands before fabrication holds the dealer accountable for all additional charges.

Warranty Policies

CANCELLATIONS

Orders canceled prior to production scheduling entered into engineering/production and cancelled are subject to a cancellation charge (contact factory for details).

STORAGE CHARGES

Unified Brands makes every effort to consistently meet our customer's shipment expectations. If after the equipment has been fabricated, the customer requests delay in shipment, and warehousing is required:

1. Equipment held for shipment at purchasers request for a period of 30 days beyond original delivery date specified will be invoiced and become immediately payable.
2. Equipment held beyond 30 days after the original delivery date specified will also include storage charges.

SHIPPING & DELIVERY

Unified Brands will attempt to comply with any shipping, routing or carrier request designated by dealer, but reserves the right to ship merchandise via any responsible carrier at the time equipment is ready for shipment. Unified Brands will not be held responsible for any carrier rate differences; rate differences are entirely between the carrier and purchaser. Point of shipping shall be determined by Unified Brands (Weidman, MI/Prior, OK). At dealer's request, Unified Brands will endeavor whenever practical to meet dealer's request. Freight charges to be collect unless otherwise noted.

DAMAGES

All crating conforms to general motor carrier specifications. To avoid concealed damage, we recommend inspection of every carton upon receipt. In the event the item shows rough handling or visible damage to minimize liability, a full inspection is necessary upon arrival. Appearance of damage will require removing the crate in the presence of the driver. **A notation must be placed on the freight bill and signed for by the truck driver at the time of delivery.** Any and all freight damage that occurs to a Unified Brands piece of equipment as a result of carrier handling is not considered under warranty, and is not covered under warranty guidelines. Any freight damage incurred during shipping needs to have a freight claim filed by the receiver with the shipping carrier. Consignee is responsible for filing of freight claims when a clear delivery receipt is signed. Claims for damages must be filed immediately (within 10 days) by the consignee with the freight carrier and all cartons and merchandise must be retained for inspection. Internal or concealed damage may fall under Unified Brands responsibility dependent upon the circumstances surrounding each specific incident and are at the discretion of the Unified Brands in-house service technician.

RETURNED GOODS

Authorization for return must first be obtained from Unified Brands before returning any merchandise. Any returned goods shipment lacking the return authorization number will be refused, all additional freight costs to be borne by the returning party. Returned equipment must be shipped in original carton, freight prepaid and received in good conditions. Any returned merchandise is subject to a minimum handling charge (contact factory for details).

INSTALLATION

Equipment installation is the responsibility of the dealer and/or their customer. Unified Brands requires all equipment to be professionally installed.

PENALTY CLAUSES

Dealer penalty clauses, on their purchase order or contractually agreed to between the dealer and their clients are not binding on Unified Brands. Unified Brands does not accept orders subject to penalty clauses. This agreement supersedes any such clauses in dealer purchase orders.

*FOOTNOTES IN REFERENCE TO PARAGRAPHS ABOVE

1. NET means list price less discount, warranty, labor policy, freight, Unified Brands delivery and other miscellaneous charges.

CASH DISCOUNTS WILL BE CALCULATED ON NET ONLY.



1055 Mendell Davis Drive • Jackson MS 39272
888-994-7636 • 601-372-3903 • Fax 888-864-7636
unifiedbrands.net