



# OPERATOR MANUAL

IMPORTANT INFORMATION, KEEP FOR OPERATOR

888-994-7636, fax 888-864-7636  
randell.com

THIS MANUAL MUST BE RETAINED FOR FUTURE REFERENCE. READ, UNDERSTAND AND FOLLOW THE INSTRUCTIONS AND WARNINGS CONTAINED IN THIS MANUAL.

**FOR YOUR SAFETY** Do not store or use gasoline or other flammable vapors and liquids in the vicinity of this or any other appliance.

**WARNING R290 flammable refrigerant in use.** Improper installation, adjustment, alteration, service or maintenance can cause property damage, injury or death. Read the installation, operating and maintenance instructions thoroughly before installing or servicing this equipment.

**NOTIFY CARRIER OF DAMAGE AT ONCE** It is the responsibility of the consignee to inspect the container upon receipt of same and to determine the possibility of any damage, including concealed damage. Randell suggests that if you are suspicious of damage to make a notation on the delivery receipt. It will be the responsibility of the consignee to file a claim with the carrier. We recommend that you do so at once.

**Manufacture Service/Questions 888-994-7636.**

This manual provides information for:

## 9200-290 SIDEMOUNT REFRIGERATOR SERIES

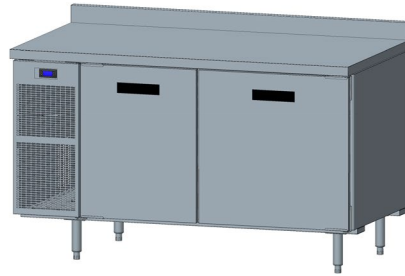

### RETAIN THIS MANUAL FOR FUTURE REFERENCE

**NOTICE:** Due to a continuous program of product improvement, Randell reserves the right to make changes in design and specifications without prior notice.

**NOTICE:** Please read the entire manual carefully before installation. If certain recommended procedures are not followed, warranty claims will be denied.

MODEL NUMBER \_\_\_\_\_

SERIAL NUMBER \_\_\_\_\_

INSTALLATION DATE \_\_\_\_\_

The serial number is located in the cabinet left side or back wall closest to the compressor compartment under the drawer track. An example is shown here.



SERIAL NUMBER XXXXXXXXX  
MODEL NUMBER XXXXXXXXX  
DESCRIPTION

### EQUIPMENT DESCRIPTION

MODEL	LENGTH	DEPTH	HEIGHT	DOORS	STORAGE CU. FT.	HP	VOLT/CYCLE/PHASE	AMPS	NEMA PLUG	SHIP WT.
9215-290	48"	33"	36"	(2) 18"	10.1	1/5	115/60/1	6	5-15P	411
9205-290	60"	33"	36"	(1) 21", (1) 27"	14.7	1/4	115/60/1	6	5-15P	456
9235-290	72"	33"	36"	(2) 27"	19.2	1/4	115/60/1	6	5-15P	502
9225-290	84"	33"	36"	(1) 18", (2) 27"	24.15	1/4	115/60/1	6	5-15P	565



Information contained in this document is known to be current and accurate at the time of printing/creation. Reference our product line website for the most updated product information and specifications. © 2025 Electrolux Professional, Inc. All Rights Reserved.

## IMPORTANT - READ FIRST - IMPORTANT

### INTERIOR EVAPORATOR COVER

 <b>DANGER</b> RISK OF FIRE OR EXPLOSION. FLAMMABLE REFRIGERANT USED. DO NOT USE MECHANICAL DEVICES TO DEFROST REFRIGERATOR. DO NOT PUNCTURE REFRIGERANT TUBING. RISQUE D'INCENDIE OU D'EXPLOSION. INFLAMMABLE REFRIGERANT UTILISÉ. NE PAS UTILISER DE DISPOSITIFS MÉCANIQUES POUR DÉGIVRER LE RÉFRIGÉRATEUR. NE FAIRE AUCUN TUBE RÉFRIGÉRANT DE PUNCTON. RISGO DE INCENDIO O EXPLOSIÓN. REFRIGERANTE INFLAMMABLE UTILIZADO. NO UTILICE DISPOSITIVOS MECÁNICOS PARA DESCONGELAR EL REFRIGERADOR. NO PERFORE LA TUBERÍA DEL REFRIGERANTE. PP.LB1701 REV B	 <b>WARNING ALERTE</b> DO NOT REMOVE PANEL - HIGH VOLTAGE - QUALIFIED PERSONNEL ONLY NE PAS RETIRE LE PANNEAU - HAUTE TENSION - PERSONNEL QUALIFIÉ SEULEMENT NO RETIRE EL PANEL - ALTA TENSION - CALIFICADO PERSONAL  <b>CAUTION ATTENTION</b> MOVING PARTS. DO NOT OPERATE WITH COVER REMOVED PIÈCES MOBILES NE PAS FAIRE FONCTIONNER SANS COUVERCLE LAS PIEZAS DE MOVIMIENTO NO FUNCIONAN CON LA CUBIERTA RETIRADA SBL 1.2
---	--

### EXTERIOR OF UNIT

 <b>CAUTION</b> RISK OF FIRE OR EXPLOSION. DISPOSE OF PROPERLY IN ACCORDANCE WITH FEDERAL OR LOCAL REGULATIONS. FLAMMABLE REFRIGERANT USED. RISQUE D'INCENDIE OU D'EXPLOSION. ÉLIMINER (or DISPOSER) CORRECTEMENT CONFORMÉMENT AUX RÉGLEMENTATIONS FÉDÉRALES OU LOCALES. REFRIGÉRANT INFLAMMABLE UTILISÉ. RISGO DE INCENDIO O EXPLOSIÓN. DESECHÉLO ADECUADAMENTE CONFORME A REGLAMENTOS FEDERALES O LOCALES. REFRIGERANTE INFLAMMABLE UTILIZADO. PP.LB1704 REV B	 <b>MISE EN GARDE RISQUE D'INCENDIE OU D'EXPLOSION.</b> ÉLIMINER (or DISPOSER) CORRECTEMENT CONFORMÉMENT AUX RÉGLEMENTATIONS FÉDÉRALES OU LOCALES. REFRIGÉRANT INFLAMMABLE UTILISÉ. RISQUE D'INCENDIE OU D'EXPLOSION. REFRIGÉRANT INFLAMMABLE UTILISÉ. CONSULTER LE MANUEL DE RÉPARATION / GUIDE DE L'UTILISATEUR AVANT D'ESSAYER D'INSTALLER OU DE RÉPARER CE PRODUIT. TOUTES LES PRÉCAUTIONS DOIVENT ÊTRE RESPECTÉES. RISGO DE INCENDIO O EXPLOSIÓN. REFRIGERANTE INFLAMMABLE UTILIZADO. CONSULTE EL MANUAL DE REPARACIÓN / MANUAL DEL USUARIO ANTES DE INSTALAR O REPARAR ESTE PRODUCTO. DEBEN SEGUIRSE LAS PRECAUCIONES DE SEGURIDAD. SBL 1.3.1
---	---

### NEAR EXPOSED REFRIGERANT TUBING

 <b>CAUTION</b> RISK OF FIRE OR EXPLOSION DUE TO PUNCTURE OF REFRIGERANT TUBING; FOLLOW HANDLING INSTRUCTIONS CAREFULLY. FLAMMABLE REFRIGERANT USED. RISQUE D'INCENDIE OU D'EXPLOSION EN RAISON DE LA PERFORATION DU TUBE RÉFRIGÉRANT. SUIVEZ ATTENTIVEMENT LES INSTRUCTIONS DE MANIPULATION. REFRIGÉRANT INFLAMMABLE UTILISÉ. RISGO DE INCENDIO O EXPLOSIÓN DEBIDO A LA PERFORACIÓN DE LA TUBERÍA DE REFRIGERANTE. SIGA CUIDADOSAMENTE LAS INSTRUCCIONES DE MANEJO. REFRIGERANTE INFLAMMABLE UTILIZADO. PP.LB1706 REV B	 <b>DANGER</b> RISK OF FIRE OR EXPLOSION. FLAMMABLE REFRIGERANT USED. TO BE REPAIRED ONLY BY TRAINED SERVICE PERSONNEL. DO NOT PUNCTURE REFRIGERANT TUBING. RISQUE D'INCENDIE OU D'EXPLOSION. REFRIGÉRANT INFLAMMABLE UTILISÉ. POUR ÊTRE RÉPARÉ QUE PAR UN TECHNICIEN QUALIFIÉ. NE PAS PERFORER LE TUBE RÉFRIGÉRANT. RISGO DE INCENDIO O EXPLOSIÓN. REFRIGERANTE INFLAMMABLE UTILIZADO. DEBE SER REPARADO SOLAMENTE POR PERSONAL DE SERVICIO CAPACITADO. NO PERFORE LA TUBERÍA DEL REFRIGERANTE. PP.LB1705 REV B
---	---

### NEAR MACHINE COMPARTMENT AND NAMEPLATE

 <b>DANGER</b> RISK OF FIRE OR EXPLOSION. FLAMMABLE REFRIGERANT USED. TO BE REPAIRED ONLY BY TRAINED SERVICE PERSONNEL. DO NOT PUNCTURE REFRIGERANT TUBING. RISQUE D'INCENDIE OU D'EXPLOSION. REFRIGÉRANT INFLAMMABLE UTILISÉ. POUR ÊTRE RÉPARÉ QUE PAR UN TECHNICIEN QUALIFIÉ. NE PAS PERFORER LE TUBE RÉFRIGÉRANT. RISGO DE INCENDIO O EXPLOSIÓN. REFRIGERANTE INFLAMMABLE UTILIZADO. DEBE SER REPARADO SOLAMENTE POR PERSONAL DE SERVICIO CAPACITADO. NO PERFORE LA TUBERÍA DEL REFRIGERANTE. PP.LB1705 REV B	 <b>CAUTION</b> RISK OF FIRE OR EXPLOSION. FLAMMABLE REFRIGERANT USED. CONSULT REPAIR MANUAL / OWNER'S GUIDE BEFORE ATTEMPTING TO INSTALL OR SERVICE THIS PRODUCT. ALL SAFETY PRECAUTIONS MUST BE FOLLOWED. RISQUE D'INCENDIE OU D'EXPLOSION. REFRIGÉRANT INFLAMMABLE UTILISÉ. CONSULTER LE MANUEL DE RÉPARATION / GUIDE DE L'UTILISATEUR AVANT D'ESSAYER D'INSTALLER OU DE RÉPARER CE PRODUIT. TOUTES LES PRÉCAUTIONS DOIVENT ÊTRE RESPECTÉES. RISGO DE INCENDIO O EXPLOSIÓN. REFRIGERANTE INFLAMMABLE UTILIZADO. CONSULTE EL MANUAL DE REPARACIÓN / MANUAL DEL USUARIO ANTES DE INSTALAR O REPARAR ESTE PRODUCTO. DEBEN SEGUIRSE LAS PRECAUCIONES DE SEGURIDAD. SBL 1.3.1
---	--

## INSTALLATION

**CAUTION:** THIS UNIT CONTAINS R290 FLAMMABLE REFRIGERANT. USE CAUTION WHEN HANDLING MOVING AND USE OF THE REFRIGERATOR OR FREEZER. AVOID DAMAGING THE REFRIGERANT TUBING OR INCREASE THE RISK OF A LEAK.

**WARNING:** FAILURE TO FOLLOW INSTALLATION GUIDELINES AND RECOMMENDATIONS MAY VOID THE WARRANTY ON YOUR UNIT.

**WARNING:** IT IS IMPORTANT THAT YOUR UNIT HAS ITS OWN DEDICATED LINE. CONDENSING UNITS ARE DESIGNED TO OPERATE WITH A VOLTAGE FLUCTUATION OF PLUS OR MINUS 10% OF THE VOLTAGE INDICATED ON THE UNIT DATA TAG. BURN OUT OF A CONDENSING UNIT DUE TO EXCEEDING VOLTAGE LIMITS WILL VOID THE WARRANTY.

THE DANFOSS CONTROLLER HAS LOW VOLTAGE PROTECTION AND WILL NOT OUTPUT VOLTAGE TO THE COMPRESSOR IF VOLTAGE IS LESS THAN 104V.

**WARNING:** IT IS IMPORTANT THAT A VOLTAGE READING BE MADE AT THE COMPRESSOR MOTOR ELECTRICAL CONNECTIONS, WHILE THE UNIT IS IN OPERATION TO VERIFY THE CORRECT VOLTAGE REQUIRED BY THE COMPRESSOR IS BEING SUPPLIED. LOW OR HIGH VOLTAGE CAN DETRIMENTALLY AFFECT OPERATION AND THEREBY VOID ITS WARRANTY.

**WARNING:** EVAPORATOR FANS RUN CONTINUOUSLY WHILE THE BASE IS POWERED ON.

**WARNING:** THIS UNIT IS INTENDED FOR USE IN LABORATORIES IN COMMERCIAL, INDUSTRIAL, OR INSTITUTIONAL OCCUPANCIES AS DEFINED IN THE SAFETY STANDARD FOR REFRIGERATION SYSTEMS, ASHRAE 15.

### SELECTING A LOCATION FOR YOUR NEW UNIT

The following conditions should be considered when selecting a location for your unit:

- Floor Load:** The area on which the unit will rest must be level, free of vibration, and suitably strong enough to support the combined weights of the unit plus the maximum product load weight. NOTE: If there is a question pertaining to weight load limits, consult the factory at 1-888-994-7636.
- Clearances:** Unit shall have a clearance of 0 inches at the top, 0 inches at the rear and 0 inches at each side.
- Ventilation:** The air cooled self contained unit requires a sufficient amount of cool clean air. Avoid surrounding your unit around other heat generating equipment and out of direct sunlight. Also, avoid locating in an unheated room or where the room temperature may drop below 70° F (21°C) or above 86°F (32°C). Do not place any object that can block the ventilation exhaust from the machine compartment register.

## INSTALLATION CHECKLIST

After the final location has been determined, refer to the following checklist prior to start-up:

- Check all exposed refrigeration lines to ensure that they are not kinked, dented, or rubbing together or rubbing against any steel.
- Check all visible components for any potential damage.
- Check that the condenser and evaporator fans rotate freely without striking any stationary members.
- Unit must be properly leveled; Check all legs or casters ensure they all are in contact with the floor while maintaining a level work surface. Adjusting bullet feet height or shimming casters may be necessary if the floor is not level. NOTE: Damage to equipment may result if not followed. Randell is not responsible for damage to equipment if improperly installed.
- Plug unit into power source. Unit will come on. If unit does not turn on, refer to controller operation section of this manual to manually turn on the unit.
- Allow unit time to cool down to holding temperature. If temperature adjustments are required, the control is located on the front panel. Confirm that the units is holding the desired temperature.
- If unit has drawers, check drawer to ensure the drawer slides freely and fully extents along with seating in the cabinet properly when closed.
- Refer to the front of this manual for serial number location. Please record this information in your manual on page 1 now. It will be necessary when ordering replacement parts or requesting warranty service.
- Allow your unit to operate for approximately 45 minutes before putting in food in the rail. Allow 2 hours for base of the unit to cool down to storage temperature, prior to loading product. NOTE: All motors are oiled and sealed.

### ELECTRICAL SUPPLY

The wiring should be done by a qualified electrician in accordance with local electrical codes. A properly wired and grounded outlet will assure proper operation. Please consult the data tag attached to the compressor to ascertain the correct electrical requirements. Supply voltage and amperage requirements are located on the serial number tag.

### BULLET-FEET ADJUSTMENT

The legs are equipped with bullet-type leveling bolts. Turn bolts clockwise or counterclockwise until the unit is level (both right to left and front to back). This can be done by hand or with an open end wrench.

## OPERATION



### AMBIENT CONDITIONS

Unit is designed for normal operating temperatures between 70° F (21°C) - 86°F (32°C). Operating outside of those temperatures may cause premature product wear or failure.

Randell has attempted to preset the temperature control to ensure that your unit runs at an optimum temperature, but due to varying ambient conditions, including elevation, food type and your type of operation, you may need to alter this temperature using control adjustment until desired temperature is reached.

Condiments pans will maintain proper temperatures when utilized properly. It is strongly recommended that standard hooded roll covers be kept in the closed position when the unit is not in used and between rush periods. It is also required that the standard hood covers remain on the unit at all times to maintain proper product temperatures. This is especially important in the summer and in kitchens exceeding 80°F (26.7°C). Do not leave the covers open for prolonged periods. All individual condiment pans need to be in the rail at all times. NOTE: If no product is available nor necessary, fill empty pans with 1 to 2 inches of water as an insulating barrier.

### DANFOSS CONTROLLER OPERATION

LED	FUNCTION
	Compressor energized and condenser fan energized
	An alarm is occurring
°C / °F	Temperature unit



**POWER ON / OFF:** Press the power switch to on/off. The LED display will turn on/off with the switch.

#### CHANGE SET POINT:

1. Press and hold the "A" & "V" arrow buttons simultaneously until PAS displays on control.
2. Three zeros will appear. Use arrows to adjust 3 digits to password (357).
3. Press the power button to submit password. PS1 will appear if correct password is entered.
4. PS1 will change to THE (Thermostat). Press the power button to enter the Thermostat menu.
5. SET (Set Point) will appear. Press power again to access set point adjustment.
6. Current set point will appear. Use arrows to adjust set point to desired value.
7. Press power button to set adjustment.
8. Set point has now been adjusted. The display will revert to its standard display after menu timeout expires or the user can press the defrost button which acts as a back button until the standard display is active.

### CHANGE FROM °F /°C :

1. Press the up/down buttons simultaneously for 5 seconds to access the menu.
2. Password is requested. Password is 357.
3. Press the bottom left button to OK the password.
4. Using the up/down buttons, navigate to the "diS" level. Press the bottom left button to OK the selection.
5. Using the up/down buttons, navigate to the "CFu" level. Press the bottom left button to OK the selection.
  - a. "-F" designates Fahrenheit.
  - b. "-C" designates Celsius.
6. Press the top left button repeatedly to return to exit and return to the home screen.

### OPTIONAL DRAWER: REMOVAL (IF APPLICABLE)

1. Fully extend the drawer that is to be removed.
2. Remove product pans from drawer.
3. Lift up the drawer stop tabs on each side of drawer track.
4. Pull drawer out while lifting the tabs.

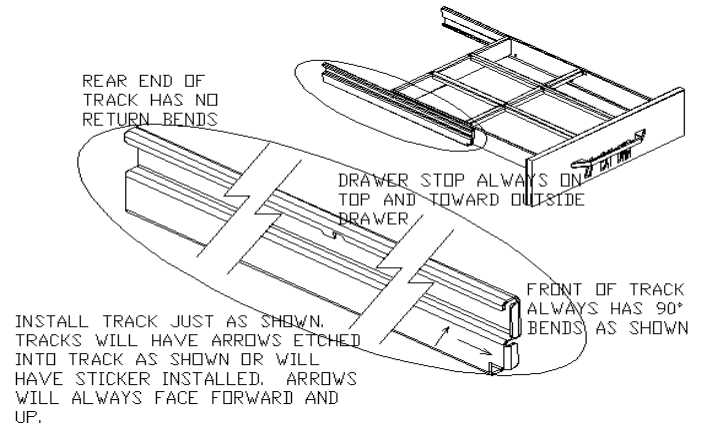
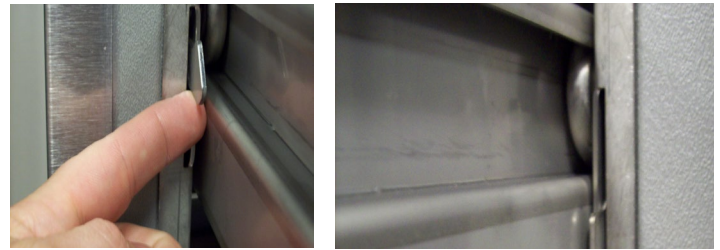

### OPTIONAL DRAWER: INSTALLATION (IF APPLICABLE)

To remove and re-install individual drawers and drawer tracks, please refer to the figure above for proper installation instructions.

## MAINTENANCE

**WARNING: DO NOT USE SHARP UTENSILS AND/OR OBJECTS.**

**WARNING: DO NOT USE STEEL PADS, WIRE BRUSHES, SCRAPERS, OR CHLORIDE CLEANERS TO CLEAN YOUR STAINLESS STEEL.**

**CAUTION: DO NOT USE ABRASIVE CLEANING SOLVENTS, AND NEVER USE HYDROCHLORIC ACID (MURIATIC ACID) ON STAINLESS STEEL.**

**WARNING: DO NOT PRESSURE WASH EQUIPMENT AS DAMAGE TO ELECTRICAL COMPONENTS MAY RESULT.**

Randell strongly suggests a preventive maintenance program which would include the following monthly, weekly, and daily procedures:

If a failure of the equipment is a direct result of any of the Preventative Maintenance guidelines being neglected, the repairs and parts replacements will not be covered under warranty.

It is recommended that the customer contact the local Authorized Service Agent to provide a quote to perform periodic Preventative Maintenance.

### WEEKLY PM PROCEDURES

1. Clean all gaskets on a weekly if not daily basis with a solution of warm water and a mild detergent to extend gasket life. Do not use bleach for cleaning gaskets. Bleach will cause the gaskets to become brittle and not reach their normal life expectancy.

### MONTHLY PM PROCEDURES

1. Cleaning of all condenser coils. Condenser coils are a critical component in the life of the compressor and must remain clean to assure proper air flow and heat transfer. Failure to maintain this heat transfer will affect unit performance and eventually destroy the compressor. Clean the condenser coils with coil cleaner and/or a vacuum cleaner and brush. NOTE: Brush coil in direction of fins, normally vertically as to not damage or restrict air from passing through condenser.
2. Clean fan blades on the condensing unit and evaporator assembly.
3. Clean and disinfect drain lines and evaporator pan with a solution of warm water and mild detergent.
4. Clean all gaskets on a weekly if not daily basis with a solution of warm water and a mild detergent to extend gasket life.
5. Lubricate door hinges with lithium grease.

RECOMMENDED CLEANERS FOR YOUR STAINLESS STEEL INCLUDE THE FOLLOWING:

JOB	CLEANING AGENT	COMMENTS
Routine cleaning	Soap, ammonia, detergent Medallion	Apply with a sponge or cloth
Fingerprints and smears	Arcal 20, Lac-O-Nu, Ecoshine	Provides a barrier film
Stubborn stains and discoloration	Cameo, Talc, Zud, First Impression	Rub in the direction of the polish lines
Greasy and fatty acids, blood, burnt-on foods	Easy-Off, Degrease It, Oven Aid	Excellent removal on all finishes
Grease and Oil	Any good commercial detergent	Apply with a sponge or cloth
Restoration/Preservation	Benefit, Super Sheen	Good idea monthly

Reference: Nickel Development Institute, Diversey Lever, Savin, Ecolab, NAFEM

Proper maintenance of equipment is the ultimate necessity in preventing costly repairs. By evaluating each unit on a regular schedule, you can often catch and repair minor problems before they completely disable the unit and become burdensome on your entire operation.

For more information on preventive maintenance, consult your local service company or CFESA member. Most repair companies offer this service at very reasonable rates to allow you the time you need to run your business along with

the peace of mind that all your equipment will last throughout its expected life. These services often offer guarantees as well as the flexibility in scheduling or maintenance for your convenience. For a complete listing of current Randell ASA please visit [www.unifiedbrands.net](http://www.unifiedbrands.net).

Randell believes strongly in the products it manufactures and backs those products with one of the best warranties in the industry. We believe with the proper maintenance and use, you will realize a profitable return on your investment and years of satisfied service.

## REPLACEMENT PARTS

To order parts, contact your Authorized Service Agent. Supply the model designation, serial number, part description, part number, quantity, and when applicable, voltage and phase.

## CONTACT US

If you have questions pertaining to the content in this manual, contact Randell at 888-994-7636.

## TROUBLESHOOTING

This unit is designed to operate smoothly and efficiently if properly maintained. However, the following is a list of checks to make in the event of a problem. Wiring diagrams are found at the end of this manual. When in doubt, turn unit off and contact service at 888-994-7636.

SYMPTOM	POSSIBLE CAUSE	PROCEDURE
Unit does not run	No power to unit	Plug in unit
	Control in OFF position	Turn controller on
	Faulty control	Call for service at 888-994-7636
Unit too cold	Incorrect set point	Adjust control set point
Unit too warm	Roll cover is open	Close roll cover
	Gasket torn or out of place	Inspect the gasket for wear and position
	Incorrect set point	Adjust control set point
	Warm product introduced to cabinet	Pre-chill product 37°F
	Ice on the coil	Initiate manual defrost
Unit noisy	Ice on the coil	Initiate manual defrost
Unit does not defrost	Excessive ice on the coil	Initiate manual defrost

## DANFOSS CONTROLLER CODES

DISPLAYED ALARM CODE	ALARM	ACTION
Hi	High Temperature Alarm	Inspect door/drawer sealing
		Contact service
Lo	Low Temperature Alarm	Contact service
CON	Condenser Temperature High Limit	Clean condenser coil
		Inspect coil for any objects obstruction hindering airflow
		Contact service
uHi	Line Voltage Too High	Verify voltage of power source, to be performed by qualified technician
		Contact service

DISPLAYED ALARM CODE	ALARM	ACTION
uLi	Line Voltage Too Low	Verify voltage of power source, to be performed by qualified technician Contact service
LEA	Continuous Compressor Runtime	Inspect door/drawer sealing Inspect condenser coil, clean if necessary Contact service
E01	S1 Sensor Failure	Contact service
E02	S2 Sensor Failure	Contact service
E03	S3 Sensor Failure	Contact service
E04	S4 Sensor Failure	Contact service

### CLEANING CONDENSER COIL

An accumulation of dirt and dust prevents the condenser coil from removing, making your unit cool poorly, run constantly, or even stop completely if the compressor overheats. Clean coil using a vacuum cleaner with wand attachment. If the coil is greasy, wash it with a solution of warm water the mild detergent using a bristle brush. Take care not to drip water onto other parts of the condensing unit.

### CLEANING DRAIN AND DRAIN PAN

Clean the drain using an oven baster to force a solution of hot water and baking soda or bleach into the drain opening. To clear a stubborn clog, insert a length of 1/4" round plastic tubing into the drain and push it gently through to the drain pan; pull back out. Wash the drain pan regularly with a solution of warm water and baking soda.

### CHECKING THE DOOR SEAL

Open the door and examine all four sides of the door gasket for any tears. Feel the gasket for brittleness and/or cracks. If the gasket shows damage, then it must be replaced. If no damage is observed, close the door and check the seal between the gasket and the cabinet for obvious gaps. Next open the door and close it on a dollar bill. Slowly pull the dollar bill out from the door. If the gasket seals properly, you will feel tension as it grips the bill. Repeat this test all around the door. If the gasket does not seal tightly, replace the gasket after first checking the door for any sagging or warping.

## SERVICE

**CAUTION: COMPONENT PARTS SHALL BE REPLACED WITH FACTORY OEM PARTS. SERVICE WORK SHALL BE DONE BY FACTORY AUTHORIZED SERVICE PERSONNEL, SO AS TO MINIMIZE THE RISK OF POSSIBLE IGNITION DUE TO INCORRECT PARTS OR IMPROPER SERVICE.**

**CAUTION: BEFORE MAKING ANY REPAIRS, ENSURE THE UNIT IS DISCONNECTED FROM ITS POWER SOURCE.**

This piece of equipment uses a R290 Refrigeration system. This equipment has been clearly marked on the serial tag the type of refrigerant that is being used. There are also warning labels stating that the unit contains R290 refrigerant. To ensure safe servicing and operation these labels must be followed.

No smoking or open flames when servicing this equipment. If needed, use a CO2 or powder type fire extinguisher.

Replacement parts used on any R290 Refrigeration system cabinet must have specific UL certification for non-sparking components.

Only authorized service technician, certified in R290 system should service this equipment.

### SERVICE TOOLS

Use of tools designed for hydrocarbon refrigerant are required for accurate and safe servicing.

- Keep service hoses short and with a small I.D.
- Use precise accurate scales for charging of refrigerant

### REFRIGERANT RECOVERY

Follow all national and local regulations for R-290 refrigerant recovery.

### LEAKING CHECKING AND REPAIR

Leak check an R-290 system the same way you would an R-134a or R-404A system with the following exceptions.

1. Do not use a Halid leak detector on a R290 system.
2. Electronic leak detector must be designated specifically for combustible gas. Use of a bubble solution or an ultrasonic leak detector are acceptable.

When repairing a leak, it is recommended using oxygen free dry nitrogen with a trace gas not exceeding 200PSI.

When accessing an R290 system, piercing valves are not to remain on the equipment in a permanent manner. After charge is recovered, Schrader valves are to be installed on the process stubs. Proper charge is to be weighed into the system and the system is to be leak checked afterwards.

The R290 equipment must have red process tubes and other devices through which the refrigerant is serviced, such as any service port. This color marking must remain on the equipment. If marking is removed, it must be replaced and extend at least 2.5 centimeters (1") from the compressor.

### CHARGING

Follow the charge amount specified on the data tag. It is recommended to use the shortest hoses possible to prevent undercharging.

- Ensure the system is sealed and leak checked
- Evacuate system to a minimum 500 micron
- Weigh in correct charge
- Leak check the system again
- If a manifold was used ensure all refrigerant has been removed from hoses and manifold.
- Disconnect the hoses
- Remove line taps

LEFT HINGED DOOR

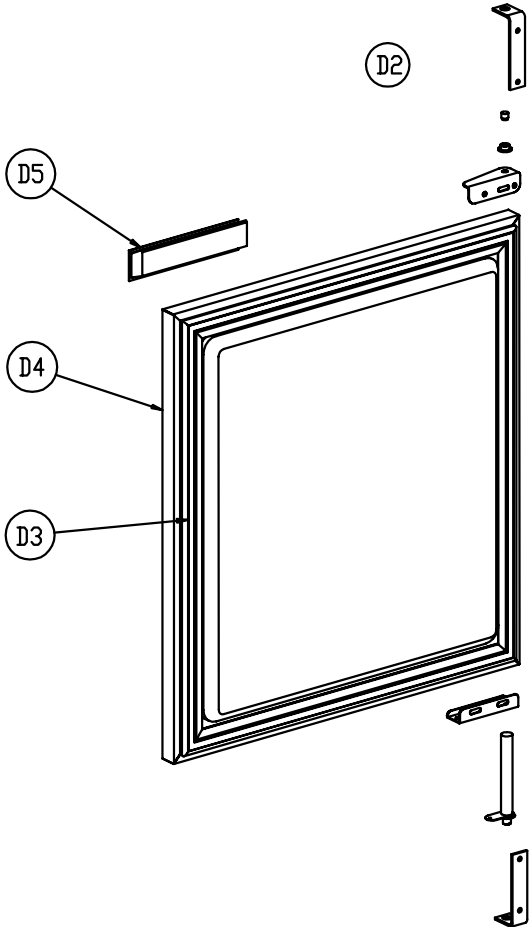

RIGHT HINGED DOOR

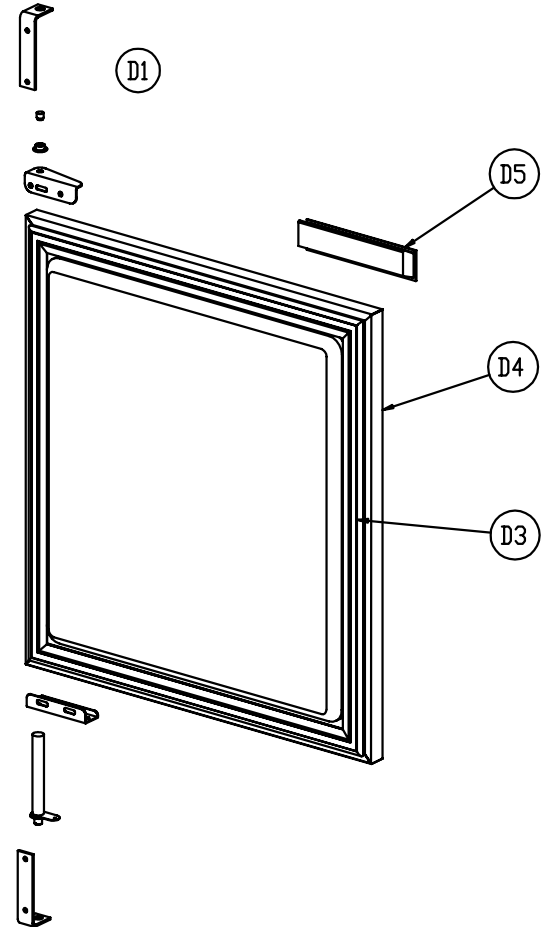

ITEM	SERVICE PART	DESCRIPTION	9215-290	9205-290	9235-290	9225-290
D1	RP HNG9901	HINGE ASSY, SELF CLOSING, RIGHT	X	X	X	X
D2	RP HNG9902	HINGE ASSY, SELF CLOSING, LEFT	X	X	X	X
D3	IN GSK1020	GASKET, PUSH-IN (BOTH LEFT & RIGHT DOORS) - 18"	X	--	--	X
D3	IN GSK9902	GASKET, PUSH-IN (BOTH LEFT & RIGHT DOORS) - 21"	--	X	--	--
D3	IN GSK1030	GASKET, PUSH-IN (BOTH LEFT & RIGHT DOORS) - 27"	--	X	X	X
D4	RP DOR101	DOOR - RIGHT HINGE - 18"	X	--	--	X
D4	RP DOR102	DOOR - LEFT HINGE - 18"	X	--	--	X
D4	RP DOR0209	DOOR - RIGHT HINGE - 21"	--	X	--	--
D4	RP DOR0208	DOOR - LEFT HINGE - 21"	--	X	--	--
D4	RP DOR105	DOOR - RIGHT HINGE - 27"	--	X	X	X
D4	RP DOR106	DOOR - LEFT HINGE - 27"	--	X	X	X
D5	HD HDL0103	HANDLE, BLACK PLASTIC	X	X	X	X

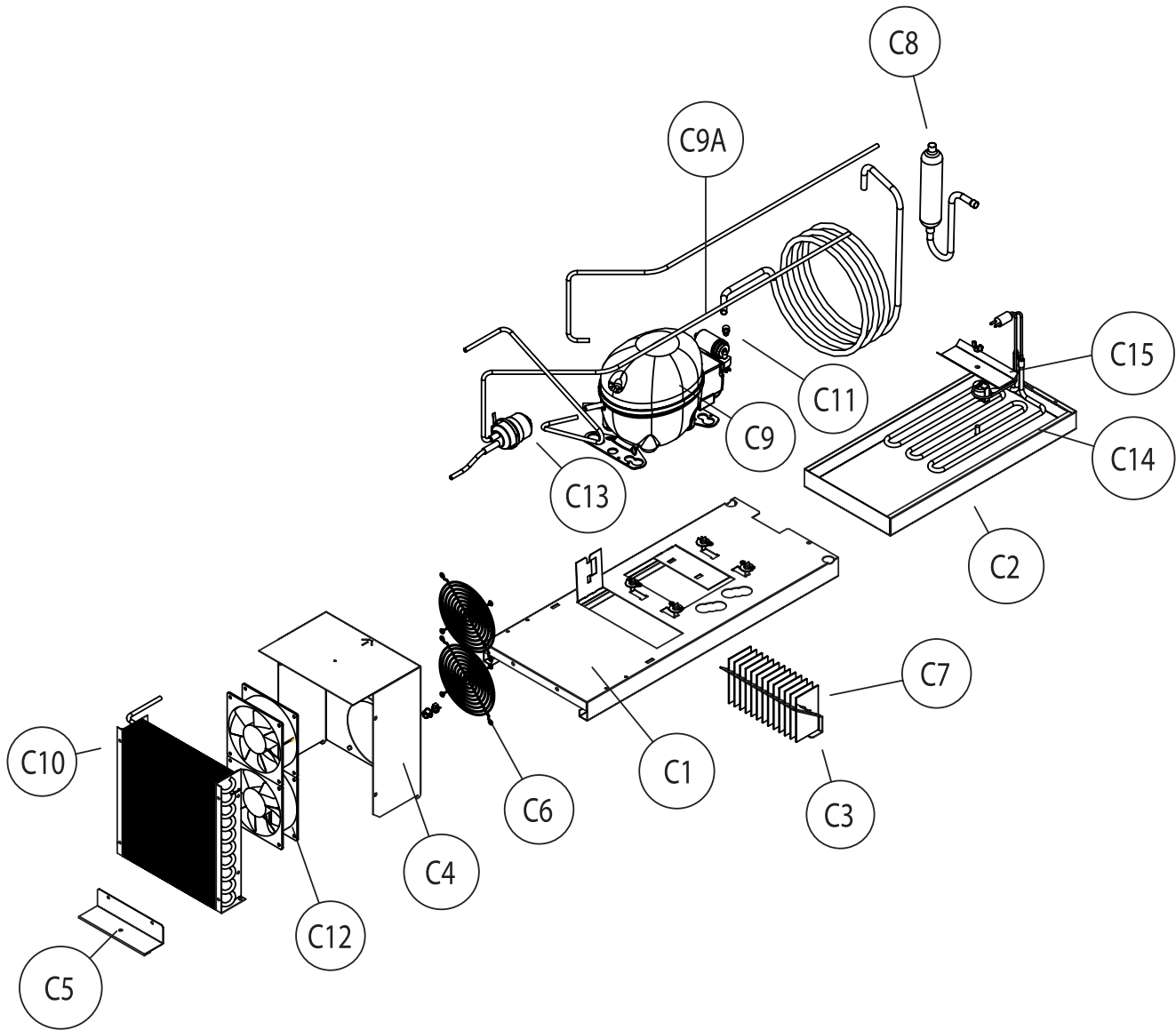

ITEM	SERVICE PART	DESCRIPTION	9215-290	9205-290	9235-290	9225-290
C1	RP MNT2501	COMPRESSOR MOUNT	X	X	X	X
C2	RP MNT2502	DRAIN PAN	X	X	X	X
C3	RP CLP2502	WICKING STRIP HOLDER	X	X	X	X
C4	RP SHD2501	CONDENSER SHROUD	X	X	X	X
C5	RP CLP2501	FRONT MOUNTING CLIP	X	X	X	X
C6	HD GRD1610	FAN GUARD	X	X	X	X
C7	HD WCK1702	WICKING PAD	X	X	X	X
C8	RF ACM1801	ACCUMULATOR	X	X	X	X
C9	RF CMP1801	COMPRESSOR, 1/5HP, 115V-60HZ, R290, EMBRACO, EMX3115U	X	--	--	--
C9A	RF CMP1801SC	COMPRESSOR, 1/5HP, START COMPONENTS	X	--	--	--
C9	RF CMP1604	COMPRESSOR, 1/4HP, R290, EMBRACO, 115V-60HZ, EM2X3125U	--	X	X	X
C9A	RF CMP1604SC	COMPRESSOR, 1/4HP, START COMPONENTS	--	X	X	X
C10	RF COI1603	CONDENSER COIL	X	X	X	X
C11	RF CPL325	COUPLER	X	X	X	X
C12	RF FAN0601	FAN, AXIAL 127 x 38 MM	X	X	X	X
C13	RF FLT9902	FILTER DRIER	X	X	X	X

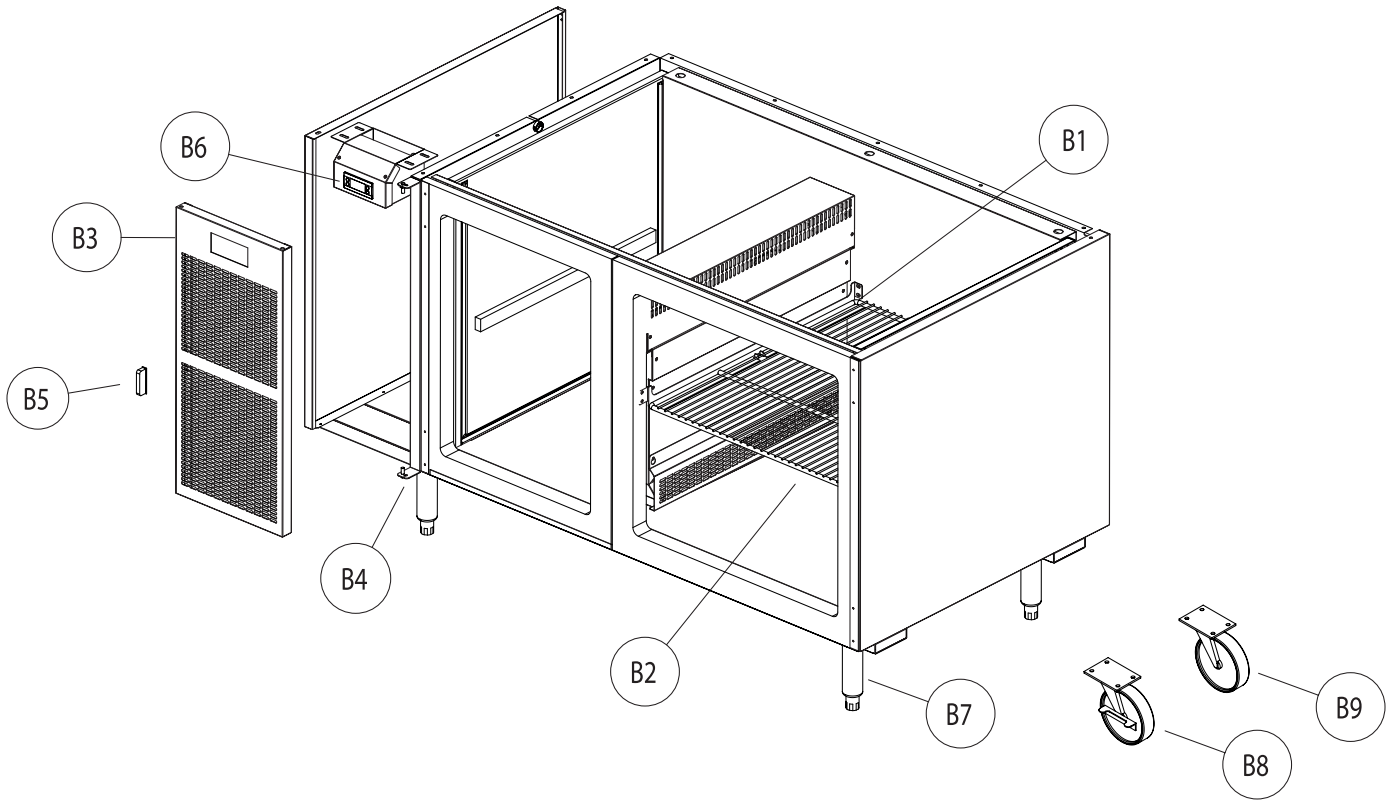

ITEM	SERVICE PART	DESCRIPTION	9215-290	9205-290	9235-290	9225-290
B1	RP SPT2101L	SHELF SUPPORT LEFT OF DOOR, INTERIOR	X	X	X	X
B1	RP SPT2101R	SHELF SUPPORT RIGHT OF DOOR, INTERIOR (NOT SHOWN)	X	X	X	X
B2	HD SHL015	WIRE SHELF, 13 1/8" X 25 1/4"	X	--	--	X
B2	HD SHL9912	WIRE SHELF, 16 1/8" X 25 1/4"	--	X	--	--
B2	HD SHL105	WIRE SHELF, 22" X 25 1/4"	--	X	X	X
B3	RP LVR2501	COMPRESSOR LOUVER, 9200-290	X	X	X	X
B4	RP HNG2101	HINGED LOUVER MOUNTING BRACKET	X	X	X	X
B5	HD CTH9901	CATCH, MAGNETIC	X	X	X	X
B6	RF CNT2105	CONTROL, 9200-290	X	X	X	X
B7	HD LEG9902	6" BULLET LEG (STANDARD)	X	X	X	X
B8	HD CST060	6" LOCKING CASTER (OPTION - NOT SHOWN)	X	X	X	X
B9	HD CST061	6" NON-LOCKING CASTER (OPTION - NOT SHOWN)	X	X	X	X
	RP BCK2106	SS BACK PANEL, 48" (NOT SHOWN)	X	--	--	--
	RP BCK2107	SS BACK PANEL, 60" (NOT SHOWN)	--	X	--	--
	RP BCK2108	SS BACK PANEL, 72" (NOT SHOWN)	--	--	X	--
	RP BCK2109	SS BACK PANEL, 84" (NOT SHOWN)	--	--	--	X

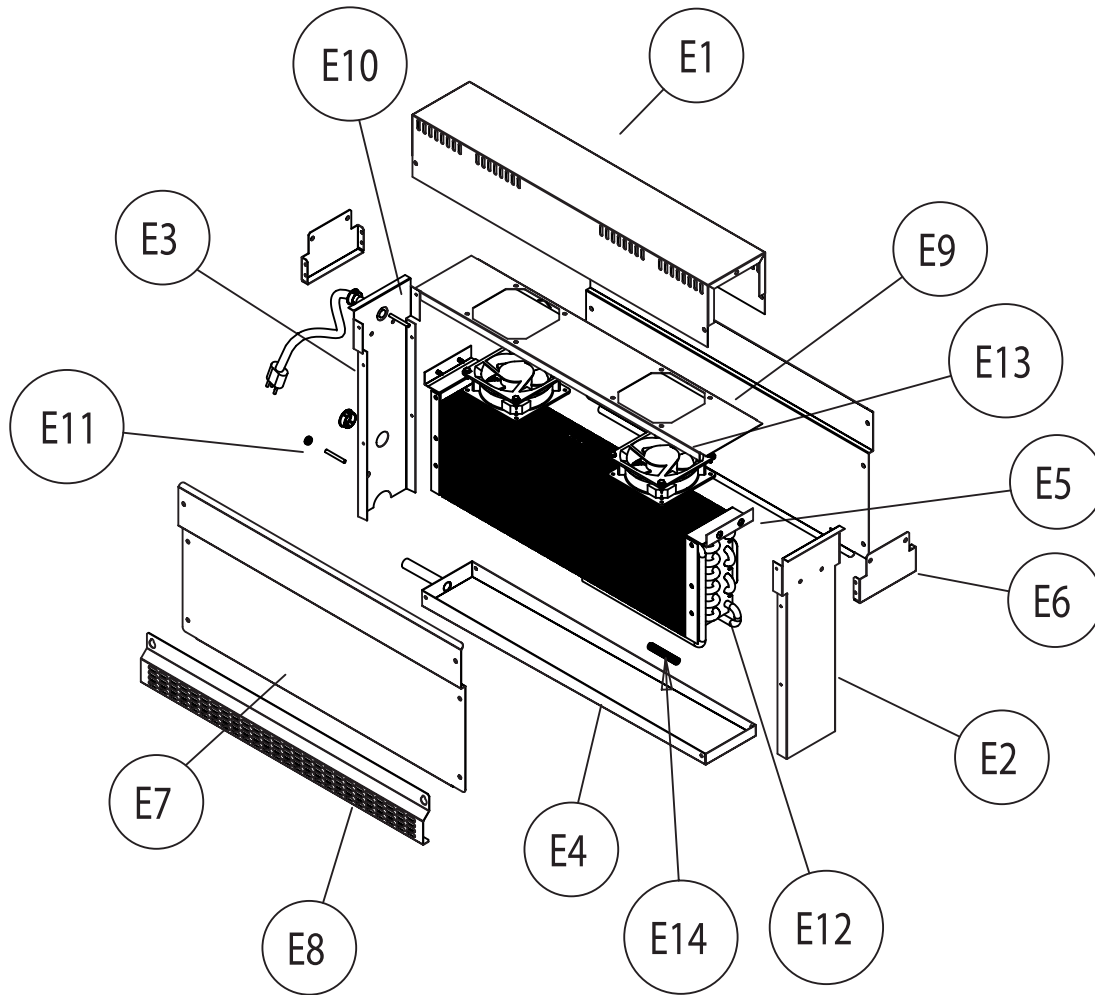

ITEM	SERVICE PART	DESCRIPTION	9205-290	9235-290	9225-290
E1	RP GRD2505	TOP, EVAP COIL, 9205-290, 9235-290	X	X	--
E1	RP GRD2506	TOP, EVAP COIL, 9225-290	--	--	X
E2	RP FRT2512	FRONT, EVAP COIL, WIDE	X	X	X
E3	RP BCK2502	REAR, EVAP COIL, WIDE	X	X	X
E4	RP DRP2501	PAN, DRAIN	X	X	X
E5	RP GRD2102	BRACKET, EVAP MOUNTING	X	X	X
E6	RP GRD2503	BRACKET, COIL MOUNT	X	X	X
E7	RP CVR2502	SIDE, EVAP COIL HOUSING, WIDE	X	X	X
E8	RP GRD2502	GUARD, DRAIN PAN	X	X	X
E9	RP SHD2503	SHROUD, EVAP COIL, TWO FANS, WIDE	X	X	X
E10	RF CNT1602	THERMISTOR, COIL DEFROST, BLUE	X	X	X
E11	RF CNT1603	THERMISTOR, COIL AIR, BLACK	X	X	X
E12	RF COI125	4 X 7.5 X 21IN MULLION COIL	X	X	X
E13	RF FAN1401	FAN, EVAPORATOR, 119MM X 38MM	X	X	X
E14	T07-2159	CAPILLARY TUBE, 0.044 X 0.093 CAP, 132IN LONG, 3FT/7FT/11FT	X	X	X

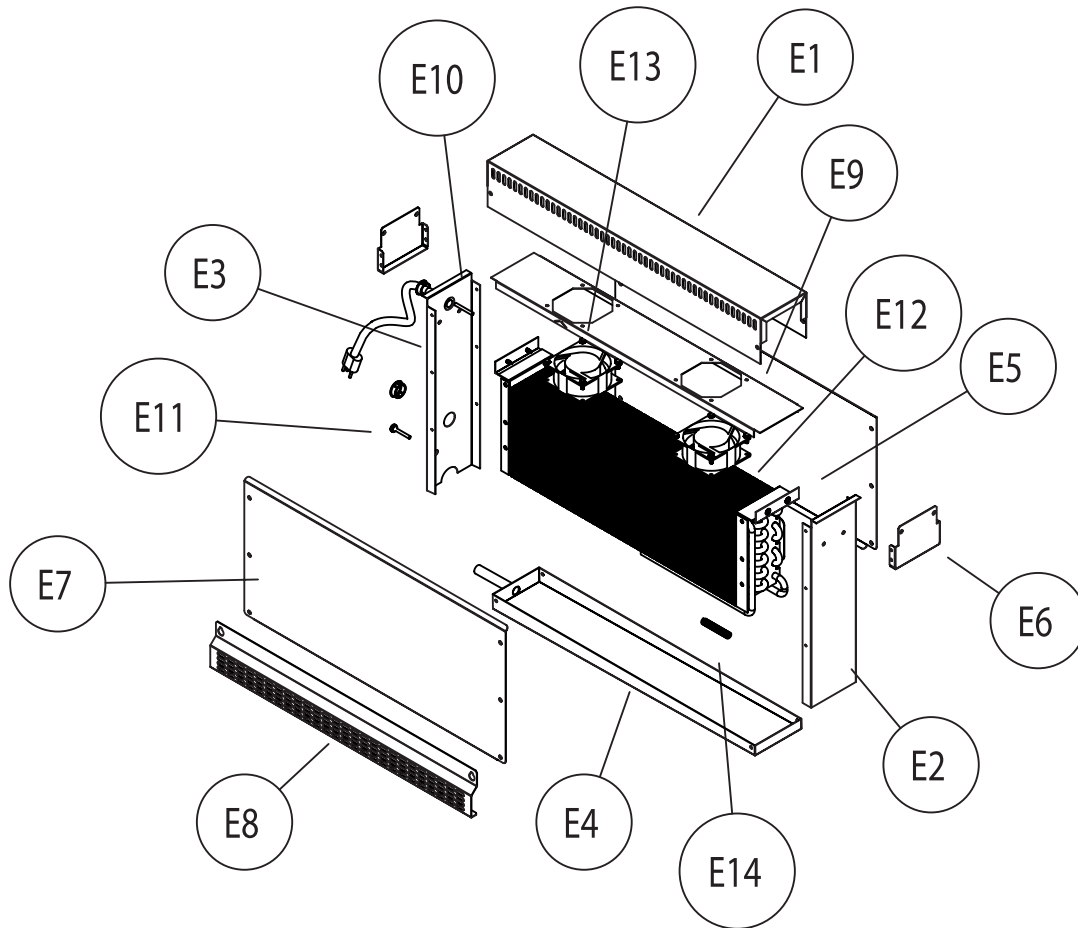

ITEM	SERVICE PART	DESCRIPTION	9215-290
E1	RP GRD2504	TOP, EVAP COIL, 9215-290	X
E2	RP FRT2511	FRONT, EVAP COIL, NARROW	X
E3	RP BCK2501	REAR, EVAP COIL, NARROW	X
E4	RP DRP2501	PAN, DRAIN	X
E5	RP GRD2102	BRACKET, EVAP MOUNTING	X
E6	RP GRD2503	BRACKET, COIL MOUNT	X
E7	RP CVR2501	SIDE, EVAP COIL HOUSING, NARROW	X
E8	RP GRD2502	GUARD, DRAIN PAN	X
E9	RP SHD2501	SHROUD, EVAP COIL, TWO FANS, NARROW	X
E10	RF CNT1602	THERMISTOR, COIL DEFROST, BLUE	X
E11	RF CNT1603	THERMISTOR, COIL AIR, BLACK	X
E12	RF COI125	4 X 7.5 X 21in MULLION COIL	X
E13	RF FAN2204	FAN, EVAPORATOR, 92mm x 38mm	X
E14	T07-2159	CAPILLARY TUBE, 0.044 X 0.093 CAP, 132in LONG, 3ft/7ft/11ft	X

## SR BOX2406

