

WEP-100P™

Effluent Pump



About

The WEP- 100P effluent pump is used to pump waste water that might be fed by gravity to a higher level or extended some distance with a horizontal pipe.

This system allows you to install machines that generate waste water in places where there may not be a grade level drain.

Designed, developed, and manufactured by Power Knot in Silicon Valley, California.

Features

- High reliability AC pump
- System operation is fully automatic
- Integrated electronic control
- Level detectors work with submersible solids to prevent clogging
- Pump is turned on only when required
- Quiet operation
- 3 color LED indicates operational status
- Sanitary fittings for input and output enable easy installation with standard plumbing connections
- Water exit is user configurable for back or side of tank
- Can accept a high flow rate of waste water and can accept an inrush of 75 litre (20 gallon) of waste water in under a second
- Input waste water can be as low as 50 mm (1.9") above the ground
- Tank is directly vented or can be easily piped to the outside
- Internal shut off valve prevents any possibility of overflow
- Relay contacts indicate an alarm to an external system there is no power, tank full, or a fault
- Waterproof construction ensures easy cleaning
- Pump is easily accessed for service or replacement

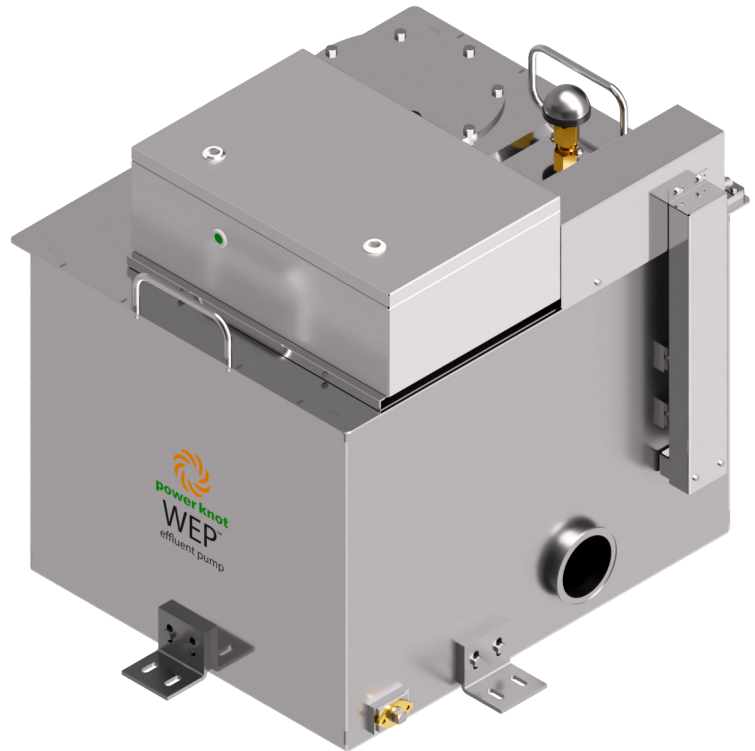

- Simple integration with Power Knot LFC and LCD biodigesters
- Supplied brackets permit bolting or welding to floor
- Manual drain allows emptying the tank for decommissioning
- Constructed of stainless steel with expected life of 15 to 25 years

Benefits

- Eliminates the need for a grade level drain or a drain near the source of the waste water
- Can be situated in kitchens and work areas
- User is alerted when there is a problem to minimize downtime
- Maintenance is accomplished by existing staff
- Universal ac power input ensures compatibility to operate globally
- Three year warranty¹

¹ Warranty is subject to terms and conditions.

WEP-100P

Description

Tank volume

143 litre (38 gallon) maximum

Construction

All stainless steel (chassis, control box, mounting brackets, and handle)

Operating environment

Indoors or outdoors

Operating temperature

4°C to 40°C (38°F to 104°F)

Operating altitude

1000 m (3300 ft)

Ingress protection

IP54 – splash proof and dust proof

Operating lifetime

Expected to be 15 to 25 years

Moving and positioning

Machine is moved in place using the two handles

Machine can be bolted or welded to the floor using the four supplied L brackets

Floor surface flatness

±1 mm (±0.05") maximum

Weight when empty

60 kg (132 lb)

Maximum weight when full

203 kg (448 lb)

Pump output position

Configured to be left side or rear. Installed at time of order, but can be user configured on site.

Pump flow rate

The flow rate is dependent on many factors including the output pressure as approximately shown by the red line in the figure below.

The WEP-100P effluent pump can pump water as high as 14 m (46 ft). This assumes the output pipe is 20 mm (¾") diameter and has no bends.

With no output pressure the flow rate can be as high as 5 m³/h (22 gpm), but this is usually not practical.

A horizontal pipe run of 10 m (33 ft) is equivalent to a head of approximately 4 m (13 ft).

The graph below and the comments above are for guidance only and subject to change without notice.

Breather

The breather is a ½" NPT fitting that allows air to egress when the tank is filling and to ingress when the tank is emptying.

The breather is fitted with a mesh filter and can be plumbed by the user elsewhere if desired.

Relay output

2 pin female SD13

Relay is normally closed to indicate to host system that it is ok to send water

Relay is open to indicate that host system should stop sending water when:

- there is no power to the WEP-100P pump
- tank has more than 117 litre (31 gallon)
- computer system has detected a fault

Water particle size

3 mm (0.1") maximum

Water temperature

4°C to 50°C (39°F to 122°F)

Controls and Indications

LED: 22 mm 3-colors

Current meter: reads motor current

Push button: manual pump on

Audio beeper to indicate error condition

AC supply (order one type)

110 V: 95 V to 125 V, 50 Hz to 60 Hz

Single phase + PE

External circuit breaker: 12 A

AC power cord

Length of cable on machine: 1.8 m

Can wire directly (without a plug and socket). Outlet must be accessible by operator and have a safety disconnect.

Maximum power

750 W

Energy per day

3.5 kWh (typical)

18 kWh (maximum)

Warranty

One year on pump; three years on all other parts

EU directives

Low Voltage Directive: 2014 / 35 / EU

EMC Directive: 2014 / 30 / EU

RoHS Directive: 2011 / 65 / EC

WEEE Directive: 2012 / 19 / EC

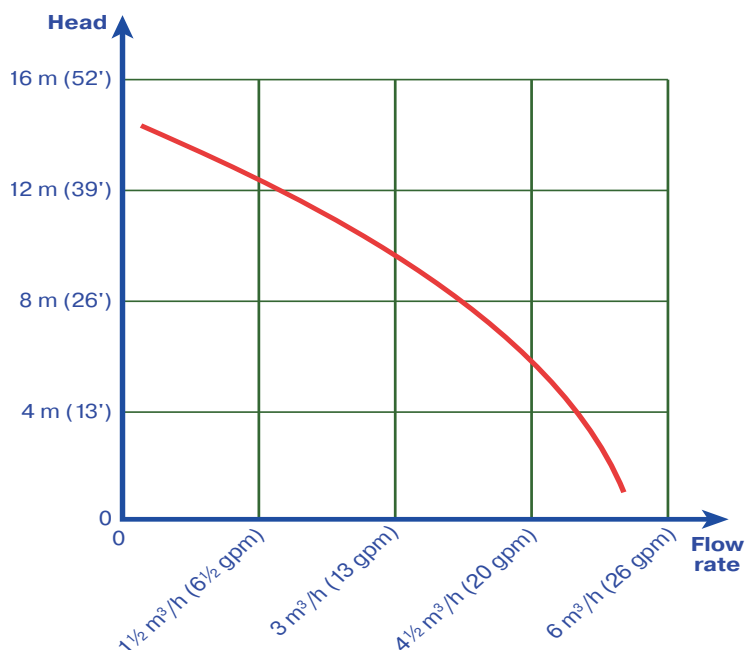

WEP-100P

Dimensions in mm ±2 mm

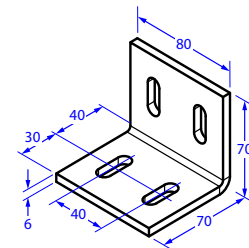
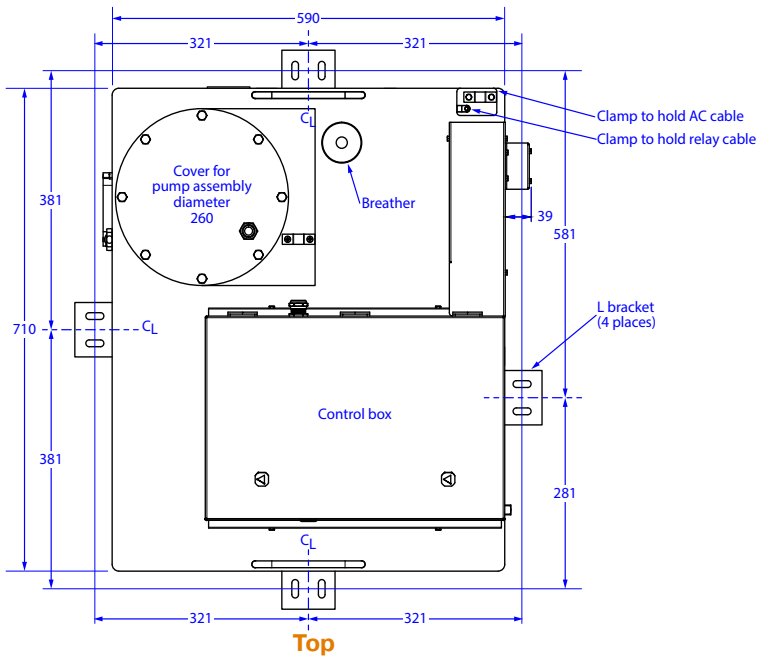
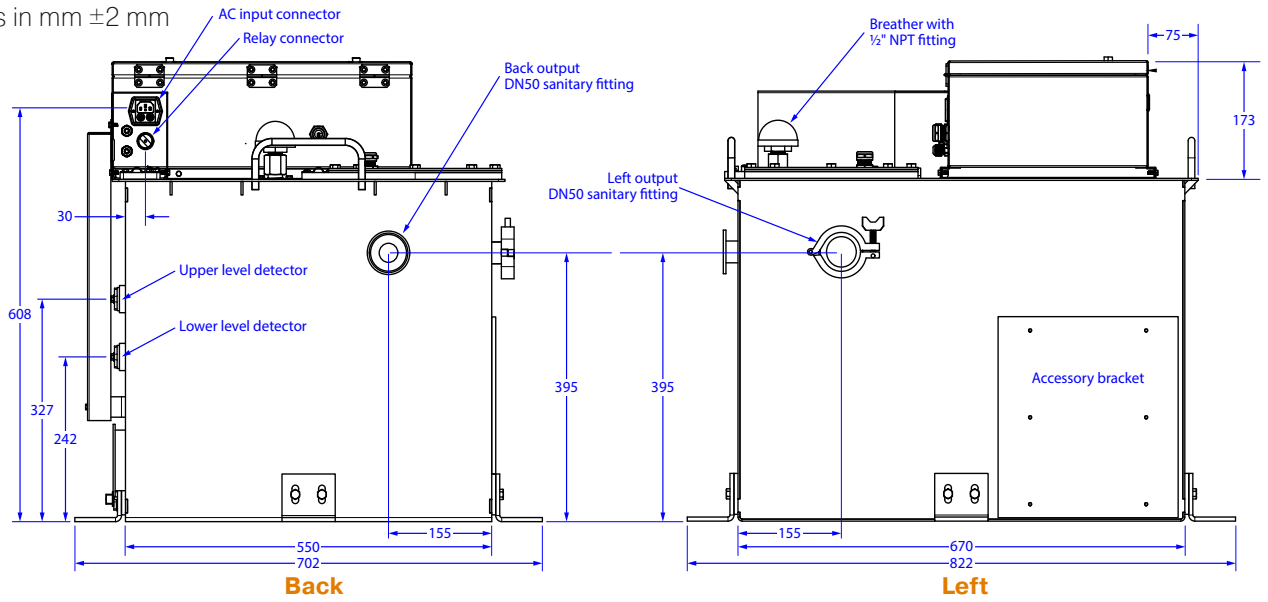

Use M8x10 bolt with flat washer

Detail of L bracket

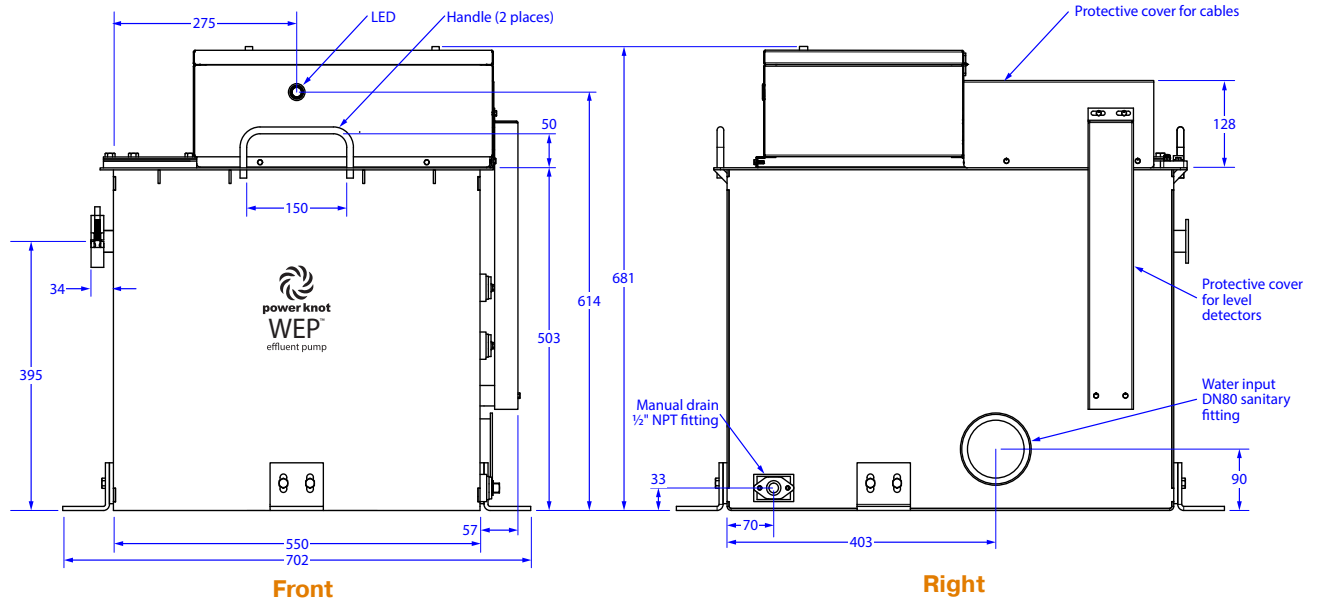

WEP-100P

Dimensions in inches ±0.1"
(derived from mm)

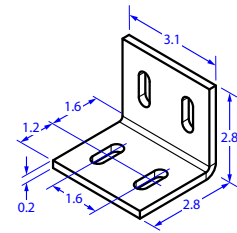
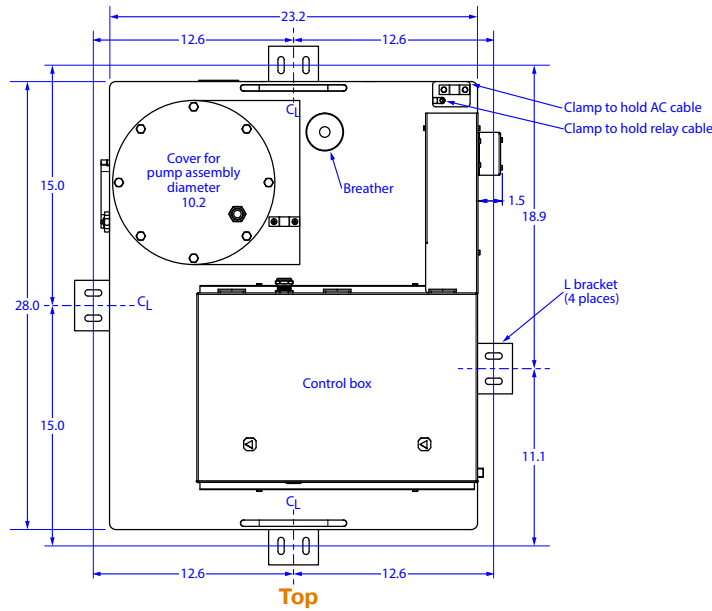
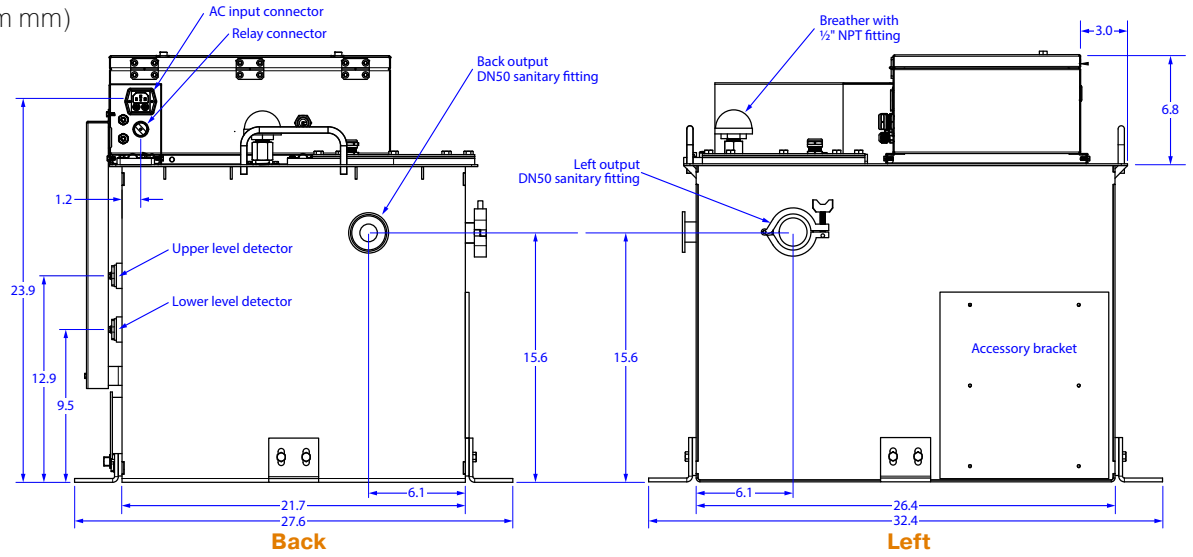

Use M8x10 bolt with flat washer
Detail of L bracket

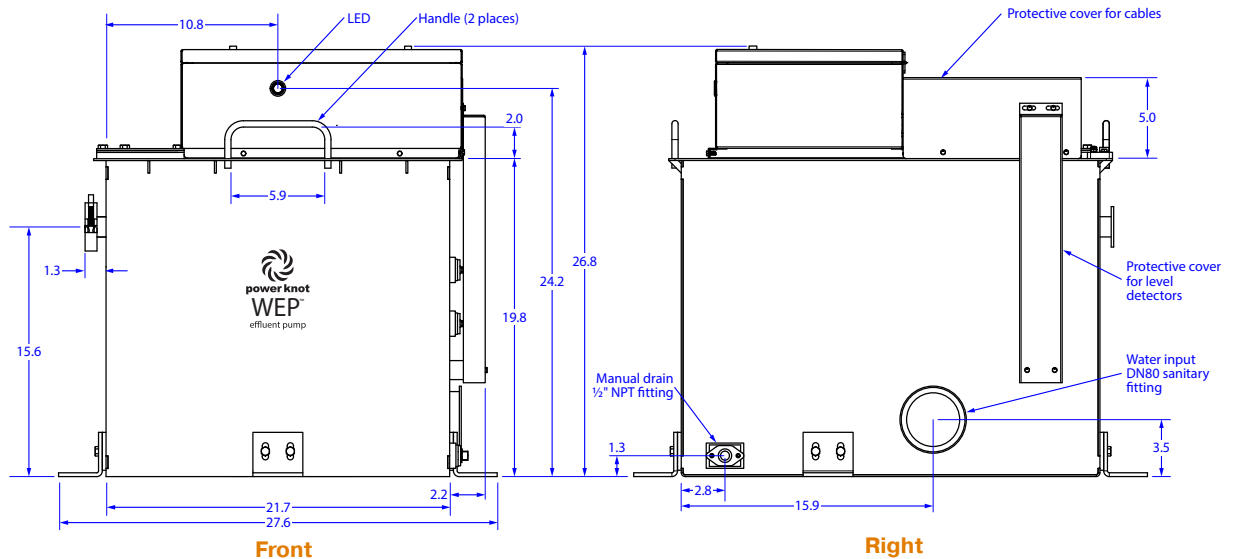

Power Knot LLC | 47613 Warm Springs Blvd | Fremont, CA 94539 USA | +1-408-889-8433 | info@powerknot.com | www.powerknot.com

Power Knot, the Power Knot logo, the Power Knot mark, LCD, LFC, and WEP are trademarks or registered trademarks of Power Knot LLC. All other trademarks used herein are the property of their respective owners. Copyright © 2018–2024 Power Knot LLC; all rights are reserved. Specifications are subject to change at any time without notice. Document number 96-01149-07, 27 January 2024.