

LFC-100FT

Biodigester

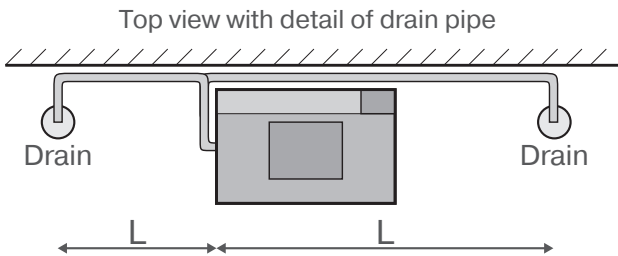

Only one drain is required on left side or right side of machine
Pipes normally run along wall for neatness, but can be direct
L = length of pipe run: 400 cm (160") maximum; 3 of 90° bends maximum; do not run pipes under the biodigester

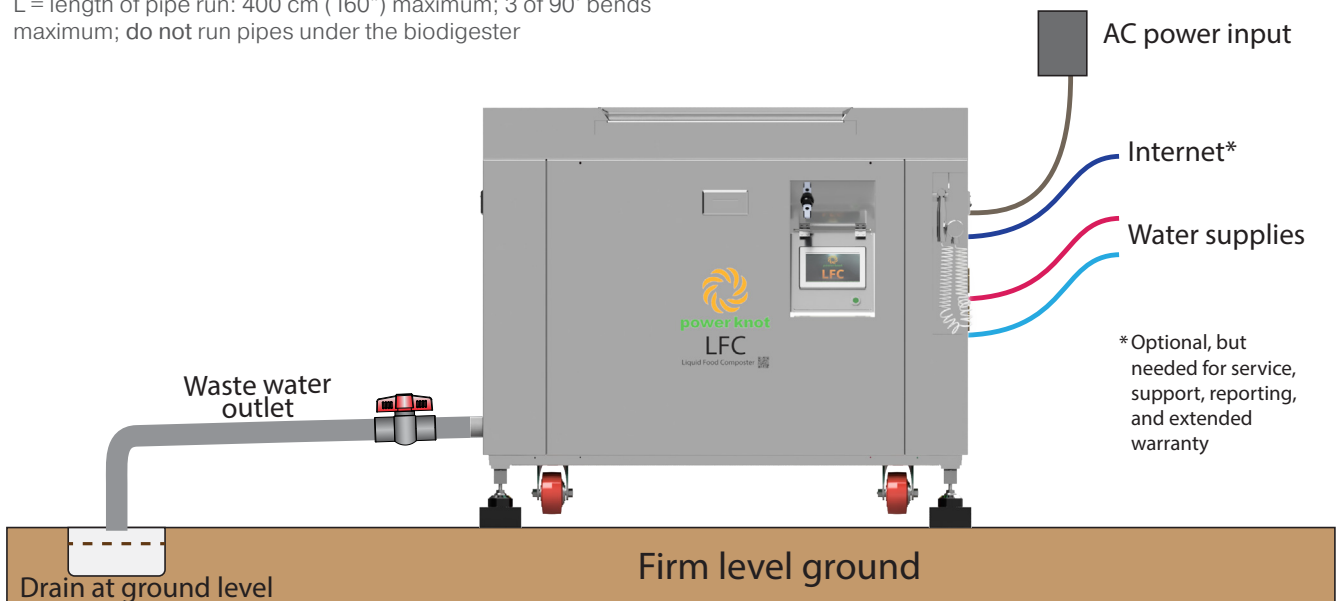

LFC-100FT

Installation Requirements

Maximum capacity of food waste

100 kg (220 lb)
125 litre (32 gallon)

Digestion of food waste per day

35–300 kg (80–660 lb)

Construction

All stainless steel (chassis, side panels, drum, shaft, arms, paddles, and load cells). Chassis is mirror finish (EN 10088-2 specification 2P)

Operating environment

Indoors or covered patio

Must not be exposed to rain, snow, or sunshine

Ingress protection

IP54 – splash proof and dust proof

Operating altitude

0~3000 m (9800 ft)

Ambient operating temperature

4°C~38°C (39°F~100°F) when altitude is less than 1000 m (3300 ft); reduce linearly to 24°C (75°F) at 3000 m

Floor surface flatness required

±15 mm (0.6")

Weight when empty

305 kg (673 lb)

Moving and positioning

Machine is rolled into place with casters

Machine is raised once in position and supported by feet and rubber pads

Weight when full

475 kg (1047 lb) maximum

Load per pad

158 kg (349 lb) maximum

Pressure per pad

155 kPa (23 psi), maximum

Space required around machine

Left side: 20 cm (8") minimum, 33 cm (13") ideal. 100 cm (39") is required for servicing

Right side: 15 cm (6") minimum, 60 cm (24") preferred. 125 cm (50") is required for servicing

Back: 2 cm (1")

Front: 60 cm (24") minimum

Water inlets

Filters: use external filters to remove particles and hardness

Fitting: DN15 (½") female

Use flexible hose pipes to allow machine to move freely. Install valves to disconnect water for servicing and backflow prevention devices if required

Pressure: 275 to 550 kPa (40 to 80 psi, 2.8 to 5.6 kg/cm²)

Flow rate: 20 litre per minute (5 gpm) max. @ 450 kPa (65 psi, 4.5 kg/cm²)

Drum water: 35°C~50°C (95°F~120°F)

Washout water: 15°C~75°C (60°F~165°F)

Use external mixing valves, heaters, pressure reducers, and bladder tanks to meet the above requirements as needed

Water input per day

300 litre (79 gallon) typical

Water outlet

Typically use flexible coupling on output to permit machine to move freely

Install stop valve on outlet pipe (used for commissioning)

Slope pipe down by about 1 in 45 (1.3°)

Drain

Type: Must exit to sewer (not storm drain); grease trap is required in most jurisdictions

Size: 65 mm (2½") minimum

Total water output per day

400 litre (106 gallon), typical

Flow rate of waste water out

21 l/min (5.4 gpm), maximum
0.3 l/min (0.1 gpm), typical average

AC supply

120 V, 60 Hz (100 V to 130 V)

Single phase + PE

Circuit breaker: 15 A

Fitted with NEMA 5-15 plug

or

230 V, 50 Hz (220 V to 240 V)

Single phase + PE

Circuit breaker: 15 A

Plug installed by local distributor

AC power cord

Length of cable on machine: 180 cm (6')

Can wire directly (without a plug and socket). Outlet must be accessible by operator and have a safety disconnect

Maximum power

850 W

Electrical energy per day

5.7 kWh typical

Heat generated by digestion

100 W ~ 400 W, 200 W typical

User interface

22 mm 3-color LED

125 mm (5") touchscreen with 65k colors

Ethernet

RJ45, 100 baseT

DHCP or fixed IP address

Connect to Internet with direct cable, Wi-Fi client, or GSM modem

Automatically connects to LFC Cloud for remote support, reporting, and monitoring (included in purchase price)

Powerzyme

Microorganisms and enzymes

1 litre, included with initial purchase

Powerchips

Medium for microorganisms

100 litre, included with initial purchase

Operating lifetime

Expected to be 15 to 25 years

Warranty

3 years on all parts and components (1 year for marine, security, and rentals)
Subject to terms and conditions

Safety

Certified to UL430 edition 8

(waste disposal machines)

CAN/CSA-C22.2 No. 60335-1:11 R16

CAN/CSA-C22.2 No. 60335-2-16:16

EN 60335-1:2012+A11:2014+A13:2017

+A1:2019+ A14:2019+A2:2019

EN 60335-2-16:2003+A1:2008+A2:2012

+A11:2018

EMC and EMI

47 CFR FCC part 15, subpart B, class B

ICES-003:2016 Issue 6, class B

ANSI C63.4:2014

EN 61000-6-1:2007 & 2005

EN 61000-6-3:2007+A1:2011 & 2006

CISPR 16-2-3:2016

CISPR 16-2-1:2006

CISPR 16-1-2:2003 + A1:2004 + A2:2006

EN 61000-3-2:2005 +A1:2008 +A2:2009

EN 61000-3-3:2013

EN 61000-4-2:1995

EN 61000-4-3:2006

EN 61000-4-4:2004

EN 61000-4-5:2006

EN 61000-4-6:2014

EN 61000-4-8:1993

EN 61000-4-11:2004

EU directives

Low Voltage Directive: 2014 / 35 / EU

EMC Directive: 2014 / 30 / EU

RoHS Directive: 2011 / 65 / EC

WEEE Directive: 2012 / 19 / EC



For complete details see User's Manual

LFC-100FT

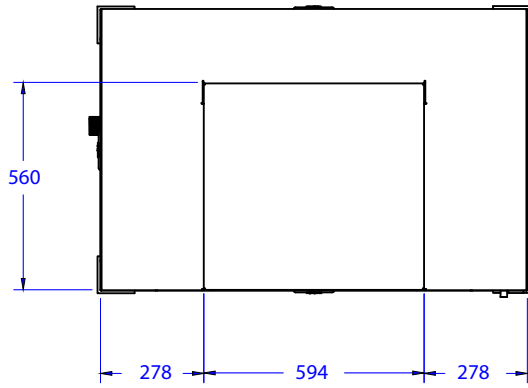

Top

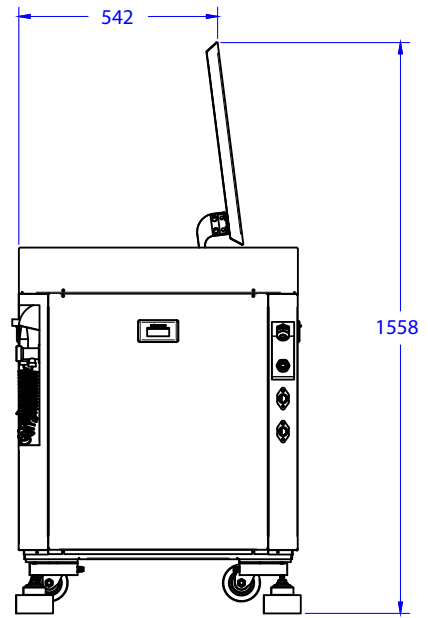

Right with door fully open

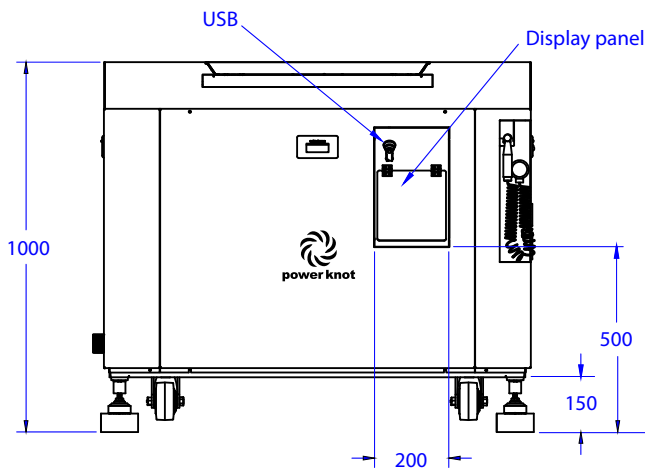

Front

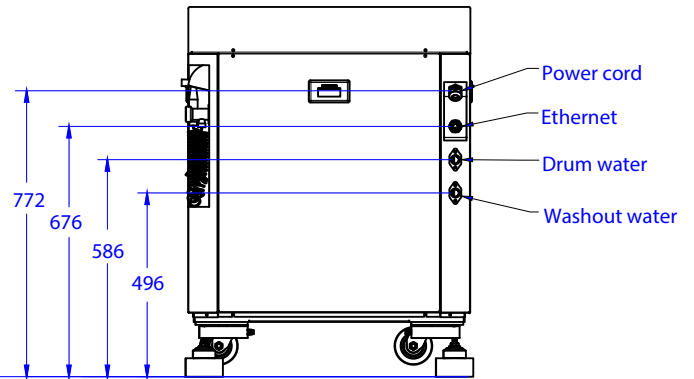

Right

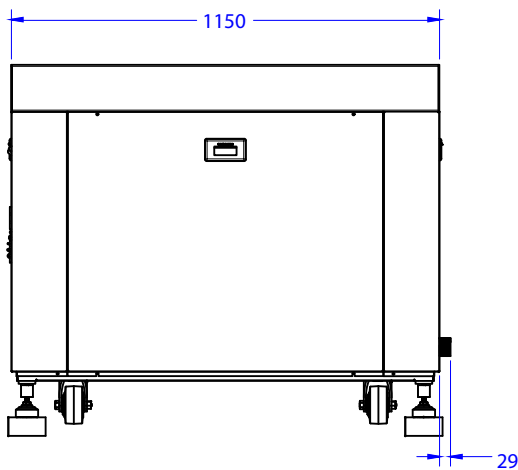

Back

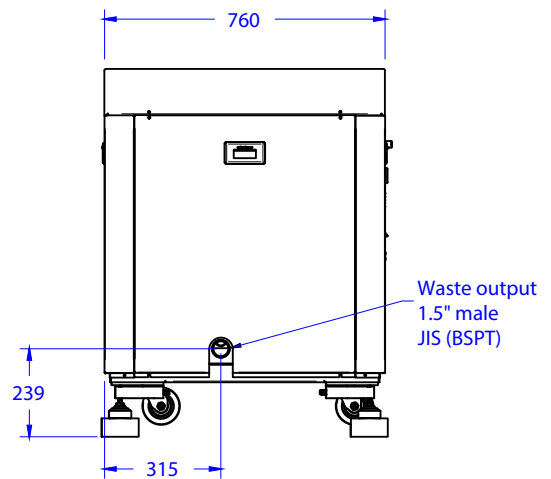

Left

LFC-100FT

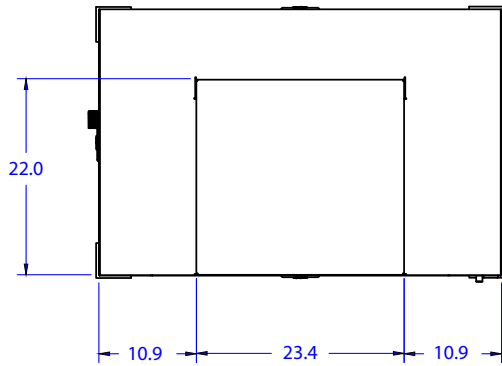

Top

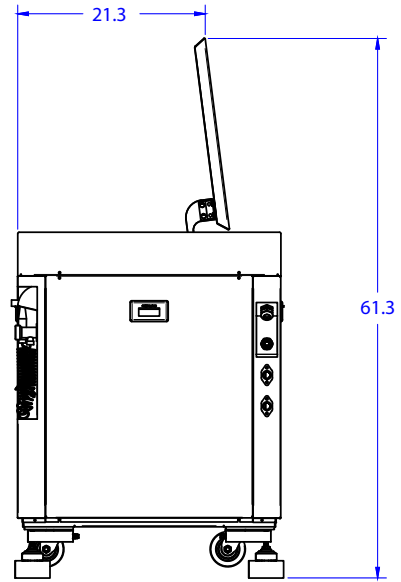

Right with door fully open

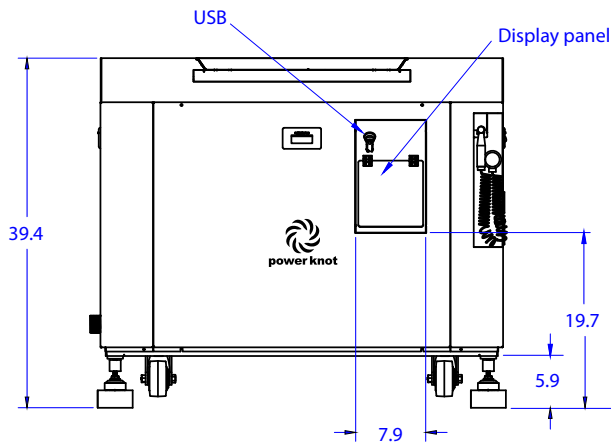

Front

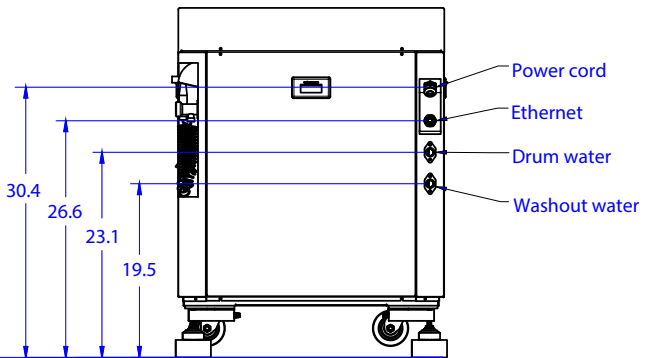

Right

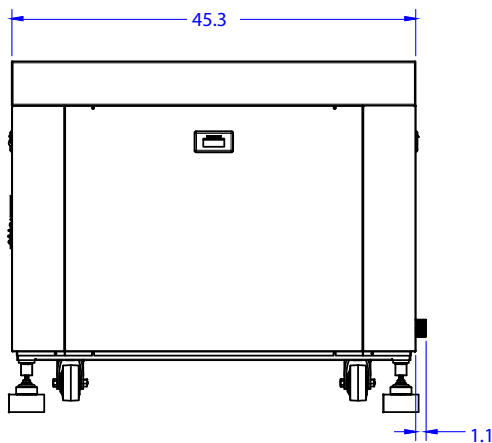

Back

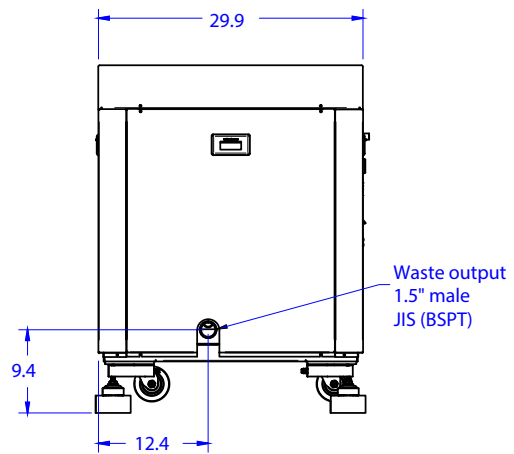

Left



Power Knot LLC | 47613 Warm Springs Blvd | Fremont, CA 94539 USA | +1-408-889-8433 | info@powerknot.com | www.powerknot.com

Power Knot, the Power Knot logo, the Power Knot mark, LFC, and LFC Cloud are trademarks or registered trademarks of Power Knot LLC. All other trademarks used herein are the property of their respective owners. Copyright © 2009–2021 Power Knot LLC; all rights are reserved. Specifications are subject to change at any time without notice. Document number 96-01065-22, 30 October 2021.