



**FOOD EQUIPMENT**

**SERVING THE FOOD INDUSTRY SINCE 1951**

# ELITE SERIES ELECTRIC COUNTERTOP SINGLE BASKET DEEP FRYERS

Items: 47281, 47282 | Model: CE-CN-0401, CE-CN-0402

**OMCAN'S ELITE SERIES COUNTERTOP DEEP FRYERS ARE PERFECT FOR SAVING SPACE AND SMALL TO MEDIUM APPLICATIONS**



**WARRANTY**  
PARTS AND LABOR



Authorized Dealer

### TECHNICAL DRAWINGS & DIMENSIONS

\*measurements in diagrams are in mm

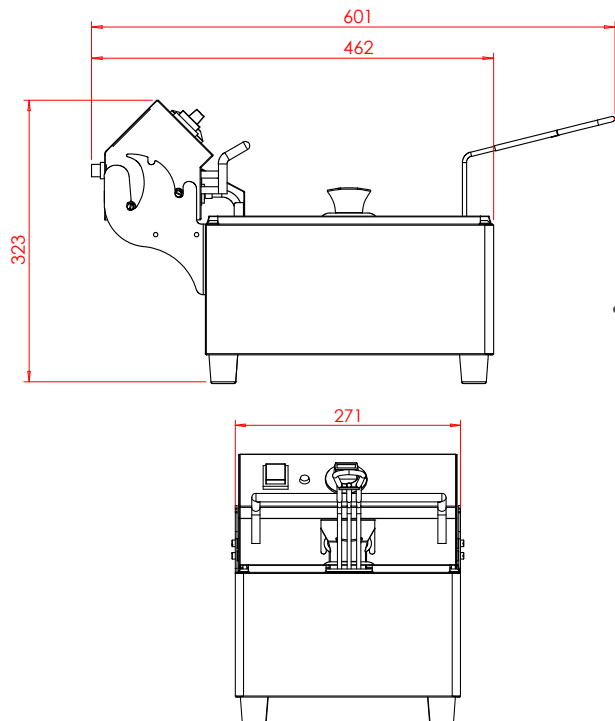

### TECHNICAL SPECIFICATIONS

#### Elite Series 10 lbs Capacity Electric Countertop Single Basket Deep Fryer

Item	47281
Model	CE-CN-0401
Electrical	120V / 60Hz / 1 Ph
Power	1.8 kW
Number of Fryer Baskets	1 (1 included)
Oil Capacity	10 lbs   4.5 kg
Temperature Range	175 - 390 °F   79.4 - 198.9 °C
Weight	14.3 lbs   6.5 kg
Gross Weight	18.1 lbs   8.2 kg
Basket Dimensions	Single Basket: 8.1" x 7.9" x 4.5"
Dimensions (WDH)	10.7" x 18.2" x 12.7"
Gross Dimensions	22" x 13.8" x 16.9"

### FEATURES:

- Ideal for small to medium applications
- Stainless steel
- Controlled by thermostat
- Thermostat control valves
- Temperature Range: 79.4 – 198.9 °C (175 – 390 °F)
- Comes with a fryer basket and lid

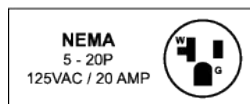

## OMCAN INC.

Telephone: 1-800-465-0234  
 Fax: (905) 607-0234  
 Email: sales@omcan.com  
 Website: www.omcan.com



Follow us to keep up to date with the latest news and offers



### TECHNICAL DRAWINGS & DIMENSIONS

\*measurements in diagrams are in mm

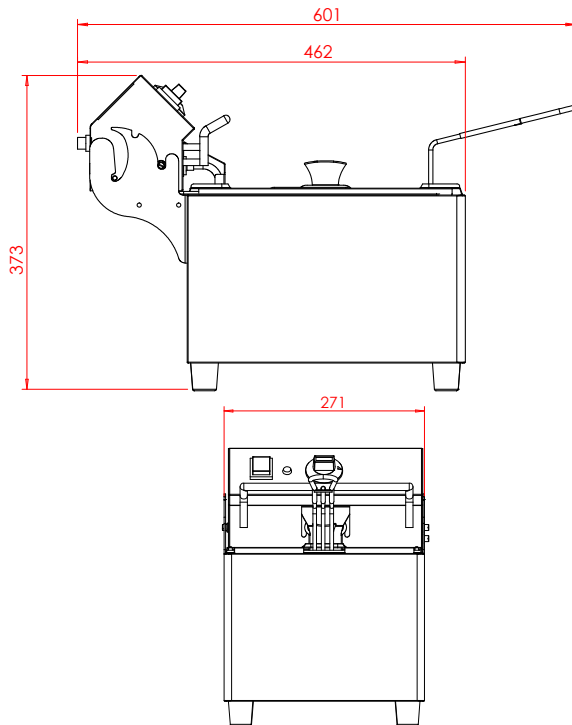

### TECHNICAL SPECIFICATIONS

#### Elite Series 15 lbs Capacity Electric Countertop Single Basket Deep Fryer

<b>Item</b>	47282
<b>Model</b>	CE-CN-0402
<b>Electrical</b>	220V / 60Hz / 1 Ph
<b>Power</b>	3.6 kW
<b>Number of Fryer Baskets</b>	1 (1 included)
<b>Oil Capacity</b>	15 lbs   6.8 kg
<b>Temperature Range</b>	175 - 390°F   79.4 - 198.9°C
<b>Weight</b>	17 lbs   7.7 kg
<b>Gross Weight</b>	20.9 lbs   9.5 kg
<b>Basket Dimensions</b>	Single Basket: 8.1" x 7.9" x 5.5"
<b>Dimensions (WDH)</b>	10.7" x 18.2" x 14.7"
<b>Gross Dimensions</b>	22" x 13.8" x 18.9"

### FEATURES:

- Ideal for small to medium applications
- Stainless steel
- Controlled by thermostat
- Thermostat control valves
- Temperature Range: 79.4 – 198.9°C (175 – 390°F)
- Comes with a fryer basket and lid

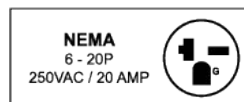

## OMCAN INC.

Telephone: 1-800-465-0234  
 Fax: (905) 607-0234  
 Email: sales@omcan.com  
 Website: www.omcan.com



Follow us to keep up to date with the latest news and offers

