



Refrigerated Showcases

Models RS-CN-0271, 0271-S, 0371, 0371-S, 0471, 0471-S, 0571, 0571-S

Items 44387, 44382, 44502, 44383, 44503, 44384, 44504, 44505

Instruction Manual



STOP
DO NOT RETURN
THIS PRODUCT TO THE STORE

For questions or assistance with this product call OMCAN Toll Free: 1 800 465 0234
Customer Service
or
visit the Support section of www.omcan.com

Revised - 09/10/2025

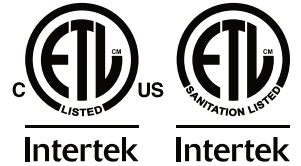

Toll Free: 1-800-465-0234
Fax: 905-607-0234
Email: service@omcan.com
www.omcan.com



Table of Contents

Model RS-CN-0271 / Model RS-CN-0271-S / Model RS-CN-0371
Model RS-CN-0371-S / Model RS-CN-0471 / Model RS-CN-0471-S
Model RS-CN-0571 / Model RS-CN-0571-S

Section	Page
Disclaimer -----	3
General Information -----	4 - 5
Safety and Warranty -----	5 - 8
Technical Specifications -----	8 - 11
Operation -----	11 - 12
Maintenance -----	13
Troubleshooting -----	13
Parts Breakdown -----	14 - 29
Electrical Schematics -----	30 - 32
Notes -----	33 - 34
Warranty Registration -----	35

OMCAN IS NOT RESPONSIBLE FOR ANY DAMAGES DUE TO WATER LEAKS. WARRANTY FOR WATER LEAKS IS VOID IF THE AMBIENT ROOM TEMPERATURE EXCEEDS 75°F AND 55% RELATIVE HUMIDITY, AND THE APPLIANCE DRAIN IS NOT CONNECTED DIRECTLY TO A FLOOR DRAIN.

OMCAN N'EST PAS RESPONSABLE DES DOMMAGES DUS AUX FUITES D'EAU. LA GARANTIE POUR LES FUITES D'EAU EST ANNULÉE SI LA TEMPÉRATURE AMBIANTE DE LA PIÈCE DÉPASSE 75°F ET 55% D'HUMIDITÉ RELATIVE, ET SI LE DRAIN DE L'APPAREIL N'EST PAS RACCORDÉ DIRECTEMENT À UN DRAIN DE PLANCHER.

OMCAN NO SE HACE RESPONSABLE DE LOS DAÑOS CAUSADOS POR FUGAS DE AGUA. LA GARANTÍA POR FUGAS DE AGUA QUEDA ANULADA SI LA TEMPERATURA AMBIENTE SUPERA LOS 75°F Y EL 55% DE HUMEDAD RELATIVA, Y EL DESAGÜE DEL APARATO NO ESTÁ CONECTADO DIRECTAMENTE A UN DESAGÜE DE PISO.

General Information

Omcan Manufacturing and Distributing Company Inc., Food Machinery of America, Inc. dba Omcan and Omcan Inc. are not responsible for any harm or injury caused due to any person's improper or negligent use of this equipment. The product shall only be operated by someone over the age of 18, of sound mind, and not under the influence of any drugs or alcohol, who has been trained in the correct operation of this machine, and is wearing authorized, proper safety clothing. Any modification to the machine voids any warranty, and may cause harm to individuals using the machine or in the vicinity of the machine while in operation.

CHECK PACKAGE UPON ARRIVAL

Upon receipt of an Omcan shipment please inspect for external damage. If no damage is evident on the external packaging, open carton to ensure all ordered items are within the box, and there is no concealed damage to the machine. If the package has suffered rough handling, bumps or damage (visible or concealed), please note it on the bill of lading before accepting the delivery and contact Omcan within 24 hours, so we may initiate a claim with the carrier. A detailed report on the extent of the damage caused to the machine must be filled out within three days, from the delivery date shown in the shipping documents. Omcan has no recourse for damaged products that were shipped collect or third party.

Before operating any equipment, always read and familiarize yourself with all operation and safety instructions.

Omcan would like to thank you for purchasing this machine. It's of the utmost importance to save these instructions for future reference. Also save the original box and packaging for shipping the equipment if servicing or returning of the machine is required.

Omcan Fabrication et distribution Compagnie Limitée et Food Machinery d'Amérique, dba Omcan et Omcan Inc. ne sont pas responsables de tout dommage ou blessure causé du fait que toute personne ait utilisé cet équipement de façon irrégulière. Le produit ne doit être exploité que par quelqu'un de plus de 18 ans, saine d'esprit, et pas sous l'influence d'une drogue ou d'alcool, qui a été formé pour utiliser cette machine correctement, et est vêtu de vêtements de sécurité appropriés. Toute modification de la machine annule toute garantie, et peut causer un préjudice à des personnes utilisant la machine ou des personnes à proximité de la machine pendant son fonctionnement.

VÉRIFIEZ LE COLIS DÈS RÉCEPTION

Dès réception d'une expédition d'Omcan veuillez inspecter pour dommages externes. Si aucun dommage n'est visible sur l'emballage externe, ouvrez le carton afin de s'assurer que tous les éléments commandés sont dans la boîte, et il n'y a aucun dommage dissimulé à la machine. Si le colis n'a subi aucune mauvaises manipulations, de bosses ou de dommages (visible ou cachée), notez-le sur le bond de livraison avant d'accepter la livraison et contactez Omcan dans les 24 heures qui suivent, pour que nous puissions engager une réclamation auprès du transporteur. Un rapport détaillé sur l'étendue des dommages causés à la machine doit être rempli dans un délai de trois jours, à compter de la date de livraison indiquée dans les documents d'expédition. Omcan n'a aucun droit de recours pour les produits endommagés qui ont été expédiés ou cueillis par un tiers transporteur.

Avant d'utiliser n'importe quel équipement, toujours lire et vous familiariser avec toutes les opérations et les

General Information

consignes de sécurité.

Omcan voudrais vous remercier d'avoir choisi cette machine. Il est primordial de conserver ces instructions pour une référence ultérieure. Également conservez la boîte originale et l'emballage pour l'expédition de l'équipement si l'entretien ou le retour de la machine est nécessaire.

Omcan Empresa De Fabricacion Y Distribucion Inc. Y Maquinaria De Alimentos De America, Inc. dba Omcan y Omcan Inc. no son responsables de ningun daño o perjuicio causado por cualquier persona inadecuada o el uso descuidado de este equipo. El producto solo podra ser operado por una persona mayor de 18 años, en su sano juicio y no bajo alguna influencia de droga o alcohol, y que este ha sido entrenado en el correcto funcionamiento de esta máquina, y ésta usando ropa apropiada y autorizada. Cualquier modificación a la máquina anula la garantía y puede causar daños a las personas usando la máquina mientras esta en el funcionamiento.

REVISE EL PAQUETE A SU LLEGADA

Tras la recepcion de un envio Omcan favor inspeccionar daños externos. Si no hay daños evidentes en el empaque exterior, Habra el carton para asegurarse que todos los articulos solicitados estén dentro de la caja y no encuentre daños ocultos en la máquina. Si el paquete ha sufrido un manejo de poco cuidado, golpes o daños (visible o oculto) por favor anote en la factura antes de aceptar la entrega y contacte Omcan dentro de las 24 horas, de modo que podamos iniciar una reclamación con la compañía. Un informe detallado sobre los daños causados a la máquina debe ser llenado en el plazo de tres días, desde la fecha de entrega que se muestra en los documentos de envío. Omcan no tiene ningun recurso por productos dañados que se enviaron a recoger por terceros.

Antes de utilizar cualquier equipo, siempre lea y familiarizarse con todas las instrucciones de funcionamiento y seguridad.

Omcan le gustaría darle las gracias por la compra de esta máquina. Es de la mayor importancia para salvar estas instrucciones para futuras consultas. Además, guarda la caja original y el embalaje para el envío del equipo si servicio técnico o devolución de la máquina que se requiere.

Safety and Warranty

HANDLE AND ASSEMBLING



Handle with care

Unplug wall socket before moving. Never tilt the refrigerator over 45 degrees during handling.

Safety and Warranty



Storage
Always store refrigerator in a dry place.

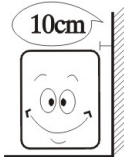

Sufficient space
To allow for proper air circulation and increased refrigeration capabilities, the refrigerator must have at least 3 inches of space between wall and unit.

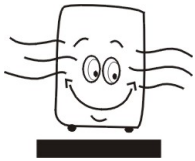

Proper ventilation
Always place the refrigerator in an area with good ventilation. For first time use, wait at least 2 hours before plugging into wall socket.

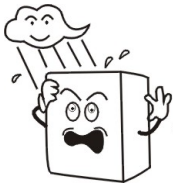

Away from heat source
Never place the refrigerator near any type of heat source or in direct sunlight, as it reduces refrigeration capabilities.



No heavy load
Never put heavy items on top of the refrigerator.

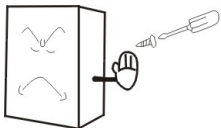

No alterations/tampering
Never tamper with, or make changes to the refrigerator. Changes and add-ons should not be installed to the inside or outside of the refrigerator.

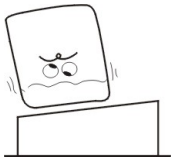

Stable location
Unpack and place the refrigerator on flat, solid ground.

PREPARATION AND POWER SUPPLY

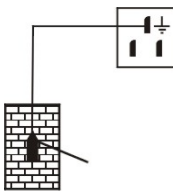

Power receptacle



Ground

Exclusive power socket

Power supply should be 110-120V, single phase AC with exclusive single phase three pin outlet and fuse (8A). The power outlet must be in close proximity to the ground.

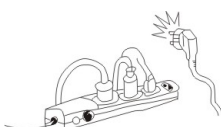

No shared power outlets

Refrigerator cable should never share the power outlet with any other appliance, as cable will overheat and may result in a fire.

Safety and Warranty

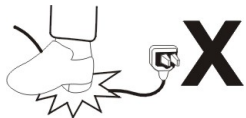

Protect cables

Extra caution should be used when handling cables, as broken or damaged cables can cause sparking and may result in a fire.



No water flushing

Never flush the refrigerator surface. This can cause leakage, which may result in electrical damage or fire.



Never store flammables and explosives

No explosives or flammables should be stored in, or in proximity to, the refrigerator, such as gasoline, alcohol, and adhesives.

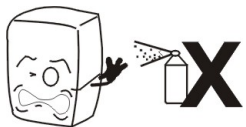

No spray

Never spray flammables such as paint or coating near the refrigerator. This may cause fire or malfunction.



After power outage

After a power outage or the unplugging of the refrigerator, wait at least 5 minutes before plugging it back in.



No medicine

Medicine should not be stored inside of the refrigerator.

RESIDENTIAL USERS: vendor assumes no liability for parts or labor coverage for component failure or other damages resulting from installation in non-commercial or residential applications. The right is reserved to deny shipment for residential usage; if this occurs, you will be notified as soon as possible.

2 YEARS PARTS AND LABOUR & 5 YEARS PARTS ONLY ON COMPRESSOR WARRANTY

Within the warranty period, contact Omcan Inc. at 1-800-465-0234 to schedule an Omcan authorized service technician to repair the equipment locally.

Unauthorized maintenance will void the warranty. Warranty covers electrical and part failures, not improper use.

Please see <https://omcan.com/disclaimer> for complete info.

WARNING:

The packaging components are classified as normal solid urban waste and can therefore be disposed of

Safety and Warranty

without difficulty.

In any case, for suitable recycling, we suggest disposing of the products separately (differentiated waste) according to the current norms.

DO NOT DISCARD ANY PACKAGING MATERIALS IN THE ENVIRONMENT!

Technical Specifications

0271 UNITS

Model	RS-CN-0271	RS-CN-0271-S
Item Number	44387	44382
Power	600 W	
Capacity	310 L / 10.95 cu.ft.	390 L / 13.77 cu.ft.
Lamp Power	23 W	
Temperature Range	0 - 12°C / 32 - 54°F	
Max Ambient Temp Rating	24°C / 75°F	
Refrigerant	R290	
Blowing Gas	Front	
Type of Climate	4	
Rated Current	7.1A	
Shelf Size	36.8" x 12" / 935 x 311mm 36.8" x 14" / 935 x 361mm	
Dimensions	36.4" x 26.8" x 55.9" / 925 x 680 x 1420mm	36.4" x 26.8" x 55.2" / 925 x 680 x 1403mm
Packaging Dimensions	39.4" x 29.3" x 57.9" / 1000 x 743 x 1470mm	
Weight	322 lbs. / 146 kgs.	357.1 lbs. / 162 kgs.
Packaging Weight	418.9 lbs. / 190 kgs.	451.9 lbs. / 205 kgs.



Technical Specifications

0371 UNITS

Model	RS-CN-0371	RS-CN-0371-S
Item Number	44502	44383
Power	620 W	
Capacity	420 L / 14.83 cu.ft	530 L / 18.71 cu.ft.
Lamp Power	38 W	
Temperature Range	0 - 12°C / 32 - 54°F	
Max Ambient Temp Rating	24°C / 75°F	
Refrigerant	R290	
Blowing Gas	Front	
Type of Climate	4	
Rated Current	7.4A	
Shelf Size	48.6" x 10" / 1235 x 261mm 48.6" x 14.4" / 1235 x 311mm 48.6" x 14.6" / 1235 x 371mm	44.7" x 12.2" / 1135 x 311mm 44.7" x 14.6" / 1135 x 371mm
Dimensions	48.2" x 26.8" x 56" 1225 x 680 x 1420mm	48.2" x 26.8" x 55.2" 1225 x 680 x 1403mm
Packaging Dimensions	39.4" x 29.3" x 57.9" / 1000 x 743 x 1470mm	
Weight	390.2 lbs. / 177 kgs.	429.9 lbs. / 195 kgs.
Packaging Weight	500.4 lbs. / 227 kgs.	504.9 lbs. / 229 kgs.

Technical Specifications

0471 UNITS

Model	RS-CN-0471	RS-CN-0471-S
Item Number	44503	44384
Power	605 W	
Capacity	535 L / 18.89 cu.ft.	670 L / 23.66 cu.ft.
Lamp Power	50 W	
Temperature Range	0 - 12°C / 32 - 54°F	
Max Ambient Temp Rating	24°C / 75°F	
Refrigerant	R290	
Blowing Gas	Front	
Type of Climate	4	
Rated Current	7.1A	
Shelf Size	55.7" x 10" / 1416 x 253mm 55.7" x 14.4" / 1416 x 367mm	55.5" x 12" / 1412 x 311mm 55.5" x 14.6" / 1412 x 371mm
Dimensions	60" x 26.8" x 56" / 1525 x 680 x 1420mm	60" x 26.8" x 55.2" / 1525 x 680 x 1403mm
Packaging Dimensions	63" x 29.3" x 57.9" / 1600 x 743 x 1470mm	
Weight	463 lbs. / 210 kgs.	505 lbs. / 229 kgs.
Packaging Weight	542.3 lbs. / 246 kgs.	556 lbs. / 252 kgs.

Technical Specifications

0571 UNITS

Model	RS-CN-0571	RS-CN-0571-S
Item Number	44504	44505
Power	625 W	
Capacity	650 L / 22.95 cu.ft.	810 L / 28.61 cu.ft.
Lamp Power	60 W	
Temperature Range	0 - 12°C / 32 - 54°F	
Max Ambient Temp Rating	24°C / 75°F	
Refrigerant	R290	
Blowing Gas	Front	
Type of Climate	4	
Rated Current	7.7A	
Shelf Size	33" x 10" / 843 x 253mm 33" x 14" / 843 x 367mm	37" x 12" / 942 x 311mm 37" x 14" / 942 x 361mm
Dimensions	71.9" x 26.8" x 56" 1825 x 680 x 1420mm	71.9" x 26.8" x 55.2" 1825 x 680 x 1403mm
Packaging Dimensions	74.8" x 29.3" x 57.9" / 1900 x 743 x 1470mm	
Weight	518 lbs. / 235 kgs.	540.1 lbs. / 245 kgs.
Packaging Weight	617.3 lbs. / 280 kgs.	639 lbs. / 290 kgs.

Operation

The device is installed with an enclosed compressor with refrigerant R290 which has been indicated as an environmentally friendly agent. The product is operated under an air cooling system, maintaining the body temperature evenly.

1. Double hollow transparent glasses are used on the door and body, it features an artistic and elegant appearance, perfect perspective and easy access.
2. The device is commonly for commercial use, such as restaurants, convenience stores, clubs, ect.

BEFORE USE

- Plug refrigerator into the 110-120V exclusive socket.
- After the refrigerator is running, confirm that air suction/filtration is in order and that it is sufficiently cold. After checking to make sure the refrigerator is working properly, it may be used.

Operation

DIGITAL TEMPERATURE CONTROLLER

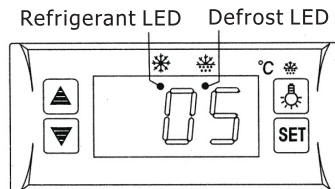

FEATURES OF FUNCTION

- Small, integrated digital controller, which is applicable to the compressor of 1 Hp.
- Main functions are: Temperature Display/Temperature Control/Manual-Automatic /Light Control/Value Storing/Self-Testing/Parameter Locking.

FRONT PANEL OPERATION

1. Set temperature: Press **SET** button; set temperature will be displayed. Press **▲** or **▼** button to modify and store the displayed value. Press **SET** button to exit the adjustment and display the cold-room temperature.
2. If no button is pressed within 10 seconds, the cold-room temperature will be displayed.
3. Lighting: Press **☹** button to activate light in refrigerator; press again to turn off. Manual start/stop defrost: Press **☹** button and hold for 6 seconds to either defrost or to stop defrost.
4. Refrigeration LED: During refrigeration, the LED is on. When the cold room temperature is constant, the LED is off. During delay start, the LED flashes.
5. Defrost LED: During defrosting, the LED is on. When it stops defrosting, the LED is off. During the delay of defrost, the LED flashed.

CAUTION

- Minimizing time the time and frequency that the door is open will maintain temperature.
- Never block the air outlet and suction to keep the air circulation and refrigeration capability constant.
- Do not overfill refrigerator with food, as it will influence the cooling effect. If needed, adjust the rack height for proper food storage.
- Cool down hot food to room temperature before placing inside the refrigerator.
- When power supply has been cut off, reduce opening times and maintain cool temperature in refrigerator.
- To avoid scalding, never touch the compressor.
- If the supply cord is damaged, it must be replaced by the manufacturer, its service agent, or similarly qualified persons in order to avoid hazard.
- This appliance is not intended for use by persons (including children) with reduced physical, sensory or mental capabilities, or lack of experience and knowledge, unless they have been given supervision or instruction concerning use of the appliance by a person responsible for their safety.
- Children should be supervised to ensure that they do not play with the appliance.

Maintenance

1. Cabinet Cleaning:
 - a. The product should be maintained and cleaned periodically with power supply disconnected. In cleaning, please use mild-rinsing water or non-corrosive products. Do not wash directly with water faucet.
 - b. Clean outside of unit using a soft cloth with neutral detergent, and dry with a separate soft cloth.
 - c. Clean inside racks by removing them from the unit and clean with water.
2. When shutting down unit for a long period of time, take out all food and unplug wall socket. Clean inside and outside thoroughly, and keep door open to sufficiently dry.
3. As glass breaks easily, keep far away from children.
4. Frequently observe the operation of the product. In case of any abnormal noise or smell, cut off the power supply immediately and call professionals. Do not restart the product before source of trouble is found.
5. We will not be responsible for any accidents acquired through failure to follow previous notices.

Troubleshooting

Trouble	Cause and Remedy
No Refrigeration	Is the plug securely in the socket?
	Is the fuse broken?
	Is there no power?
Poor Refrigeration	Is it under sunlight? Is there any heat source nearby?
	Is the surrounding ventilation poor?
	Is the door seal strip deformed or damaged?
	Is the food congested or is there too much food?
	Does food block the air suction or outlet?
	Regulate the temperature controller.
Noisy	The refrigerator is not level.
	The refrigerator is making contact with the wall or other objects.
	There is a loose part in the refrigerator.
Contact Omcan for help if simple trouble shooting does not solve the problems.	

NOTE

Following occurrences are not problems:

- The murmur of water is heard when the refrigerator is working. It is a normal occurrence as the coolant is circulating in the system.
- When the weather is damp, condensation might be found on the outside of the refrigerator. It is caused by high humidity. Simply use cloth to wipe it off.

Parts Breakdown

Model RS-CN-0271 44387

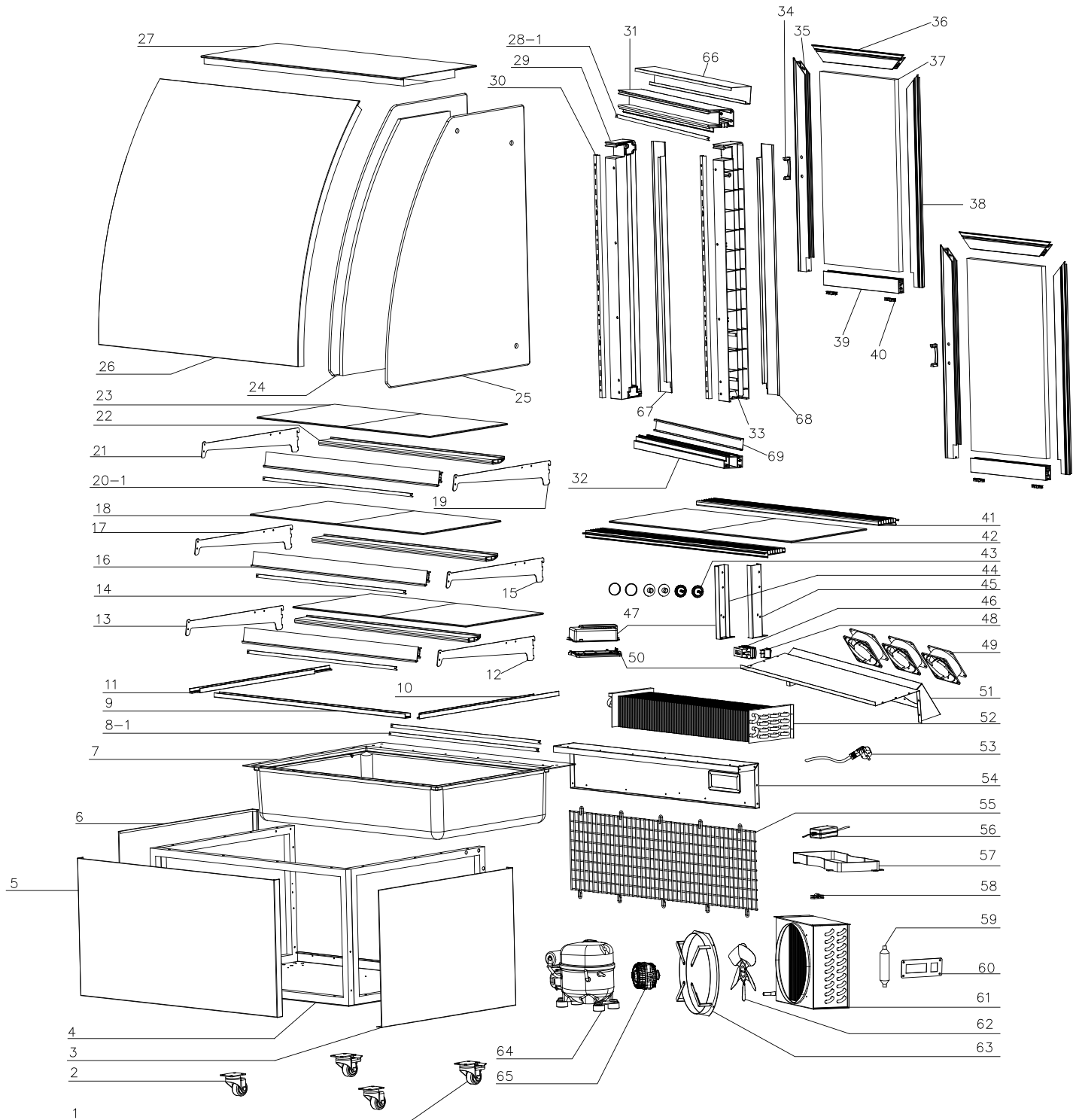



Parts Breakdown

Model RS-CN-0271 44387

Item No.	Description	Position	Item No.	Description	Position	Item No.	Description	Position
71042	Rear Swivel Caster with Brake for 44387	1	68180	Left Glass for 44387	24	71079	Thermostat Lid for 44387	47
79763	Swivel Front Castor without Brake for 44387	2	68186	Right Glass for 44387	25	68196	Switch for 44387	48
68164	Right Cover for 44387	3	AM504	Front Glass for 44387	26	71081	Evaporator Motor for 44387	49
68165	Base for 44387	4	AM023	Top Glass for 44387	27	71082	Thermostat Base for 44387	50
68166	Right Cover for 44387	5	AK200	Top LED for 44387	28-1	68197	Evaporator Cover for 44387	51
68167	Left Cover for 44387	6	AK201	6 LED Driver for 44387	28-2	71084	Evaporator for 44387	52
71046	Evaporator Insulation for 44387	7	68184	Left Pole for 44387	29	68198	Power Cord for 44387	53
68168	Bottom LED for 44387	8-1	68185	Shelf Holder for 44387	30	71086	Rear Frame for 44387	54
68176	Middle LED for 44387	8-1	68187	Top Frame for 44387	31	AM024	Back Grill for 44387	55
AG710	4 LED Driver #2 for 44387	8-2	68188	Bottom Frame for 44387	32	71089	Water Tray for 44387	57
68169	Front Glass Fixer for 44387	9	68189	Right Pole for 44387	33	AM025	Power Cord Fixer for 44387	58
68171	Left Glass Fixer for 44387	10	71110	Door Handle for 44387	34	71083	Dryer Filter for 44387	59
68170	Right Glass Fixer for 44387	11	68190	Left Door Frame for 44387	35	77434	Control Panel for 44387	60
68172	Right Bottom Shelf Holder for 44387	12	71068	Top Upper Door Frame for 44387	36	71135	Condenser for 44387	61
68211	Left Bottom Shelf Holder for 44387	13	AF526	Door Glass for 44387	37	71293	Fan Blade for 44387	62
68174	Bottom Glass Shelf for 44387	14	68192	Right Door Frame for 44387	38	71136	Fan Bracket for 44387	63
68175	Right Top Shelf Holder for 44387	15	71071	Bottom Door Frame for 44387	39	68199	Compressor for 44387	64
68173	Metal Price Tags for 44387	16	71114	Door Glide Wheel for 44387	40	71137	Condenser Motor for 44387	65
68177	Left Top Shelf Holder for 44387	17	68193	Air In/Outlet for 44387	41	AF506	Top Back Frame for 44387	66
68179	Top Glass Shelf for 44387	18	AD841	Bottom Glass for 44387	42	AF507	Left Back Frame for 44387	67
68276	Left Top Shelf Holder for 44387	19	71121	Screw Cover for 44387	43	AF508	Right Back Frame for 44387	68
68274	Right Top Shelf Holder for 44387	21	68194	Pole Fixer Left for 44387	44	AF509	Bottom Back Frame for 44387	69
68178	Metal Shelf Support for 44387	22	68195	Pole Fixer Right for 44387	45	AT601	Door Seal for 44387	
AF505	Small Glass Shelf for 44387	23	71123	Digital Control for 44387	46			

Parts Breakdown

Model RS-CN-0271-S 44382

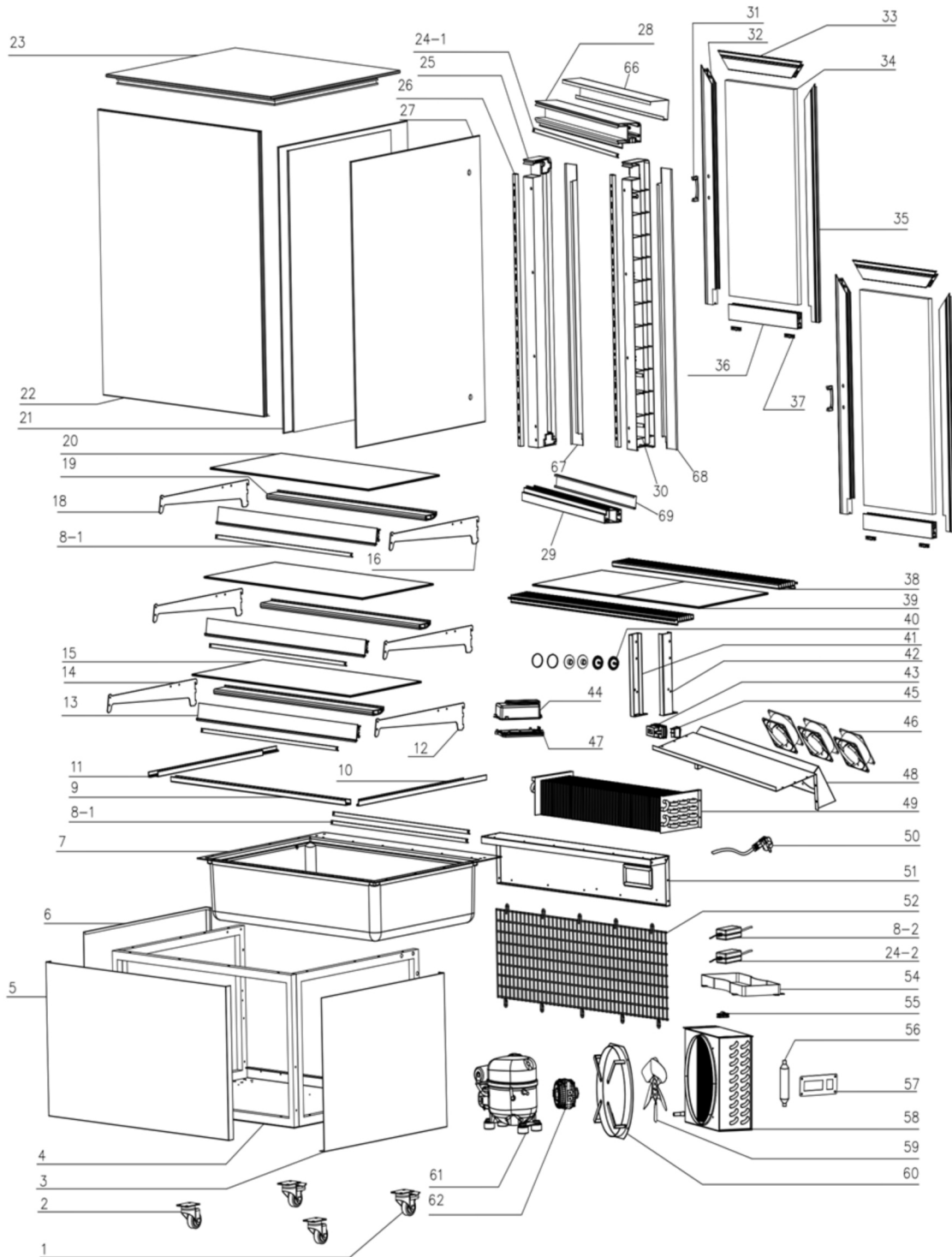

Parts Breakdown

Model RS-CN-0271-S 44382

Item No.	Description	Position	Item No.	Description	Position	Item No.	Description	Position
71042	Rear Swivel Castor with Brake for 44382	1	AK199	Top Glass for 44382	23	71123	Digital Control for 44382	43
79763	Swivel Front Castor without Brake for 44382	2	AK200	Top LED for 44382	24-1	71079	Thermostat Lid for 44382	44
68164	Right Cover for 44382	3	AK201	6 LED Driver for 44382	24-2	68196	Switch for 44382	45
68165	Base for 44382	4	68184	Left Pole for 44382	25	71081	Evaporator Motor for 44382	46
AU970	Front Cover for 44382	5	68185	Shelf Holder for 44382	26	71082	Thermostat Base for 44382	47
68167	Left Cover for 44382	6	68205	Right Glass for 44382	27	68197	Evaporator Cover for 44382	48
AS145	Evaporator Insulation for 44382	7	68187	Top Frame for 44382	28	71084	Evaporator for 44382	49
68176	Middle LED for 44382	8-1	AU971	Bottom Frame for 44382	29	68198	Power Cord for 44382	50
68168	Bottom LED for 44382	8-1	68189	Right Pole for 44382	30	71086	Rear Frame for 44382	51
AG710	4 LED Driver #2 for 44382	8-2	71110	Door Handle for 44382	31	AM024	Back Grill for 44382	52
68169	Front Glass Fixer for 44382	9	AU972	Left Doorframe for 44382	32	71089	Water Tray for 44382	54
68171	Left Glass Fixer for 44382	10	AU973	Top Upper Door Frame for 44382	33	AS151	Power Cord Fixer for 44382	55
68170	Right Glass Fixer for 44382	11	AF526	Door Glass for 44382	34	71083	Dryer Filter for 44382	56
68172	Right Bottom Shelf Holder for 44382	12	AU974	Right Doorframe for 44382	35	77434	Control Panel for 44382	57
68173	Metal Price Tags for 44382	13	AU975	Bottom Door Frame for 44382	36	71135	Condenser for 44382	58
68211	Left Bottom Shelf Holder for 44382	14	AU976	Door Glidewheel for 44382	37	AU979	Fan Blade for 44382	59
68174	Bottom Glass Shelf for 44382	15	AU977	Door Glidewheel for 44382	37	71136	Fan Bracket for 44382	60
68175	Right Top Shelf Holder for 44382	16	AU978	Door Glidewheel for 44382	37	68199	Compressor for 44382	61
68177	Left Top Shelf Holder for 44382	18	68193	Air In/Outlet for 44382	38	AP880	Motor 120V 60Hz 1.01Amp 1550RPM for 44382	62
68178	Metal Shelf Support for 44382	19	AD841	Bottom Glass for 44382	39	AF506	Top Back Frame for 44382	66
68179	Top Glass Shelf for 44382	20	71121	Screw Cover for 44382	40	AF502	Left Back Frame for 44382	67
68200	Left Glass for 44382	21	68194	Pole Fixer Left for 44382	41	AF503	Right Back Frame for 44382	68
AM027	Front Glass for 44382	22	68195	Pole Fixer Right for 44382	42	AF509	Bottom Back Frame for 44382	69

Parts Breakdown

Model RS-CN-0371 44502

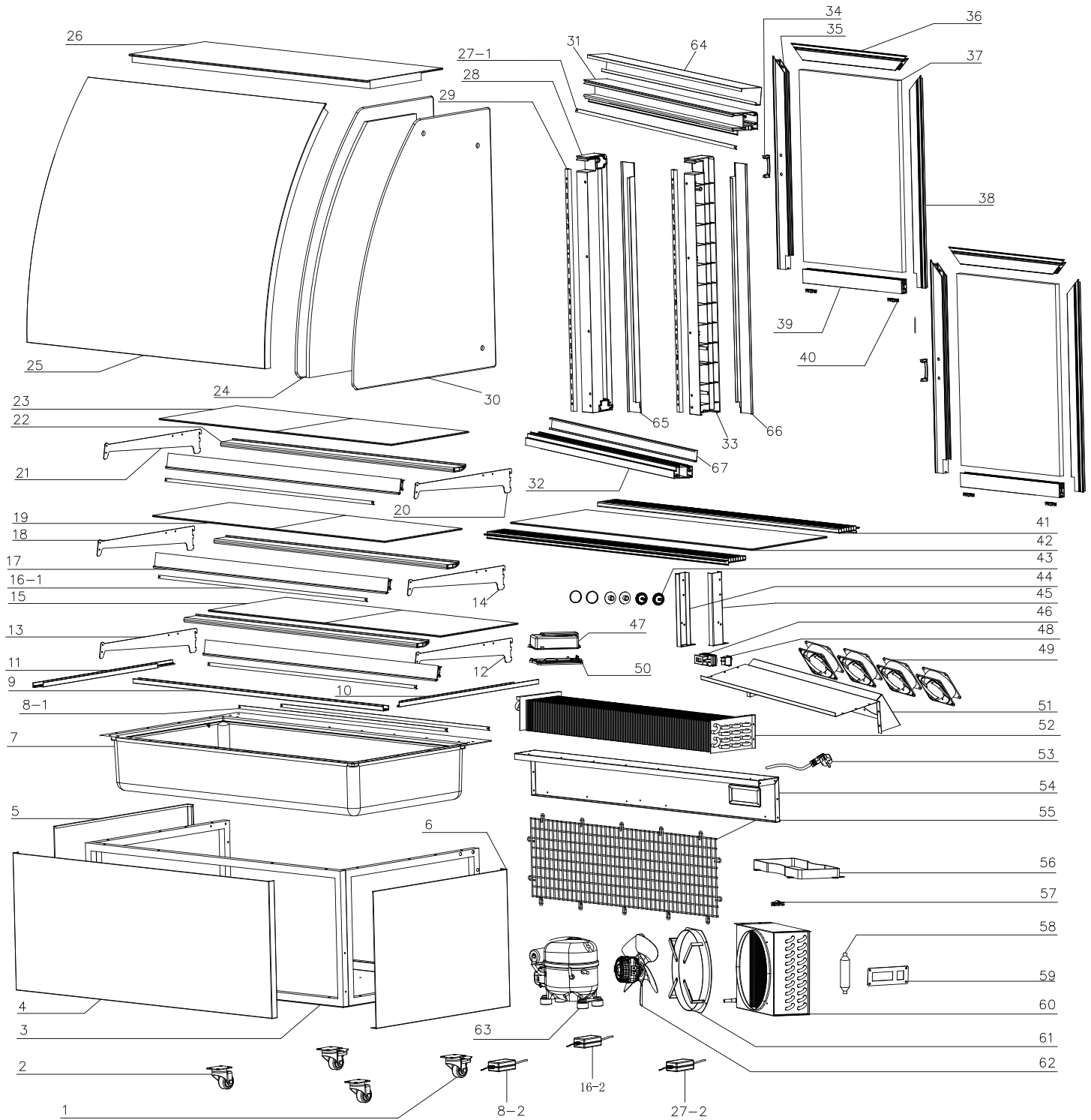

Parts Breakdown

Model RS-CN-0371 44502

Item No.	Description	Position	Item No.	Description	Position	Item No.	Description	Position
71042	Rear Swivel Castor with Brake for 44502	1	AM030	Small Glass Shelf for 44502	23	71123	Digital Control for 44502	46
79763	Swivel Front Castor without Brake for 44502	2	68180	Left Glass for 44502	24	71079	Thermostat Lid for 44502	47
68206	Base for 44502	3	AM031	Front Glass for 44502	25	68196	Switch for 44502	48
68207	Front Cover for 44502	4	68216	Top Glass for 44502	26	71081	Evaporator Motor for 44502	49
68167	Left Cover for 44502	5	AF496	Top LED for 44502	27-1	71082	Thermostat Base for 44502	50
68164	Right Cover for 44502	6	AK201	6 LED Driver for 44502	27-2	68227	Evaporator Cover for 44502	51
71094	Evaporator Insulation for 44502	7	68184	Left Pole for 44502	28	71127	Evaporator for 44502	52
68208	Bottom LED for 44502	8-1	68185	Shelf Holder for 44502	29	68198	Power Cord for 44502	53
AK203	4 LED Driver for 44502	8-2, 16-2	68186	Right Glass for 44502	30	71129	Rear Frame for 44502	54
68209	Front Glass Fixer for 44502	9	68217	Top Frame for 44502	31	AM032	Back Grill for 44502	55
AM029	Right Glass Fixer for 44502	10	68218	Bottom Frame for 44502	32	71089	Water Tray for 44502	56
68171	Left Glass Fixer for 44502	11	68189	Right Pole for 44502	33	AM025	Power Cord Fixer for 44502	57
68172	Right Bottom Shelf Holder for 44502	12	71110	Door Handle for 44502	34	71083	Dryer Filter for 44502	58
68211	Left Bottom Shelf Holder for 44502	13	68190	Left Door Frame for 44502	35	77434	Control Panel for 44502	59
68175	Right Top Shelf Holder for 44502	14	71111	Upper Door Frame for 44502	36	71135	Condenser for 44502	60
68212	Bottom Glass Shelf for 44502	15	68192	Right Door Frame for 44502	38	71136	Fan Bracket for 44502	61
71149	LED Lighter for 44502	16-1	71167	Bottom Door Frame for 44502	39	71137	Condenser Motor for 44502	62
68210	Metal Price Tags for 44502	17	71114	Door Glide Wheel for 44502	40	68199	Compressor for 44502	63
68177	Left Top Shelf Holder for 44502	18	AK204	Air In/Outlet for 44502	41	AF501	Top Back Frame for 44502	64
68214	Top Glass Shelf for 44502	19	AD842	Bottom Glass for 44502	42	AF507	Left Back Frame for 44502	65
68276	Left Top Shelf Holder for 44502	20	71121	Screw Cover for 44502	43	AF508	Right Back Frame for 44502	66
68274	Right Top Shelf Holder for 44502	21	68194	Pole Fixer Left for 44502	44	AF504	Bottom Back Frame for 44502	67
68213	Metal Shelf Support for 44502	22	68195	Pole Fixer Right for 44502	45	AT601	Door Seal for 44502	

Parts Breakdown

Model RS-CN-0371-S 44383

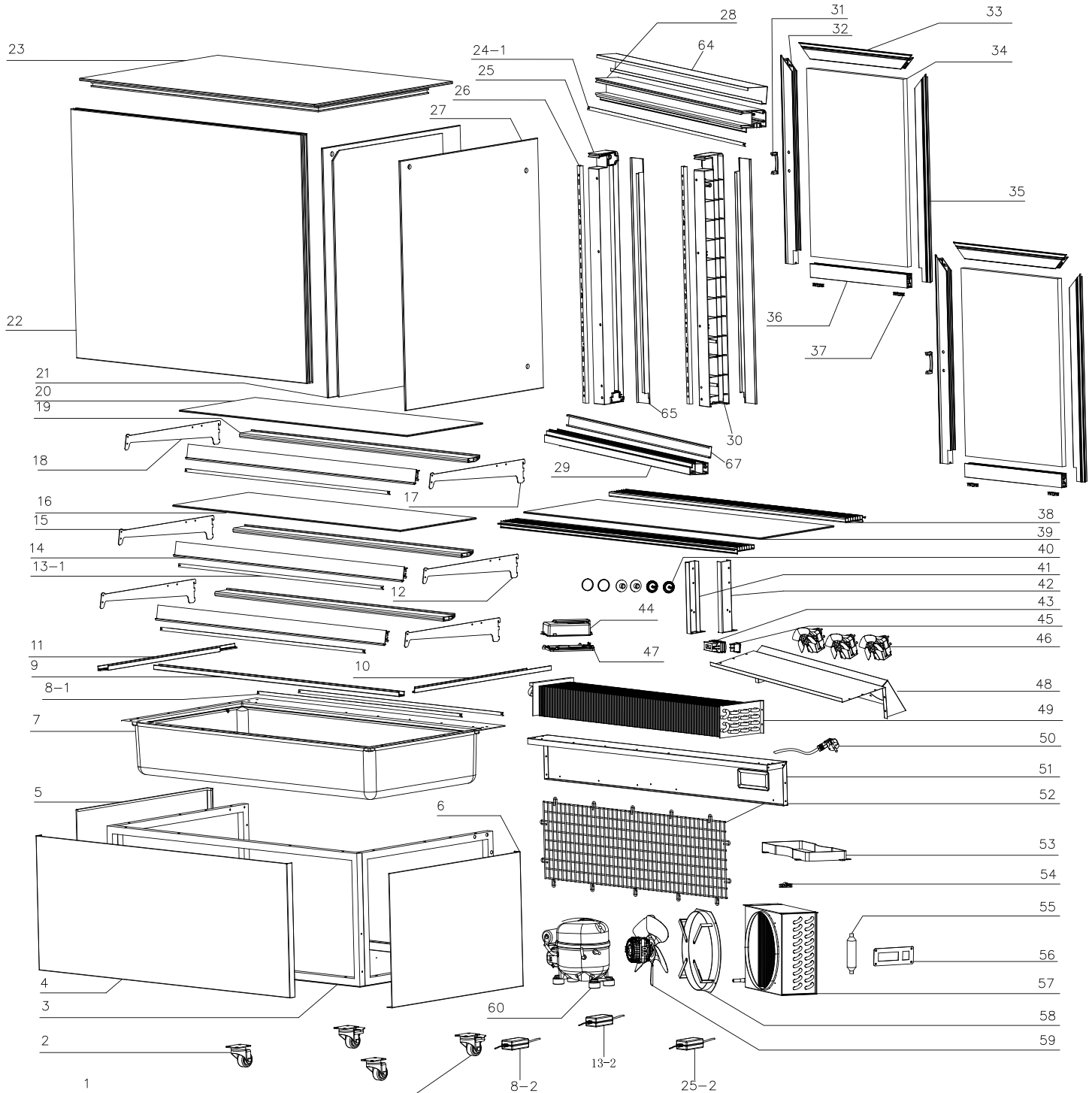

Parts Breakdown

Model RS-CN-0371-S 44383

Item No.	Description	Position	Item No.	Description	Position	Item No.	Description	Position
71042	Rear Swivel Castor with Brake for 44383	1	AL781	Front Glass 1219x857mm for 44383	22	71079	Thermostat Lid for 44383	44
79763	Swivel Front Castor without Brake for 44383	2	AF499	Top Glass for 44383	23	68196	Switch for 44383	45
68206	Base for 44383	3	AF496	Top LED for 44383	24-1	71081	Evaporator Motor for 44383	46
68207	Front Cover for 44383	4	68184	Left Pole for 44383	25	71082	Thermostat Base for 44383	47
68167	Left Cover for 44383	5	60674	LED Transformer for 44383	25-2	68227	Evaporator Cover for 44383	48
68164	Right Cover for 44383	6	68185	Shelf Holder for 44383	26	71127	Evaporator for 44383	49
71094	Evaporator Insulation for 44383	7	68205	Right Glass for 44383	27	AE392	Power Cord for 44383	50
68208	Bottom LED for 44383	8-1	68217	Top Frame for 44383	28	71129	Rear Frame for 44383	51
67652	LED Transformer for 44383	8-2, 13-2	68218	Bottom Frame for 44383	29	AM032	Back Grill for 44383	52
68209	Front Glass Fixer for 44383	9	68189	Right Pole for 44383	30	71089	Water Tray for 44383	53
68171	Left Glass Fixer for 44383	10	71110	Door Handle for 44383	31	AM025	Power Cord Fixer for 44383	54
68170	Right Glass Fixer for 44383	11	68190	Left Door Frame for 44383	32	71083	Dryer Filter for 44383	55
68172	Right Bottom Shelf Holder for 44383	12	71111	Upper Door Frame for 44383	33	77434	Control Panel for 44383	56
71149	LED Lighter for 44383	13-1	68192	Right Door Frame for 44383	35	71135	Condenser for 44383	57
68210	Metal Price Tags for 44383	14	71167	Bottom Door Frame for 44383	36	71136	Fan Bracket for 44383	58
68211	Left Bottom Shelf Holder for 44383	15	71114	Door Glide Wheel for 44383	37	71137	Condenser Motor for 44383	59
68212	Bottom Glass Shelf for 44383	16	AM033	Air In/Outlet for 44383	38	68199	Compressor for 44383	60
68175	Right Top Shelf Holder for 44383	17	AD842	Bottom Glass for 44383	39	AF501	Top Back Frame for 44383	61
68177	Left Top Shelf Holder for 44383	18	71121	Screw Cover for 44383	40	AF502	Left Back Frame for 44383	62
68213	Metal Shelf Support for 44383	19	68194	Pole Fixer Left for 44383	41	AF503	Right Back Frame for 44383	63
68214	Top Glass Shelf for 44383	20	68195	Pole Fixer Right for 44383	42	AF504	Bottom Back Frame for 44383	64
68200	Left Glass for 44383	21	71123	Digital Control for 44383	43	AT601	Door Seal for 44383	

Parts Breakdown

Model RS-CN-0471 44503

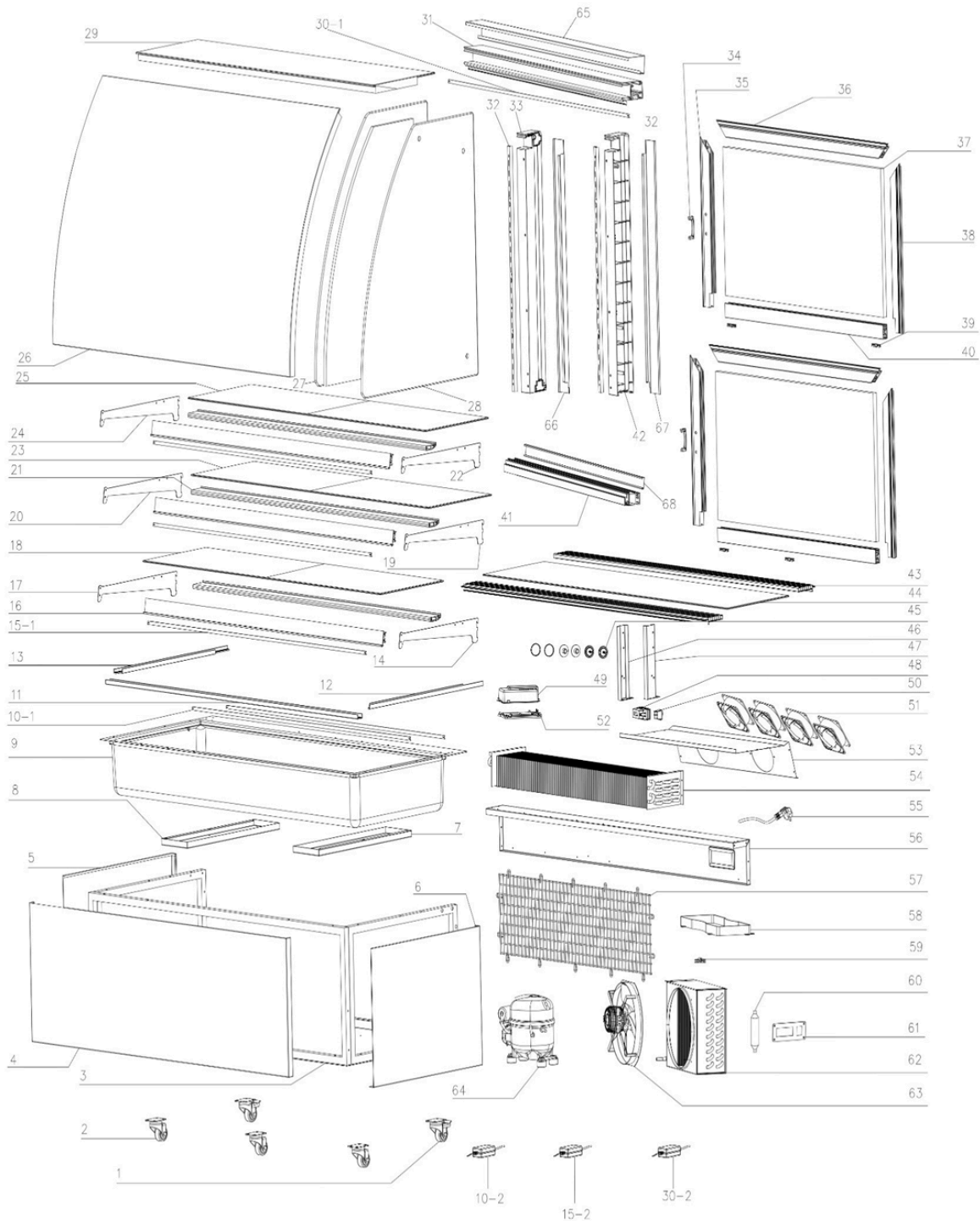

Parts Breakdown

Model RS-CN-0471 44503

Item No.	Description	Position	Item No.	Description	Position	Item No.	Description	Position
71042	Rear Swivel Caster with Brake for 44503	1	68239	Glass Shelf for Top or Middle for 44503	23	68194	Pole Fixer Left for 44503	46
79763	Swivel Front Castor without Brake for 44503	2	68274	Right Top Shelf Holder for 44503	24	68195	Pole Fixer Right for 44503	47
68228	Base for 44503	3	AK206	Small Glass Shelf for 44503	25	71123	Digital Control for 44503	48
68229	Front Cover for 44503	4	AR620	Front Glass for 44503	26	71079	Thermostat Lid for 44503	49
68167	Left Cover for 44503	5	68180	Left Glass for 44503	27	68196	Switch for 44503	50
68164	Right Cover for 44503	6	68186	Right Glass for 44503	28	71081	Evaporator Motor for 44503	51
68231	Right Blister Barrel Fixing Plate for 44503	7	AK208	Top Glass for 44503	29	71082	Thermostat Base for 44503	52
68230	Left Blister Barrel Fixing Plate for 44503	8	68242	Top LED for 44503	30-1	68227	Evaporator Cover for 44503	53
AR619	Evaporator Frame for 44503	9	AK209	5 LED Driver for 44503	30-2	71127	Evaporator for 44503	54
68208	Bottom LED for 44503	10-1	68243	Top Frame for 44503	31	AK205	Power Cord for 44503	55
AK203	4 LED Driver for 44503	10-2	68185	Shelf Holder for 44503	32	68249	Rear Frame for 44503	56
68233	Front Glass Fixer for 44503	11	68184	Left Pole for 44503	33	AM036	Back Grill for 44503	57
AM034	Right Glass Fixer for 44503	12	71110	Door Handle for 44503	34	71089	Water Tray for 44503	58
AM035	Left Glass Fixer for 44503	13	68190	Left Door Frame for 44503	35	AM025	Power Cord Fixer for 44503	59
68172	Right Bottom Shelf Holder for 44503	14	AF514	Top Door Frame for 44503	36	71083	Dryer Filter for 44503	60
68234	Middle LED for 44503	15-1	AK210	Door Glass for 44503	37	77434	Control Panel for 44503	61
AG710	4 LED Driver #2 for 44503	15-2	68192	Right Door Frame for 44503	38	AR621	Condenser for 44503	62
68236	Metal Price Tags for 44503	16	71114	Door Glide Wheel for 44503	39	68287	Condenser Fan Motor for 44503	63
68211	Left Bottom Shelf Holder for 44503	17	68245	Bottom Door Frame for 44503	40	68199	Compressor for 44503	64
68237	Bottom Glass Shelf for 44503	18	68246	Bottom Frame for 44503	41	AF512	Top Back Frame for 44503	65
68175	Right Top Shelf Holder for 44503	19	68189	Right Pole for 44503	42	AF507	Left Back Frame for 44503	66
68177	Left Top Shelf Holder for 44503	20	AK211	Air In/Outlet for 44503	43	AF508	Right Back Frame for 44503	67
68238	Metal Shelf Support for 44503	21	AK212	Bottom Glass Frame for 44503	44	AF513	Bottom Back Frame for 44503	68
68276	Left Top Shelf Holder for 44503	22	71121	Screw Cover for 44503	45	AT601	Door Seal for 44503	

Parts Breakdown

Model RS-CN-0471-S 44384

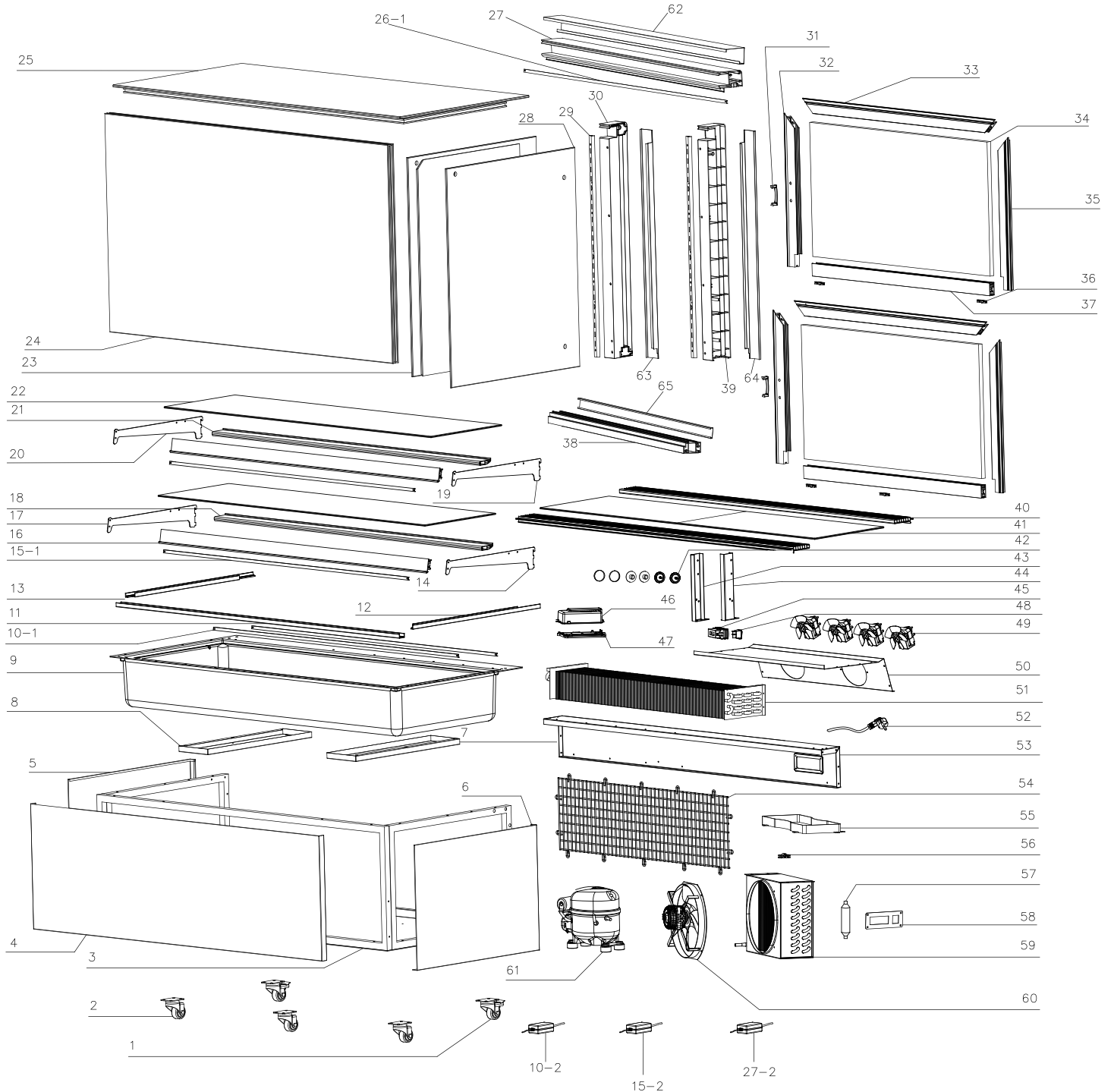



Parts Breakdown

Model RS-CN-0471-S 44384

Item No.	Description	Position	Item No.	Description	Position	Item No.	Description	Position
71042	Rear Swivel Castor with Brake for 44384	1	68239	Glass Shelf for Top or Middle for 44384	22	68195	Pole Fixer Right for 44384	44
79763	Swivel Front Castor without Brake for 44384	2	68200	Left Glass for 44384	23	71123	Digital Control for 44384	45
68228	Base for 44384	3	AM037	Front Glass for 44384	24	71079	Thermostat Lid for 44384	46
68229	Front Cover for 44384	4	AK214	Top Glass for 44384	25	71082	Thermostat Base for 44384	47
68167	Left Cover for 44384	5	68242	Top LED for 44384	26-1	68196	Switch for 44384	48
68164	Right Cover for 44384	6	68243	Top Frame for 44384	27	71081	Evaporator Motor for 44384	49
68231	Right Blister Barrel Fixing Plate for 44384	7	AK209	5 LED Driver for 44384	27-2	68227	Evaporator Cover for 44384	50
68230	Left Blister Barrel Fixing Plate for 44384	8	68205	Right Glass for 44384	28	71127	Evaporator for 44384	51
68232	Evaporator Insulation for 44384	9	68185	Shelf Holder for 44384	29	AK205	Power Cord for 44384	52
68208	Bottom LED for 44384	10-1	68184	Left Pole for 44384	30	68249	Rear Frame for 44384	53
AK203	4 LED Driver for 44384	10-2	71110	Door Handle for 44384	31	AM036	Back Grill for 44384	54
68233	Front Glass Fixer for 44384	11	68190	Left Door Frame for 44384	32	71089	Water Tray for 44384	55
68171	Left Glass Fixer for 44384	12	AF514	Top Door Frame for 44384	33	AM025	Power Cord Fixer for 44384	56
68170	Right Glass Fixer for 44384	13	AK210	Door Glass for 44384	34	71083	Dryer Filter for 44384	57
68172	Right Bottom Shelf Holder for 44384	14	68192	Right Door Frame for 44384	35	AM038	Control Panel for 44384	58
68234	Middle LED for 44384	15-1	71114	Door Glide Wheel for 44384	36	68286	Condenser for 44384	59
AG710	4 LED Driver #2 for 44384	15-2	68245	Bottom Door Frame for 44384	37	68287	Condenser Fan Motor for 44384	60
68236	Metal Price Tags for 44384	16	68246	Bottom Frame for 44384	38	68199	Compressor for 44384	61
68211	Left Bottom Shelf Holder for 44384	17	68189	Right Pole for 44384	39	AF512	Top Back Frame for 44384	63
68237	Bottom Glass Shelf for 44384	18	AK211	Air In/Outlet for 44384	40	AF502	Left Back Frame for 44384	64
68175	Right Top Shelf Holder for 44384	19	AK212	Bottom Glass Frame for 44384	41	AF503	Right Back Frame for 44384	65
68177	Left Top Shelf Holder for 44384	20	71121	Screw Cover for 44384	42	AF513	Bottom Back Frame for 44384	66
68238	Metal Shelf Support for 44384	21	68194	Pole Fixer Left for 44384	43	AT601	Door Seal for 44384	

Parts Breakdown

Model RS-CN-0571 44504

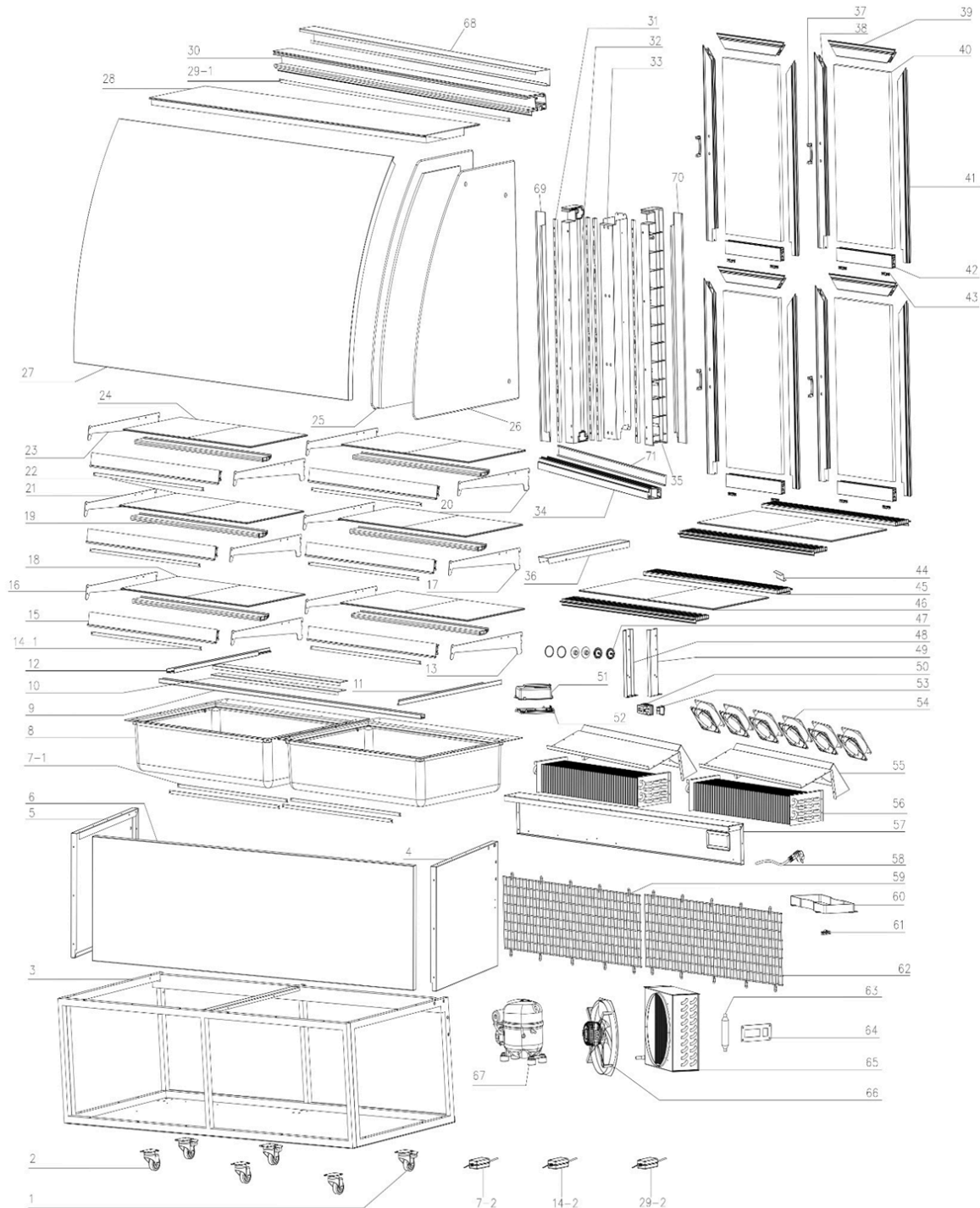

Parts Breakdown

Model RS-CN-0571 44504

Item No.	Description	Position	Item No.	Description	Position	Item No.	Description	Position
71042	Rear Swivel Caster with Brake for 44504	1	68180	Left Glass for 44504	25	AK226	Digital Controller for 44504	50
79763	Swivel Front Castor without Brake for 44504	2	68186	Right Glass for 44504	26	71079	Thermostat Lid for 44504	51
68203	Base for 44504	3	AM040	Front Glass for 44504	27	71082	Thermostat Base for 44504	52
68164	Right Cover for 44504	4	AM041	Top Glass for 44504	28	68196	Switch for 44504	53
68167	Left Cover for 44504	5	AF525	Top LED for 44504	29-1	AK227	Evaporator Motor for 44504	54
AK215	Front Cover for 44504	6	AK201	6 LED Driver for 44504	29-2	68197	Evaporator Cover for 44504	55
68168	Bottom LED for 44504	7-1	AK221	Top Frame for 44504	30	71084	Evaporator for 44504	56
AG710	4 LED Driver #2 for 44504	7-2, 14-2	68185	Shelf Holder for 44504	31	AK229	Rear Frame for 44504	57
71046	Evaporator Insulation for 44504	8	68184	Left Pole for 44504	32	AK205	Power Cord for 44504	58
AK216	Front Glass Fixer for 44504	9	AK222	Middle Column for 44504	33	AK230	Left Back Grill for 44504	59
AM039	After Air Vent Fixed Parts for 44504	10, 44	AK223	Bottom Frame for 44504	34	71089	Water Tray for 44504	60
68171	Left Glass Fixer for 44504	11	68189	Right Pole for 44504	35	AM025	Power Cord Fixer for 44504	61
68170	Right Glass Fixer for 44504	12	68283	Middle Cover Plate for 44504	36	AM044	Right Back Grill for 44504	62
68172	Right Bottom Shelf Holder for 44504	13	71110	Door Handle for 44504	37	AM045	Dry Filter for 44504	63
68176	Middle LED for 44504	14-1	68190	Left Door Frame for 44504	38	77434	Control Panel for 44504	64
AK217	Metal Price Tags for 44504	15	71068	Top Upper Door Frame for 44504	39	AR621	Condenser for 44504	65
68211	Left Bottom Shelf Holder for 44504	16	AM042	Door Glass for 44504	40	AP880	Motor 120V 60Hz 1.01AMP 1550RPM for 44504	66
68175	Right Top Shelf Holder for 44504	17	68192	Right Door Frame for 44504	41	68199	Compressor for 44504	67
68273	Bottom Glass Shelf for 44504	18	71071	Bottom Door Frame for 44504	42	AF521	Top Back Frame for 44504	68
AK218	Metal Shelf Support for 44504	19	71114	Door Glade Wheel for 44504	43	AF507	Left Back Frame for 44504	69
68276	Left Top Shelf Holder for 44504	20	AF520	Air In/Outlet for 44504	45	AF508	Right Back Frame for 44504	70
68177	Left Top Shelf Holder for 44504	21	AK225	Bottom Frosted Glass for 44504	46	AF522	Bottom Back Frame for 44504	71
68275	Middle/Top Glass Shelf for 44504	22	71121	Screw Cover for 44504	47	AT601	Door Seal for 44504	
68274	Right Top Shelf Holder for 44504	23	AM043	Pole Fixer (Left) for 44504	48			
AF519	Small Glass Shelf for 44504	24	68195	Pole Fixer Right for 44504	49			

Parts Breakdown

Model RS-CN-0571-S 44505

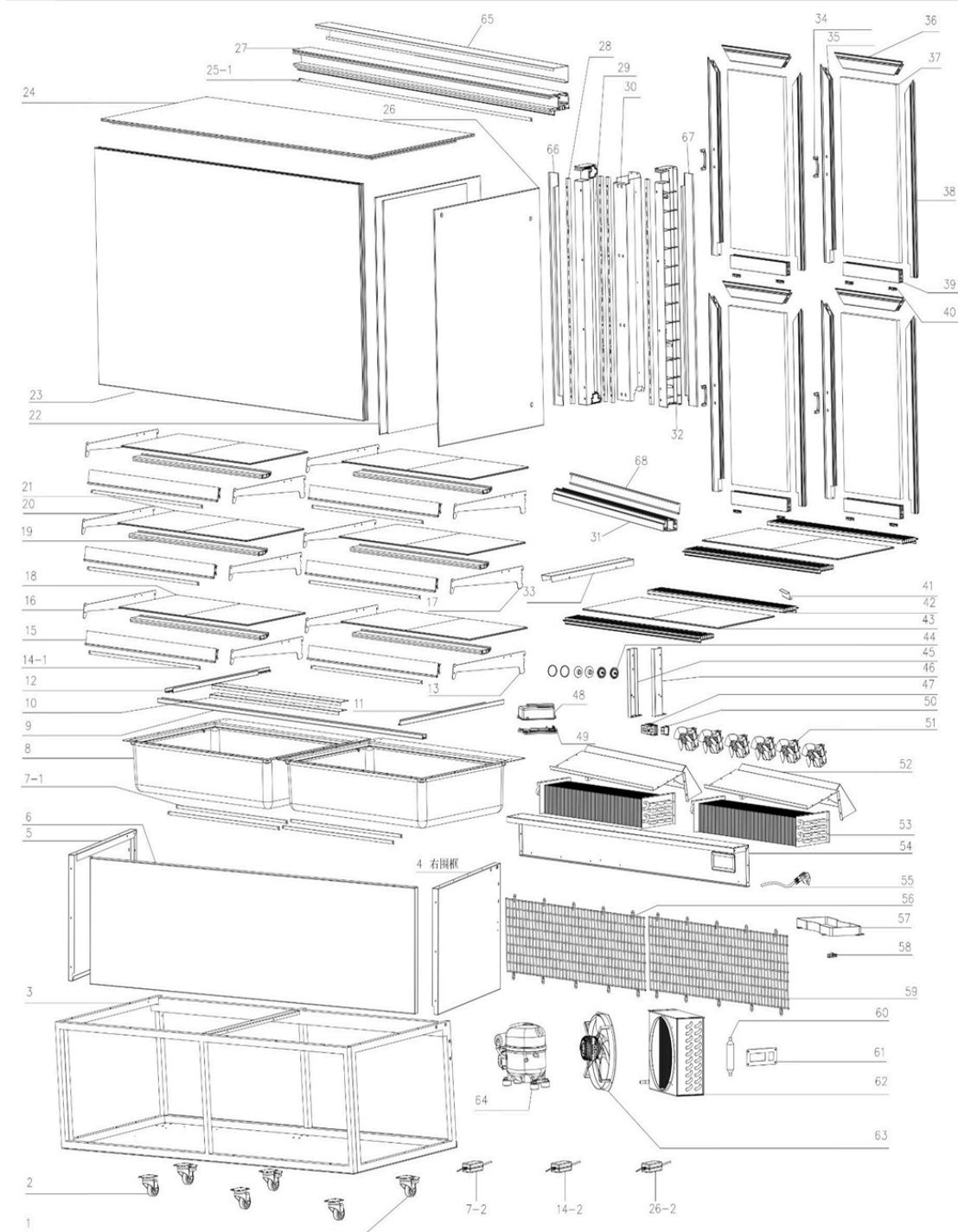

Parts Breakdown

Model RS-CN-0571-S 44505

Item No.	Description	Position	Item No.	Description	Position	Item No.	Description	Position
71042	Rear Swivel Caster with Brake for 44505	1	AF524	Top Glass for 44505	24	71123	Digital Control for 44505	47
79763	Swivel Front Castor without Brake for 44505	2	AF525	Top LED for 44505	25-1	71079	Thermostat Lid for 44505	48
68203	Base for 44505	3	AK232	Right Glass for 44505	26	71082	Thermostat Base for 44505	49
AM046	Right Cover for 44505	4	AK201	6 LED Driver for 44505	26-2	68196	Switch for 44505	50
AM047	Left Cover for 44505	5	AK221	Top Frame for 44505	27	71081	Evaporator Motor for 44505	51
AJ491	Pull Out the Door for 44505	6	AM049	Shelf Holder for 44505	28	68197	Evaporator Cover for 44505	52
68168	Bottom LED for 44505	7-1	AM050	Left Pole for 44505	29	71084	Evaporator for 44505	53
AG710	4 LED Driver #2 for 44505	7-2, 14-2	AK222	Middle Column for 44505	30	AK229	Rear Frame for 44505	54
71046	Evaporator Insulation for 44505	8	AK223	Bottom Frame for 44505	31	AK205	Power Cord for 44505	55
AK216	Front Glass Fixer for 44505	9	AM051	Right Pole for 44505	32	AK230	Left Back Grill for 44505	56
AM048	After Air Vent Fixed Parts for 44505	10	AK233	Middle Cover Plate for 44505	33	71089	Water Tray for 44505	57
68171	Left Glass Fixer for 44505	11	71110	Door Handle for 44505	34	AM025	Power Cord Fixer for 44505	58
68170	Right Glass Fixer for 44505	12	68190	Left Door Frame for 44505	35	AM044	Right Back Grill for 44505	59
68172	Right Bottom Shelf Holder for 44505	13	71068	Top Upper Door Frame for 44505	36	AM045	Dry Filter for 44505	60
68176	Middle LED for 44505	14-1	AF526	Door Glass for 44505	37	77434	Control Panel for 44505	61
AK217	Metal Price Tags for 44505	15	68192	Right Door Frame for 44505	38	AR621	Condenser for 44505	62
68211	Left Bottom Shelf Holder for 44505	16	71071	Bottom Door Frame for 44505	39	68287	Condenser Fan Motor for 44505	63
68175	Right Top Shelf Holder for 44505	17	71114	Door Glide Wheel for 44505	40	68199	Compressor for 44505	64
68273	Bottom Glass Shelf for 44505	18	AM039	After Air Vent Fixed Parts for 44505	41	AF521	Top Back Frame for 44505	65
AJ522	V-Shaped Heating Pipe for 44505	19	AF520	Air In/Outlet for 44505	42	AF502	Left Back Frame for 44505	66
68177	Left Top Shelf Holder for 44505	20	AK225	Bottom Frosted Glass for 44505	43	AF503	Right Back Frame for 44505	67
68275	Middle/Top Glass Shelf for 44505	21	71121	Screw Cover for 44505	44	AF522	Bottom Back Frame for 44505	68
68200	Left Glass for 44505	22	AM043	Pole Fixer (Left) for 44505	45	AT601	Door Seal for 44505	
AK231	Front Glass for 44505	23	68195	Pole Fixer Right for 44505	46			

Electrical Schematics

Model RS-CN-0271 44387

Model RS-CN-0271-S 44382

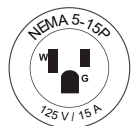
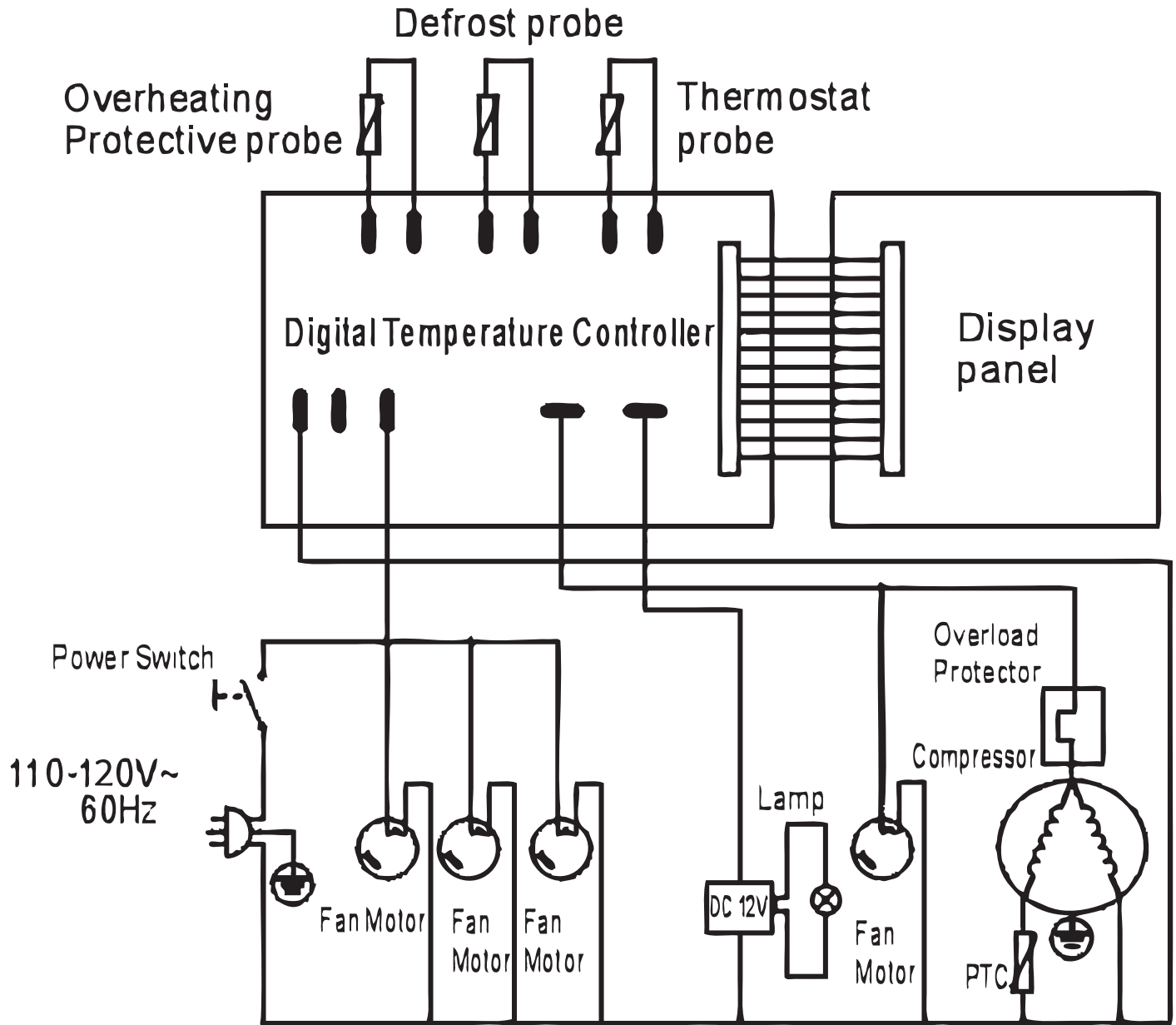

Electrical Schematics

Model RS-CN-0371 44502

Model RS-CN-0371-S 44383

Model RS-CN-0471 44503

Model RS-CN-0471-S 44384

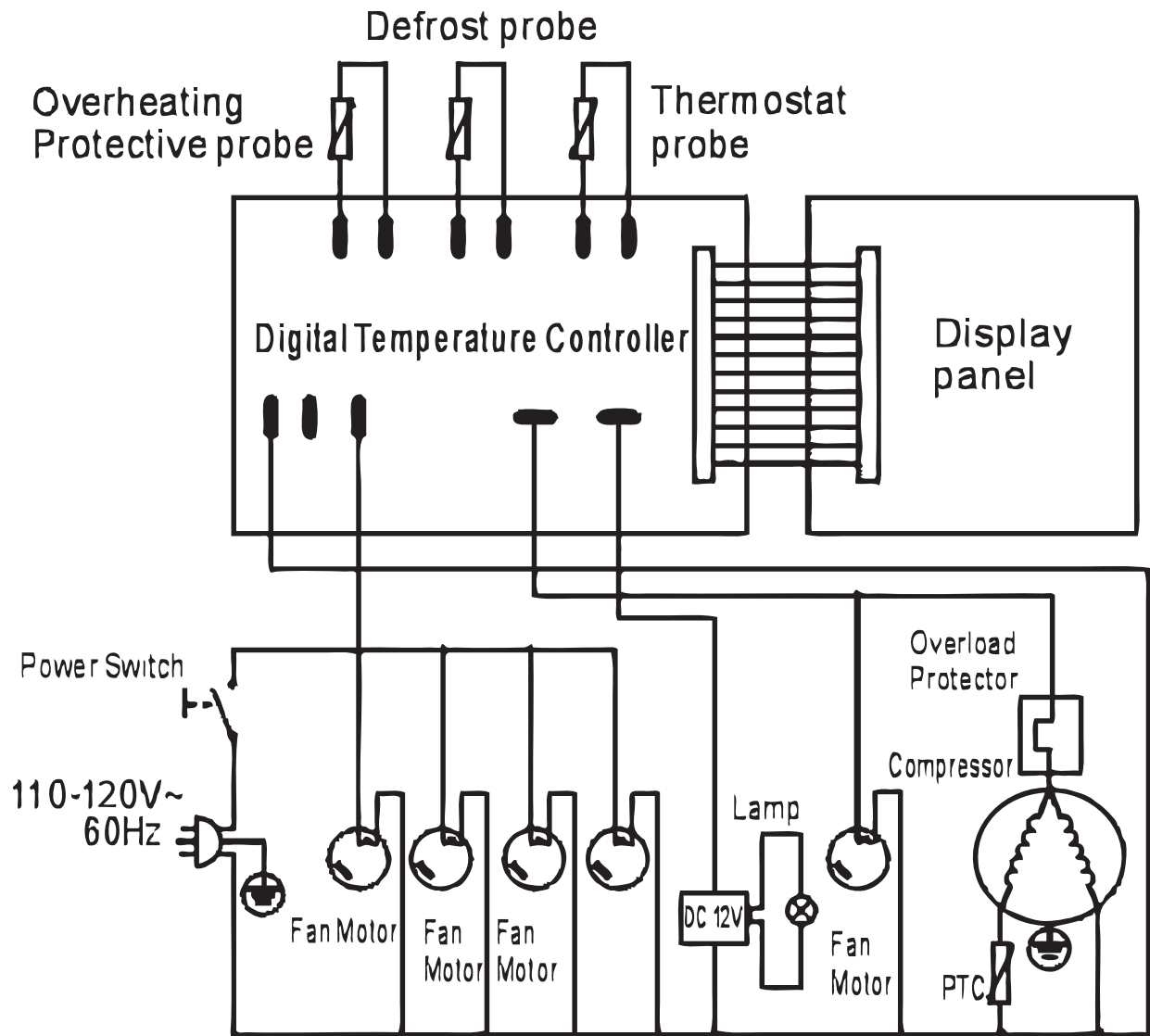

Electrical Schematics

Model RS-CN-0571 44504

Model RS-CN-0571-S 44505

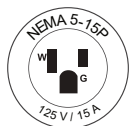
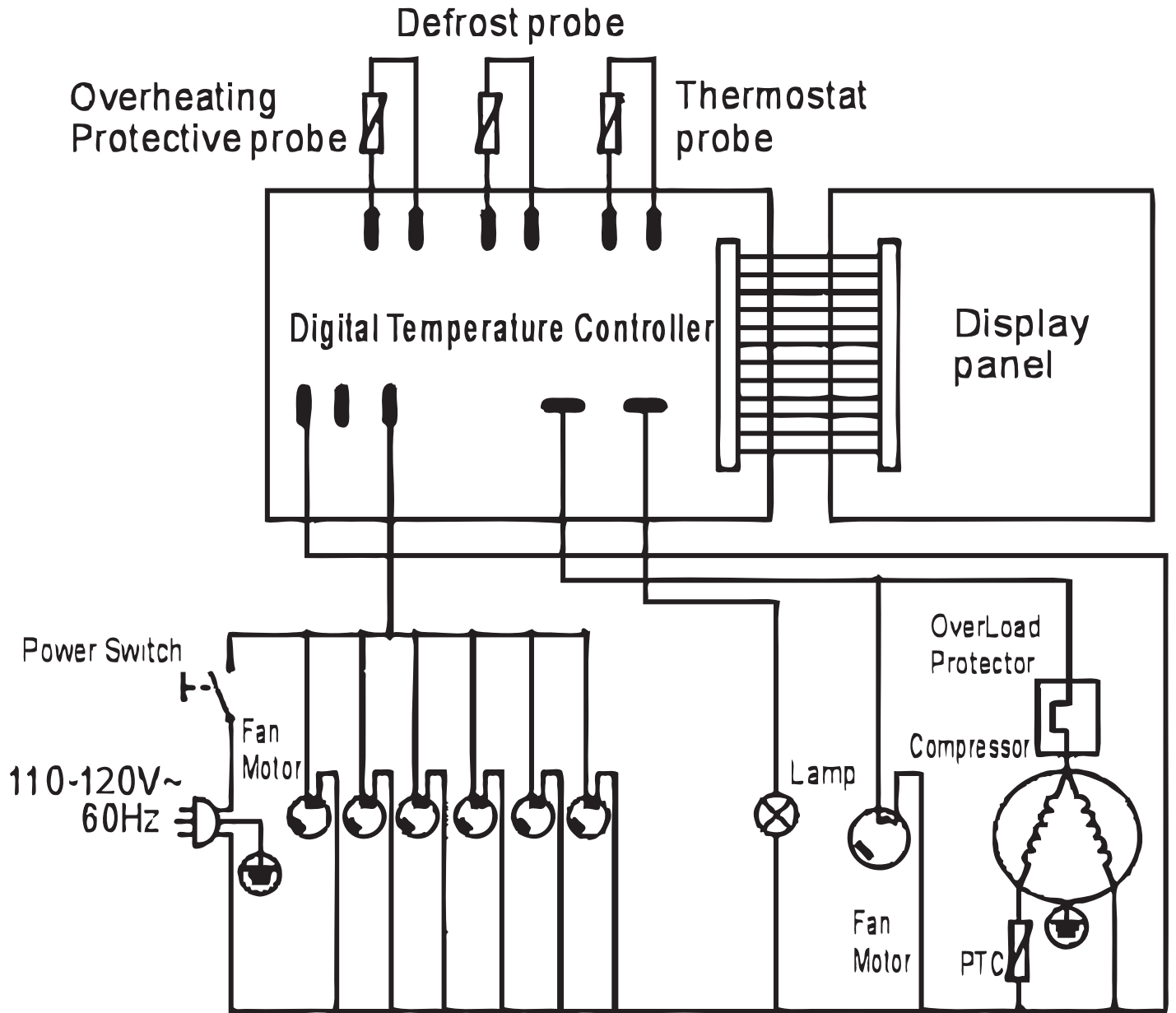



Warranty Registration

Thank you for purchasing an Omcan product. To register your warranty for this product, complete the information below, tear off the card at the perforation and then send to the address specified below. You can also register online by visiting:

Merci d'avoir acheté un produit Omcan. Pour enregistrer votre garantie pour ce produit, complétez les informations ci-dessous, détachez la carte au niveau de la perforation, puis l'envoyer à l'adresse spécifiée ci-dessous. Vous pouvez également vous inscrire en ligne en visitant:

Gracias por comprar un producto Omcan usted. Para registrar su garantía para este producto, complete la información a continuación, cortar la tarjeta en la perforación y luego enviarlo a la dirección indicada a continuación. También puede registrarse en línea en:

<https://omcan.com/warranty-registration/>

For mailing in Canada

Pour postale au Canada

Por correo en Canadá

For mailing in the US

Pour diffusion aux États-Unis

Por correo en los EE.UU.

OMCAN

PRODUCT WARRANTY REGISTRATION

3115 Pepper Mill Court,
Mississauga, Ontario
Canada, L5L 4X5

OMCAN

PRODUCT WARRANTY REGISTRATION

4450 Witmer Industrial Estates, Unit 4,
Niagara Falls, New York
USA, 14305

or email to: service@omcan.com



Purchaser's Information

Name: _____

Address: _____

City: _____ Province or State: _____ Postal or Zip: _____

Country: _____

Dealer from which Purchased: _____

Dealer City: _____ Dealer Province or State: _____

Invoice: _____

Model Name: _____ Model Number: _____

Machine Description: _____

Date of Purchase (MM/DD/YYYY): _____

Would you like to extend the warranty? Yes No

Company Name: _____

Telephone: _____

Email Address: _____

Type of Company:

Restaurant Bakery Deli

Butcher Supermarket Caterer

Institution (*specify*): _____

Other (*specify*): _____

Serial Number: _____

Date of Installation (MM/DD/YYYY): _____

Thank you for choosing Omcan | Merci d'avoir choisi Omcan | Gracias por elegir Omcan



Since 1951 Omcan has grown to become a leading distributor of equipment and supplies to the North American food service industry. Our success over these many years can be attributed to our commitment to strengthen and develop new and existing relationships with our valued customers and manufacturers. Today with partners in North America, Europe, Asia and South America, we continually work to improve and grow the company. We strive to offer customers exceptional value through our qualified local sales and service representatives who provide convenient access to over 6,500 globally sourced products.

Depuis 1951 Omcan a grandi pour devenir un des "leaders" de la distribution des équipements et matériel pour l'industrie des services alimentaires en Amérique du Nord. Notre succès au cours de ces nombreuses années peut être attribué à notre engagement à renforcer et à développer de nouvelles et existantes relations avec nos clients et les fabricants de valeur. Aujourd'hui avec des partenaires en Amérique du Nord, Europe, Asie et Amérique du Sud, nous travaillons continuellement à améliorer et développer l'entreprise. Nous nous efforçons d'offrir à nos clients une valeur exceptionnelle grâce à nos ventes locales qualifiées et des représentants de service qui offrent un accès facile à plus de 6500 produits provenant du monde entier.

Desde 1951 Omcan ha crecido hasta convertirse en un líder en la distribución de equipos y suministros de alimentos en América del Norte industria de servicios. Nuestro éxito en estos años se puede atribuir a nuestro compromiso de fortalecer y desarrollar nuevas relaciones existentes con nuestros valiosos clientes y fabricantes. Hoy con socios de América del Norte, Europa, Asia y América del Sur, que trabajan continuamente para mejorar y crecer la empresa. Nos esforzamos por ofrecer a nuestros clientes valor excepcional a través de nuestro local de ventas y representantes de los servicios que proporcionan un fácil acceso a más de 6,500 productos con origen a nivel mundial.

