

NUF-060-SS

STAINLESS STEEL UNDERCOUNTER FREEZER

Ideal for commercial kitchens, restaurants & cafeterias

NEW AIR



FEATURES

- Dixell™ digital temperature control
- Stainless steel interior and exterior
- Adjustable epoxy-coated wire shelving
- Self-closing doors with stay open feature
- Back mounted compressor
- Heavy duty casters



SPECIFICATIONS

Capacity (Cu. ft)	15.53
Capacity (Liters)	440 L
Exterior Dimensions (in)	60 1/8" x 31 1/2" x 35 7/8"
Interior Dimensions (in)	57" x 27" x 25"
Net Weight (kg/lbs)	104.8 kg / 231 lbs
Door(s)	2
Temperature Range (°C)	-22 TO -17°C
Ambiant Temperature	25°C
Ambiant Humidity	55%
Refrigerant (CFC-Free)	R290
Amperage (A)	8.0 A
Voltage (V)	115V / 60Hz
Plug Type	NEMA 5-15P

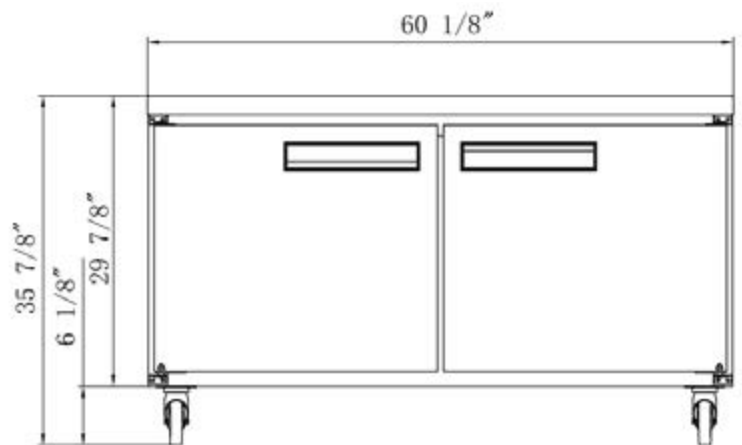
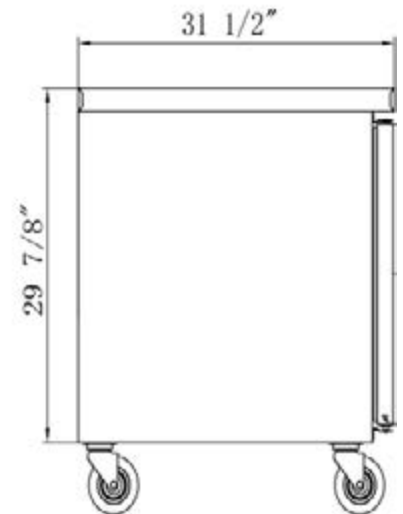

NEW AIR

*Design and specifications may change without prior notice for product improvement

CUSTOMER SUPPORT



1-800-567-3620

NEWAIRREFRIGERATION.CA



2025