

NPT-072-SA

REFRIGERATED SALAD/SANDWICH PREP TABLE

Ideal for restaurants, cafeterias & food processing spaces

NEW AIR



FEATURES

Stainless steel interior and exterior

Rear digital controller

Back mounted compressor

Self-closing doors with stay open feature

Adjustable heavy duty shelves

Clear plastic 1/6 pans included



14.5" deep cutting board



SPECIFICATIONS

Capacity (Cu. ft)	17.58
Capacity (Liters)	497.81 L
Exterior Dimensions (in)	72 1/2" x 33 1/8" x 43 5/8"
Interior Dimensions (in)	68" x 20" x 23"
Net Weight (kg/lbs)	154.7 kg / 341 lbs
Door(s)	3
Temperature Range (°C)	0.5 TO 5°C
Ambiant Temperature	25°C
Ambiant Humidity	55%
Refrigerant (CFC-Free)	R290
Amperage (A)	3.4 A
Voltage (V)	115V / 60Hz
Plug Type	NEMA 5-15P

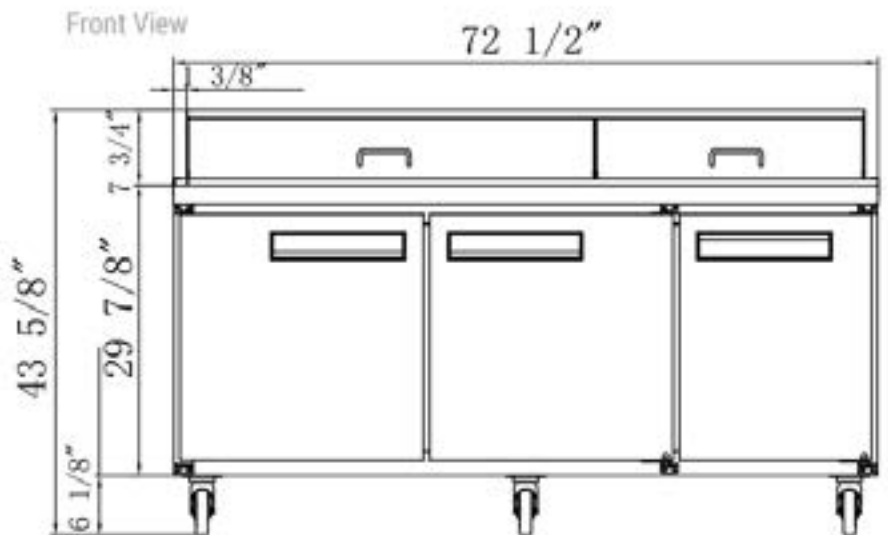
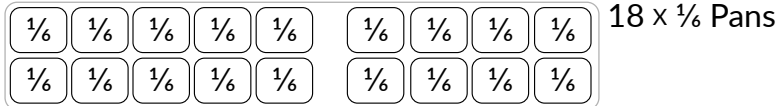
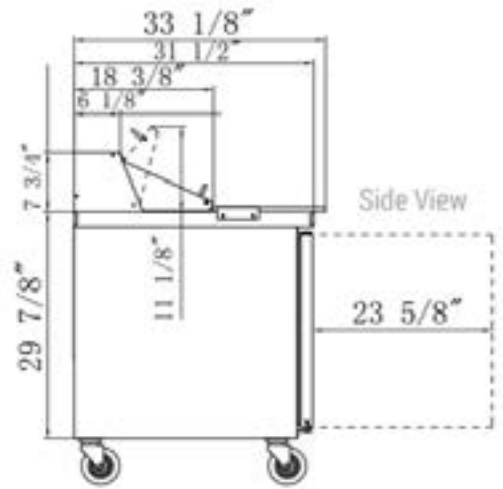

*Design and specifications may change without prior notice for product improvement

CUSTOMER SUPPORT



1-800-567-3620



NEWAIRREFRIGERATION.CA

