

NPT-070-PI



REFRIGERATED PIZZA PREP TABLE

Ideal for restaurants, cafeterias & food processing spaces



FEATURES

Stainless steel interior and exterior

Front digital controller

High quality condenser with higher dust resistance

Self-closing doors with stay open feature

Adjustable heavy duty shelves

Clear plastic 1/3 pans included



19" deep cutting board



SPECIFICATIONS

| | |
|--------------------------|-------------------------|
| Capacity (Cu. ft) | 17.58 |
| Capacity (Liters) | 497.81 L |
| Exterior Dimensions (in) | 70" × 35 3/8" × 43 7/8" |
| Interior Dimensions (in) | 48 1/2" × 25" × 23" |
| Net Weight (kg/lbs) | 134.6 kg / 297 lbs |
| Door(s) | 2 |
| Temperature Range (°C) | 0.5 TO 5°C |
| Ambiant Temperature | 25°C |
| Ambiant Humidity | 55% |
| Refrigerant (CFC-Free) | R290 |
| Amperage (A) | 2.8 A |
| Voltage (V) | 115V / 60Hz |
| Plug Type | NEMA 5-15P |

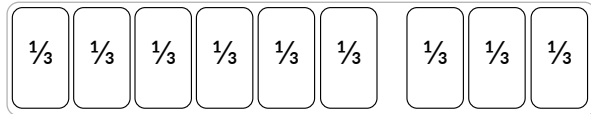
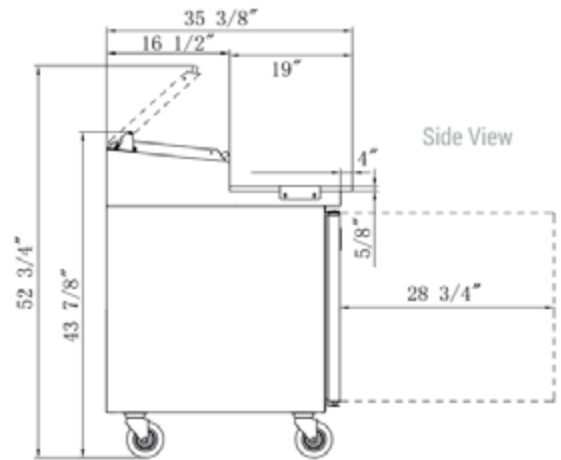

9 x 1/3 Pans



Front View

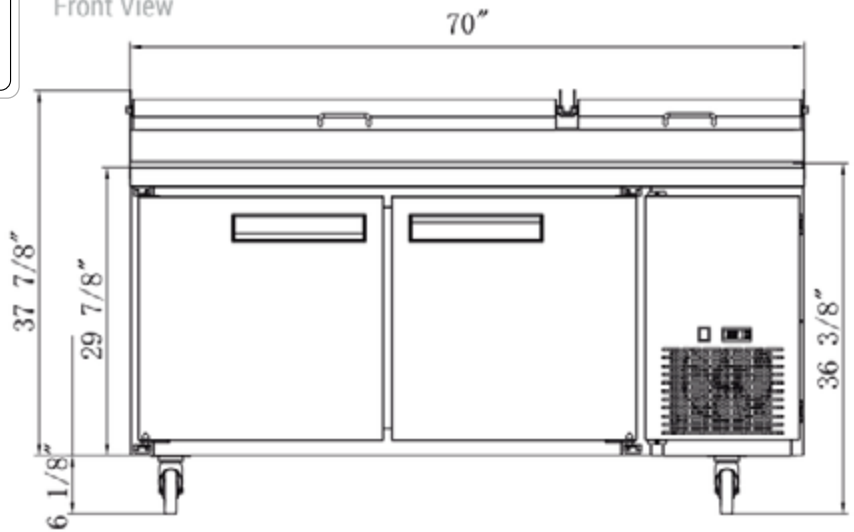

*Design and specifications may change without prior notice for product improvement

CUSTOMER SUPPORT



1-800-567-3620



NEWAIRREFRIGERATION.CA

