

NPT-048-MSA



REFRIGERATED SALAD/SANDWICH PREP TABLE

Ideal for restaurants, cafeterias & food processing spaces



FEATURES

Stainless steel interior and exterior

Rear digital controller

Back mounted compressor

Self-closing doors with stay open feature

Adjustable heavy duty shelves

Clear plastic 1/6 pans included



9" deep cutting board



SPECIFICATIONS

Capacity (Cu. ft)	11.47
Capacity (Liters)	324.79 L
Exterior Dimensions (in)	48 1/4" x 34 5/8" x 45 3/4"
Interior Dimensions (in)	44" x 20" x 23"
Net Weight (kg/lbs)	104.8 kg / 231 lbs
Door(s)	2
Temperature Range (°C)	0.5 TO 5°C
Ambiant Temperature	25°C
Ambiant Humidity	55%
Refrigerant (CFC-Free)	R290
Amperage (A)	2.4 A
Voltage (V)	115V / 60Hz
Plug Type	NEMA 5-15P

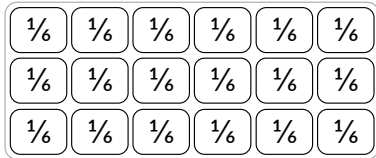
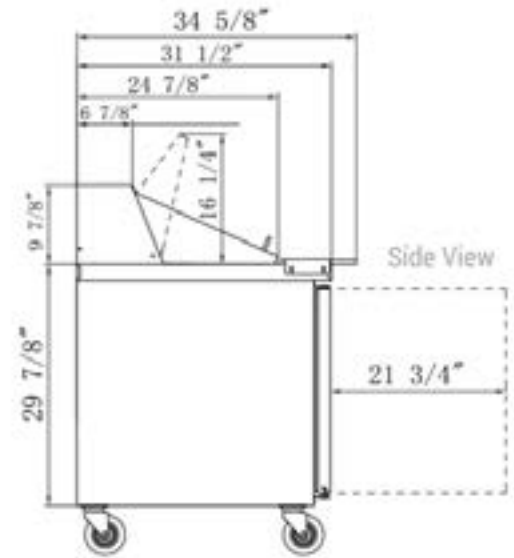

18 x 1/8" Pans

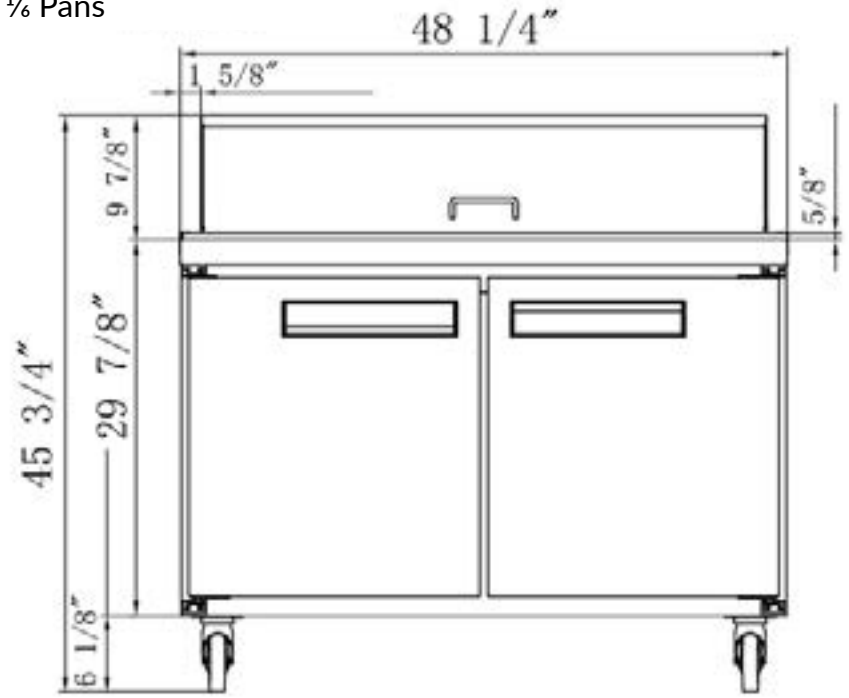

*Design and specifications may change without prior notice for product improvement

CUSTOMER SUPPORT



1-800-567-3620



NEWAIRREFRIGERATION.CA

