

NOM-48-HTS

HEATED GRAB N' GO

OPEN MERCHANDISER - MEDIUM PROFILE

Ideal for restaurants, cafés, convenience stores and groceries

NEW AIR



FEATURES

Warm toned LED above & under each shelf

Pull-down night curtain

Adjustable shelves

Double-pane tempered glass

Front-facing condenser with easy-to-clean filter

Black brushed stainless steel exterior

Price tag channel

Digital temperature controls
with separate light switch

SPECIFICATIONS



| | |
|--------------------------|-----------------------------|
| Capacity (Cu. ft) | 9.11 |
| Capacity (Liters) | 258 L |
| Exterior Dimensions (in) | 47 1/4" x 33 1/2" x 53 1/2" |
| Interior Dimensions (in) | 43 1/4" x 23" x 28" |
| Nbr of Shelves | 2 + base |
| Temperature Range (°C) | 65°C TO 71°C |
| Ambiant Temperature | ≤ 30°C |
| Ambiant Humidity | ≤ 55% |
| Amperage (A) | 13.7A - 15.8A |
| Voltage (V) | 208V - 240V / 60Hz |
| Plug Type | NEMA 6-30P |

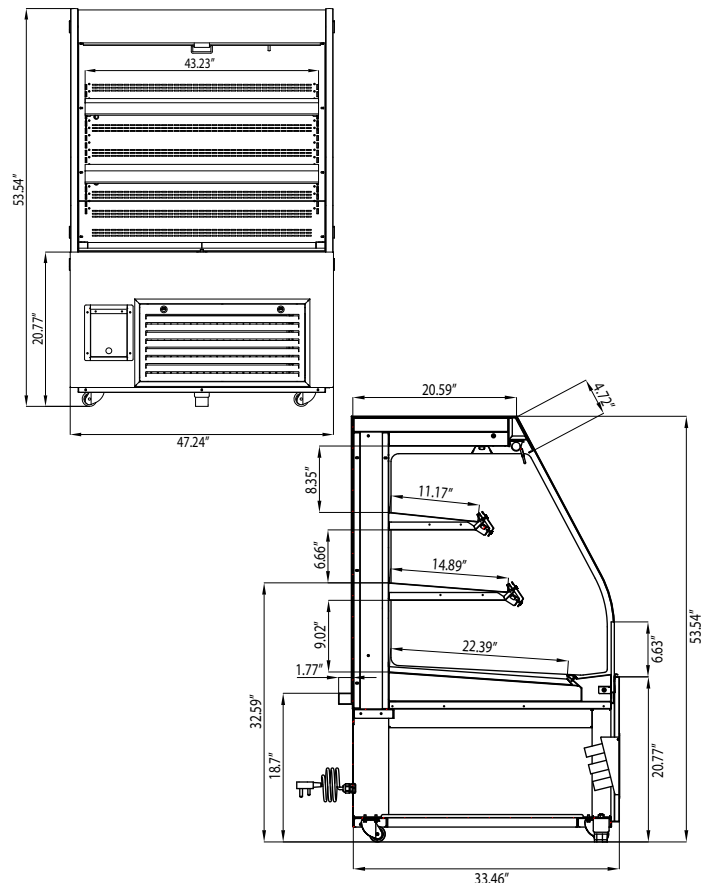

NEW AIR

*Design and specifications may change without prior notice for product improvement

CUSTOMER SUPPORT



1-800-567-3620

NEWAIRREFRIGERATION.CA



2025