

# NOM-36-LSB

## GRAB N' GO REFRIGERATED OPEN MERCHANDISER - LOW PROFILE

Ideal for restaurants, cafés, convenience stores and groceries



### FEATURES

- Cool toned LED at top of the unit
- Pull-down night curtain
- Double-pane tempered glass
- Front-facing condenser with easy-to-clean filter
- Black brushed stainless steel exterior
- Digital temperature controls with separate light switch

### SPECIFICATIONS



Capacity (Cu. ft)	5.08
Capacity (Liters)	144
Exterior Dimensions (in)	35 1/2" x 35 3/4" x 41 3/8"
Interior Dimensions (in)	32 1/4" x 28" x 16"
Temperature Range (°C)	2°C TO 5°C
Ambiant Temperature	≤ 30°C
Ambiant Humidity	≤ 55%
Amperage (A)	7.8A
Voltage (V)	115V/60Hz
Plug Type	NEMA 5-15P

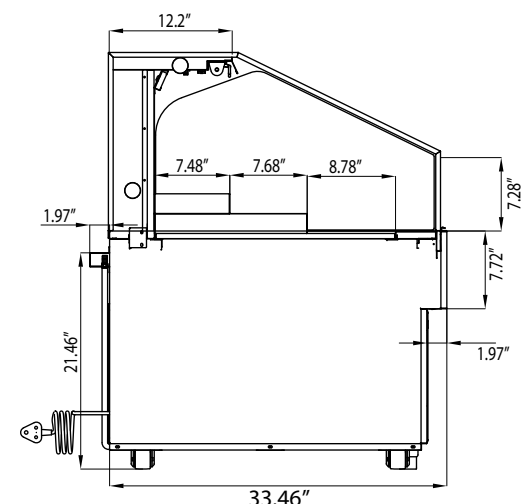
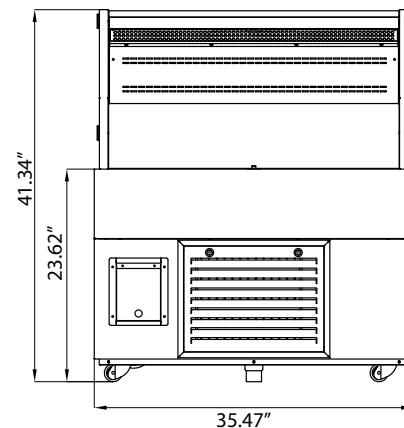

\*Design and specifications may change without prior notice for product improvement

CUSTOMER SUPPORT



1-800-567-3620



NEWAIRREFRIGERATION.CA

