

NDC-36-SG

SQUARE GLASS REFRIGERATED DISPLAY CASE

Ideal for restaurants, cafés & bakeries



FEATURES

Front heated anti-fog film to prevent condensation

Black-brushed stainless steel

Height & angle can be adjusted for each glass shelf

Bright LED lighting under each shelf

Rear digital temperature controller and LED display

Casters

SPECIFICATIONS



Capacity (Cu. ft)	14.7
Capacity (Liters)	417
Exterior Dimensions (in)	35 1/2" x 29 1/4" x 53 1/2"
Interior Dimensions (in)	30 1/2" x 26 1/4" x 31 1/2"
Nbr of shelves	Two (2)
Temp. Range	2 TO 5°C
Refrigerant (CFC-Free)	R290
Amperage (A)	7.6A
Voltage (V)	115V/60Hz
Plug Type	NEMA 5-15P

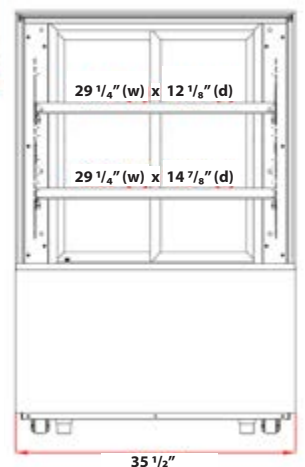
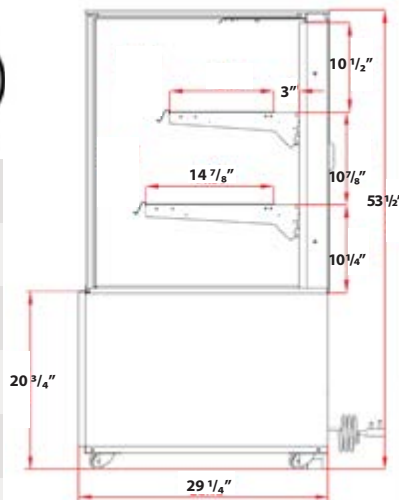

CUSTOMER SUPPORT



1-800-567-3620



NEWAIRREFRIGERATION.CA



*Design and specifications may change without prior notice for product improvement