

RV1  
**NCB-052-SS**  
**REFRIGERATED**  
**CHEF BASE**

Ideal for restaurants, cafeterias & food processing spaces



## FEATURES

Stainless steel exterior & interior with rounded corners for easy cleaning



Digital temperature control & defrost frequency

Heavy duty casters (with front brakes)



Durable & high weight bearing rails for drawers

Removable drawers

## SPECIFICATIONS

Exterior Dimensions (in)	52 1/2" x 32 1/4" x 26 5/8"
Package Dimensions (in)	54 1/8" x 34 1/4" x 29 1/8"
Net Weight (kg/lbs)	109.77 kg / 242 lbs
Drawers	2
Temperature Range (°C)	0.5 TO 3°C
Refrigerant (CFC-Free)	R290
Amperage (A)	2.09 A
Voltage (V)	115V / 60Hz
Plug Type	NEMA 5-15P

### DRAWER LAYOUT OPTIONS

Pans NOT included

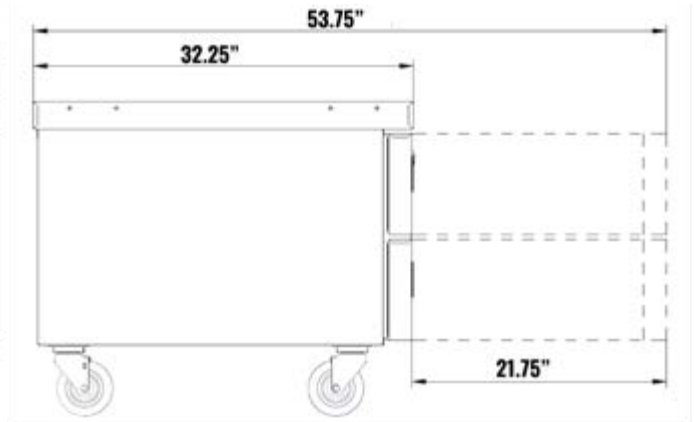
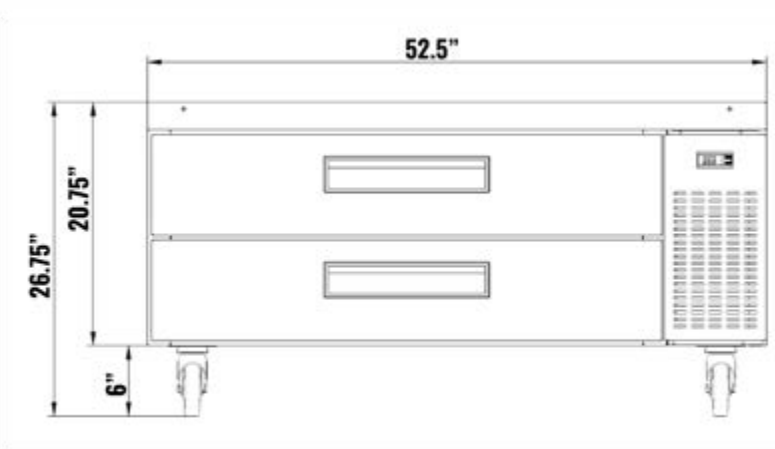
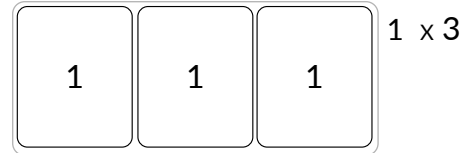
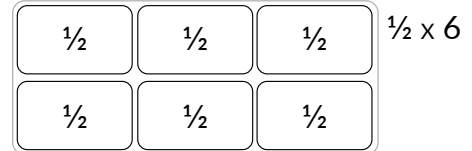
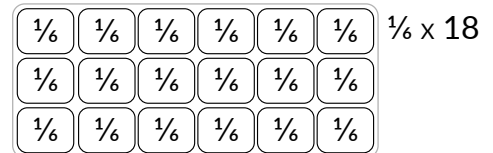

\*Design and specifications may change without prior notice for product improvement

CUSTOMER SUPPORT



1-800-567-3620

NEWAIRREFRIGERATION.CA

