

ITEM #



ELECTRIC Series

Electric Oven, Metal Exterior, Square

ELMS68-32

In the tradition of quality and workmanship established by our acclaimed wood-fired and coal-fired brick ovens, Marra Forni offers a line of electrically heated ovens in a variety of sizes and configurations, including both countertop and larger capacity freestanding models. Each model features our unique Marra Stone® stone-hearth cooking surface as its heart, with its proprietary refractory brick surface which includes volcanic material to consistently maintain cooking temperatures. Insulated construction allows heat to be absorbed and retained in the oven cavity for improved efficiency. The oven is operated by a MarraSmart® fully-programmable digital touchscreen controller, with individually-adjustable upper and lower temperatures, to maximize thermal control for ideal baking results.

With several sizes and configurations to meet a variety of capacity needs, and an extended cooking temperature range between 200-950°F (93-510°C), these powerhouse ovens are efficient and productive for a variety of menu application and cooking techniques.

The “Electric Metal Square” (ELMS) freestanding model offers the cooking performance of a traditional brick pizza oven with the convenience of electric heating, as well as an easy-to-clean flush stainless steel exterior. The ELMS68-32 oven maintains the level of quality, innovation and engineering excellence expected from the Marra Forni name.



Standard Features

- MarraStone® stone hearth deck is of a refractory brick that includes volcanic material. This deck is both durable and highly porous, and is capable of maintaining cooking temperatures up to 950°F (510°C) for consistent high-volume production
- MarraSmart® digital touch screen control technology is fully programmable and provides complete control of oven cooking conditions, as well as automatic timed on/off with menu selection and QR code scanning for maintenance videos. Individual controls permit each oven to be controlled independently, with individual programs if desired
- Highly efficient upper and lower radiant infrared heaters ensure deck and chamber temperature consistency
- 200-950°F (93-510°C) cooking temperature range
- 5-1/2" (142mm) door height opening
- Removable oven door
- Standard interior lighting
- Stainless steel oven exterior
- Galvanneal metal interior walls and ceiling
- 1-1/4" (32mm)-thick black granite mantle ledge
- Matte black steel stand
- Manufactured in the U.S.A.

Cooking Capacity (typical)

- 8" (200mm) pizzas: 24
- 10" (250mm) pizzas: 18
- 12" (300mm) pizzas: 10
- 16" (400mm) pizzas: 7

Production capacity varies depending upon type of food product being cooked, food preparation and set temperature.

Total Cooking Surface 15.11 sq. ft. (1.40 sq. m)

Cooking Deck Dimensions 68 x 32" (1727 x 813mm)



UL 197 | CSA C22.2 No. 109 | NSF/ANSI 4

Configuration Options (Check all that apply)

Options

- Direct Ventilation (quoted separately)
Note: requires Exhaust Fan option
- Exhaust Fan with Variable Speed Fan Control
- Integrated Fan Interlock
- Stainless Steel Stand
- Side Panel Enclosure
- Full Skirt Enclosure

Accessories

- Dough Tray
- Dough Tray Lid(s)
- Dough Tray Dolly
- Standard Peel Tool Kit
- Deluxe Peel Tool Kit
- Wall Mounted Tool Rack

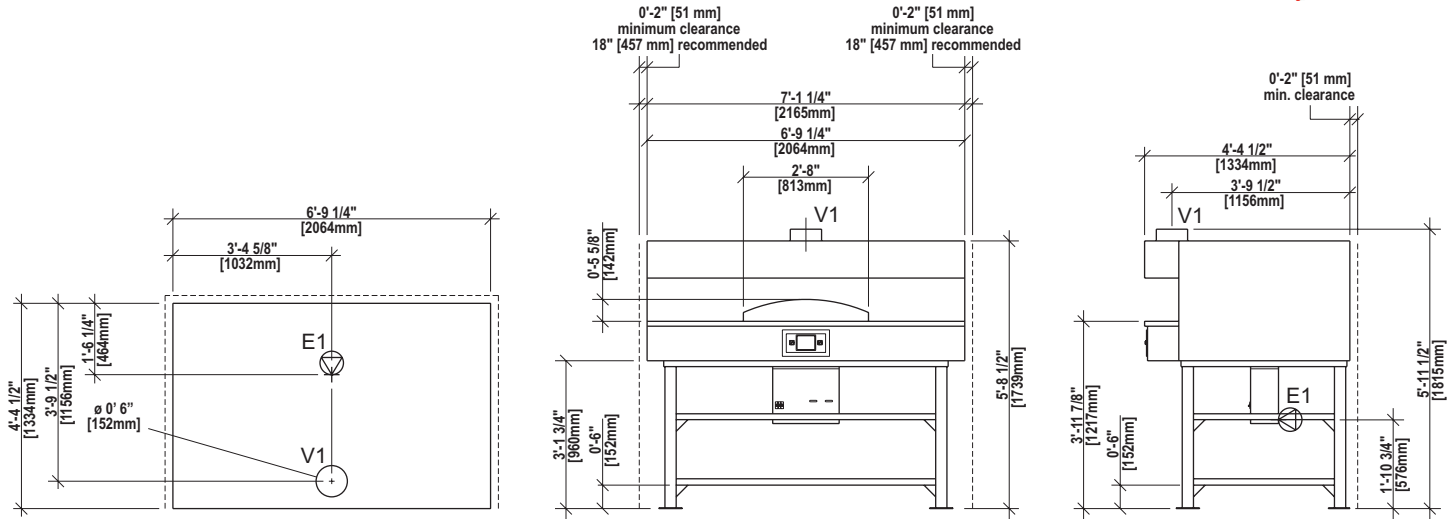

 **Electrical connection(s)**
Strain relief provided for access to internal terminal block. Direct flexible connection to be provided by others.

V1 Ventilation connection
Direct venting, if used, also requires exhaust fan option with variable speed fan control.

Electrical Connection Requirements

Electrical supply	Electrical power rating	Peak load ampacity	Min. supply ampacity	Max. breaker/disconnect
208-240V 50/60 Hz, 3Ph	18.1 kW	50A	70A	70A
380-450V 50/60 Hz, 3Ph	18.1 kW	29A	40A	40A

Ventilation Connection Requirements

Connection	Volume	Static Pressure
8" (203mm) round collar	150 CFM 255 m ³ h	0.01" W.C. 2.5 Pa

Oven may be installed with an approved direct vent system, or under a Type 1 exhaust hood system. Ventilation system must comply with all applicable local and national codes.

Dimensional Information

- Minimum clearance: 2" (51mm) on all sides and rear from combustible surfaces, 0" (0mm) from non-combustible surfaces. 18" (450mm) side clearance recommended for service access
- Exterior: (H x W x D): 71-1/2" x 85-1/4" x 52-1/2" (1815 x 2165 x 1334mm)
- Shipping: (H x W x D): 83" x 87" x 73" (2108 x 2210 x 1854mm)
- Weight: 3,200 lbs. (1451 kg)
- Crated Weight: 3,700 lbs. (1678 kg)
- Freight Class: 77.5, shipped LTL

If direct ventilation is desired, a Marra Forni-designed optional powered vent system is available, and is strongly recommended. This option also requires the exhaust fan (with variable speed fan control) option.

If not using a Marra Forni-supplied direct ventilation connection, determining correct ventilation and code compliance is the responsibility of others.

Specification

ELMS68-32 Item # _____

Unit will be an ETL-listed Marra Forni ELMS68-32 freestanding oven, intended for cooking and baking pizza and other approved food products.

Operating voltage will be: _____ 208-240V, 60Hz, 3Ph.
_____ 380-450V, 60Hz, 3Ph.

Unit will feature a stone hearth cooking deck composed of a unique refractory brick composition, including volcanic material, to provide and maintain cooking temperatures up to 950°F (510°C).

Unit will feature a programmable electronic controller with individually-adjustable upper and lower temperatures, selectable menus, and timed on/off features to accommodate a variety of cooking requirements.

Unit cooking area will measure 68" W x 32" D (1727 x 813mm). Front loading opening will measure 5-1/2" (432mm) in height.

Heating to be accomplished by upper and lower radiant infrared electric heating elements.

Unit will include a removable front door.

Unit will include interior lighting for full-time monitoring of the cooking process.

Unit exterior will be finished in stainless steel, with galvanneal interior.

Unit will include a steel stand for freestanding installation.

Unit will be manufactured in the U.S.A. and comply with all applicable FTC requirements for this status.

All specifications are subject to change without notice, based on Marra Forni's commitment to ongoing product development and improvement measures. Ovens are designed only for the cooking of manufacturer-approved food products in commercial and institutional settings, and should not be used for any other purpose.