



arctic pure

Filter Cartridges

K00540 | K00541 | K00542

FOR USE IN

- ▶ K00540: AR-10000†
- ▶ K00541: AR-20000†
- ▶ K00541: AR-40000† (2 cartridges)
- ▶ K00542: AR-PRE†

REPLACEMENT INSTRUCTIONS

Installation

1. Insert cartridge into head
2. Twist 1/4-turn to the right until it stops

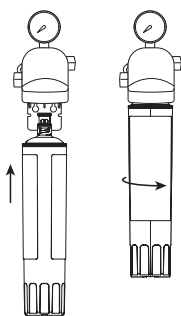

Removal

1. Twist 1/4-turn to the left until it stops
2. Pull cartridge down

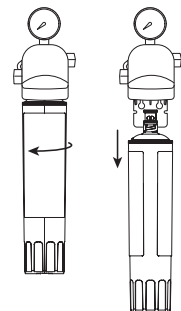

CARTRIDGE DESCRIPTION

The Arctic Pure water filter cartridges are designed to inhibit scale and reduce chlorine, taste, odor, dirt and particulate to 5 microns*. Replacement cartridges are available in two capacities: up to 10,000 gallons (AR-10000) and 20,000 gallons (AR-20000)* These features are designed to support reliable, long-lasting machine performance and great-tasting ice.

FEATURES | BENEFITS

- ▶ Built-in scale inhibitor helps protect against scale formation on equipment surfaces.*
- ▶ Proprietary media filter provides dirt holding capacity and fine sediment reduction.*
- ▶ Reduces chlorine, taste and odor.*
- ▶ Sanitary quick-change filter cartridge design minimizes contamination of filter media during filter cartridge change-out.
- ▶ The optional AR-PRE prefilter helps extend the life of the primary filter by reducing particulate matter in the water before it reaches the primary filter.*

INSTALLATION TIPS

- ▶ Flush cartridges by running water at full flow through the system for five (5) minutes.
- ▶ To remove cartridge twist 1/4-turn to left and pull down.
- ▶ To install cartridge insert the cartridge into head then twist 1/4-turn to the right.
- ▶ For more details, see the installation, operation, and maintenance guide included with the system.

*As tested by Pentair.

†Not performance tested or certified by NSF.

ARCTIC PURE SPECIFICATION SHEET

Filter Cartridges

K00540 | K00541 | K00542



CARTRIDGE SPECIFICATIONS

OPERATING SPECIFICATIONS

Pressure: 30 – 125 psi (2.1 – 8.6 bar)
Temperature: 35–100°F (1.7–38°C)

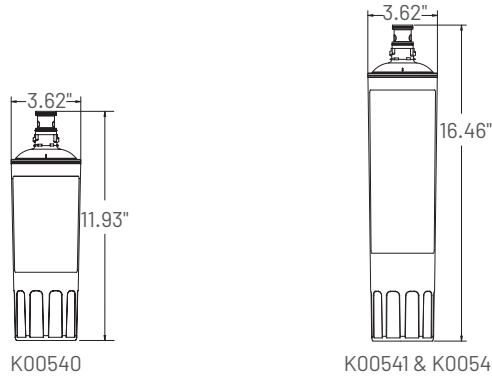

Cartridge Part Number	K00540	K00541	K00542
For System	AR-10000 [†]	AR-20000 [†]	AR-PRE [†]
Dimensions (W x H)	3.62" x 11.93" (9.2 x 27.5 cm)	3.62" x 16.46" (9.2 x 39 cm)	3.62" x 16.46" (9.2 x 39 cm)
Rated Flow	1 gpm (3.8 Lpm)*	1.5 gpm (5.7 Lpm)*	2.5 gpm (9.5 Lpm)*
Chlorine Reduction Capacity	10,000 gal (37,854 L)*	20,000 gal (75,708 L)*	—
Filter Rating	5 micron*	5 micron*	5 micron*
Daily Ice Production	up to 450 lbs (204 kgs)	500 - 900 lbs/day (227 - 408 kgs)	—
Shipping Weight (1PK)	1.8 lbs (0.82 kgs)	2.5 lbs (1.1 kgs)	2.1 lbs (0.95 kg)
Shipping Weight (6PK)	N/A	16.2 lbs (7.3 kgs)	13.5 lbs (6.1 kgs)
Shipping Weight (10PK)	19.4 lbs (8.8 kgs)	N/A	N/A
Chlorine Reduction	Yes*	Yes*	—
Taste & Odor Reduction	Yes*	Yes*	—
Limescale Inhabitation	Yes*	Yes*	—
Particulate Reduction	Yes*	Yes*	Yes*



K00540, K00541, and K00542 are tested and certified by NSF International against NSF/ANSI Standard 42 and CSA B483.1 for material and structural integrity requirements.

COMPONENT

*As tested by Pentair. [†]Not performance tested or certified by NSF.

Replace cartridge when flow rate becomes inconveniently slow or before rated capacity is reached. It is recommended to replace cartridge at least every six (6) months.

Product performance may vary according to flow rate, influent line pressure, and local water conditions

The filter must be protected from freezing. Failure to do so may result in cracking of the filter housing and water leakage.

Do not use with water that is microbiologically unsafe or of unknown quality without adequate disinfection before or after the system.



Pentair Commercial Ice | 2110 South 26th Street | Manitowoc, WI 54220 | United States
+1.920.682.0161 | 920.683.7589 Fax | manitowocice.com

All indicated Pentair trademarks and logos are property of Pentair. Third party registered and unregistered trademarks and logos are the property of their respective owners. ©2025 Pentair. All rights reserved.