

ORACGB

HIGH SPEED OVEN - ALL IN ONE. COMBI WAVE / HIGH SPEED OVEN - STANDARD VERSION
TOTAL PLUG & PLAY - DESIGNED FOR USE ANYWHERE



Features



HIGH SPEED OVEN

An operating mode that simultaneously uses convection, microwave and impingement modes, with temperatures from 100°C to 300°C [212°F to 572°F].



COMBI WAVE

In Combi Wave mode, Oracle can be used as a convection oven with temperatures from 30°C to 300°C [86°F to 572°F], as a microwave oven with power up to 2000W or with a combination of the two cooking methods to achieve results that always exceed expectations.



CONNECTED

Oracle connects free-of-charge to Lainox's Nabook plus portal via the standard- supply Wi-Fi and ethernet features giving you a 4.0 kitchen (find out more on nabookplus.cloud).



OOS - ORACLE ODORLESS SYSTEM

A labyrinth baffle catalyst filter containing platinum particles which help to reduce steam, odours and grease residue during cooking. The Oracle Odorless System does not require any cleaning or routine maintenance work. Its efficiency is always guaranteed.



FAST COOKING SYSTEM

Rely on Lainox's know-how by using the automatic, tried-and-tested recipes for high-speed cooking in High Speed Oven mode.



MICROWAVE COOKING SYSTEM

Rely on Lainox's know-how by using the automatic, tried-and-tested recipes for cooking in Combi Wave mode.



OWB - ORACLE WASHABLE BOX

A special Teflon oven chamber which can be removed and washed for the next round of cooking, making the cleaning procedure fast and cost-effective.

Capacity

Capacity BOOSTED - Steel - 6 kW - 17,9 lt.

Dimensions

Width	<i>mm</i>	467	<i>inch</i>	18.4
Depth	<i>mm</i>	609	<i>inch</i>	24.0
Height	<i>mm</i>	630	<i>inch</i>	24.8
Maximum outer width	<i>mm</i>	467	<i>inch</i>	18.4
Max exterior depth	<i>mm</i>	657	<i>inch</i>	25.9
Maximum exterior height	<i>mm</i>	630	<i>inch</i>	24.8
Packaging width	<i>mm</i>	600	<i>inch</i>	23.6
Packing depth	<i>mm</i>	800	<i>inch</i>	31.5
Packaging height	<i>mm</i>	800	<i>inch</i>	31.5
Weight	<i>kg</i>	63	<i>lbs</i>	138.9
Gross weight	<i>kg</i>	75	<i>lbs</i>	165.4
Volume	<i>m3</i>	0.17917389	<i>ft3</i>	6.3
Packing volume	<i>m3</i>	0.384	<i>ft3</i>	13.6
Cooking compartment width	<i>mm</i>	310	<i>inch</i>	12.2
Cooking compartment depth	<i>mm</i>	320	<i>inch</i>	12.6
Cooking chamber dimensions	<i>mm</i>	180	<i>inch</i>	7.1
Support base width	<i>mm</i>	426	<i>inch</i>	16.8
Base dimensions	<i>mm</i>	510	<i>inch</i>	20.1
Cable length	<i>m</i>	2	<i>ft</i>	6.56

Power supply

Power supply voltage		(1) 3P AC 208 V / (2) 2P AC 208 V / (3) 2P AC 240 V
Consumption	<i>A</i>	(1) 23 / (2) 24 / (3) 23
Frequency	<i>Hz</i>	60
Total electric power	<i>kW</i>	5,3
Microwave	<i>kW</i>	2
Impingement	<i>kW</i>	(1) 3 / (2) 2,2 / (3) 2,2

HOW TO USE

- COMBI WAVE - MCS (MICROWAVE COOKING SYSTEM) AUTOMATIC COOKING SYSTEM FOR ITALIAN AND INTERNATIONAL RECIPES, INCLUDING THE HISTORY, INGREDIENTS, COOKING ACCESSORIES, PROCEDURE AND AUTOMATIC COOKING PROGRAM. - MANUAL MODE WITH THREE INSTANT START COOKING METHODS: CONVECTION, MICROWAVE OR COMBINED CONVECTION + MICROWAVE.
- HIGH SPEED OVEN - FCS (FAST COOKING SYSTEM) AUTOMATIC COOKING SYSTEM FOR ITALIAN AND INTERNATIONAL RECIPES, INCLUDING THE HISTORY, INGREDIENTS, COOKING ACCESSORIES, METHOD AND AUTOMATIC COOKING PROGRAM. - MANUAL MODE WITH INSTANT START
- PROGRAMMABLE MODE: POSSIBILITY OF PROGRAMMING AND STORING A RECIPE WITH ITS COOKING PROCEDURES IN AUTOMATIC SEQUENCE.

CONNECTIVITY BETWEEN NABOO AND LAINOX CLOUD (PATENTED) - WI-FI OR ETHERNET

- AUTOMATIC SOFTWARE UPDATE NOTIFICATION SYSTEM.
- RECIPE CREATION INCLUDING INGREDIENTS WITH PROCEDURE AND PHOTO.
- UPDATE SOFTWARE AUTOMATICALLY AND FOR MULTIPLE DEVICES AT ONCE.
- POSSIBILITY TO DOWNLOAD RECIPES FROM THE NABOOK PLUS PORTAL BASED ON COUNTRY.
- REMOTE DIAGNOSIS VIA NABOOK PLUS PORTAL BY LAINOX SERVICE CENTERS.
- HACCP MONITORING.
- SYNCHRONISATION OF MULTIPLE ORACLE OVENS CONNECTED TO THE SAME ACCOUNT (PATENTED).
- DIRECT ACCESS BY ORACLE TO THE RECIPE DATABASE WITH DOWNLOAD OPTION (PATENTED).
- NABOOK PLUS. YOU CAN ACCESS NABOOK PLUS, THE VIRTUAL COOKING ASSISTANT, THANKS TO ACCESS TO THE CLOUD.
- WI-FI/ETHERNET CONNECTIVITY NABOOK PLUS

CONTROL MECHANISMS

- USB CONNECTION TO DOWNLOAD HACCP DATA, UPDATE SOFTWARE AND UPLOAD/DOWNLOAD COOKING RECIPES.
- POSSIBILITY OF CHOOSING THE FAN SPEED IN COMBI WAVE MODE.
- AUTOMATIC FAN SPEED FOR HIGH SPEED OVEN MODE.

STRUCTURAL CHARACTERISTICS

- PULL-DOWN DOOR WITH ERGONOMIC HANDLE.
- POSSIBILITY OF CHOOSING THE EXTERNAL COLOUR.
- WHEN OPEN, THE DOOR SLIDES UNDER THE COOKING SURFACE OF THE OVEN, ALLOWING THE FOOD TO REMOVED SAFELY WITHOUT THE RISK OF BURNS.
- INTEGRATED CATALYST FILTER FOR OPERATION WITHOUT HOOD.
- PERFECTLY SMOOTH ROOM.
- MADE OF STAINLESS STEEL.

OPERATION

- USER INTERFACE WITH A CHOICE OF 29 LANGUAGES.
- AUTOMATIC RESUMPTION OF COOKING IN CASE OF A POWER FAILURE.
- 7" COLOUR SCREEN (LCD, HIGH DEFINITION, CAPACITIVE, WITH "TOUCH SCREEN" FUNCTIONS).
- ORGANISATION OF RECIPES IN FOLDERS WITH PREVIEW, GIVING EACH FOLDER ITS OWN NAME.
- DISPLAY THAT CAN BE CONFIGURED BASED ON THE USER'S NEEDS, BRINGING FORWARD THE PROGRAMMES USED MOST.
- ORACLE COACH. VIRTUAL ASSISTANT THAT PROVIDES ADVICE ON USING ORACLE AND INFORMS WHEN MAINTENANCE IS NEEDED.
- THERE ARE NUMEROUS RECIPES AVAILABLE IN ORACLE AND A GROWING NUMBER OF ALTERNATIVE ONES ARE AVAILABLE VIA ACCESS TO THE NABOOK PLUS PORTAL. EACH RECIPE HAS BEEN TESTED TO GUARANTEE BEST RESULTS.
- RAPID COOLING OF THE COOKING CHAMBER WITH OPEN DOOR.
- POSSIBILITY OF PREHEATING THE COOKING CHAMBER UP TO 300°C [572°F].
- STARTING AN AUTOMATIC "ONE TOUCH" COOKING.

SAFETY FEATURES

- MAXIMUM EXTERNAL DOOR FRONT TEMPERATURE OF 65°C [149°F].
- SELF-DIAGNOSIS WITH SMART ERROR VIEWING.
- DOOR OPEN/CLOSED ELECTRONIC SENSOR.
- COMPLIANT WITH THE IEC60335-1, IEC60335-2-90 AND EMC INTERNATIONAL STANDARDS.

CLEANING AND MAINTENANCE

- EASY EXTERIOR CLEANING THANKS TO PERFECTLY SMOOTH SURFACES, AND IPX3 WATER JET PROTECTION RATING.
- OWB, ORACLE WASHABLE BOX, SPECIAL REMOVABLE AND WASHABLE BOX CHAMBER.

INSTALLATION AND ENVIRONMENT

- QUALITY ISO 9001 / SAFETY ISO 45001 / ENVIRONMENTAL ISO 14001 CERTIFICATION.
- PRODUCT RECYCLING RATE 90%.
- 100% RECYCLABLE PACKAGING.
- INSTALLATION & ENVIRONMENT

STANDARD EQUIPMENT

- ETHERNET CONNECTION
- COOKING PLATE
- ALUMINIUM PEEL
- ORACLE WASHABLE BOX
- REMOVABLE AND WASHABLE INNER DOOR PROTECTION
- USB CONNECTION
- WI-FI CONNECTION

OPTIONAL TO BE REQUESTED WHEN ORDERING

MPACK: MULTIPACK PACKAGING - 6 PCS MIXED IN A SINGLE PACKAGE - 1200 X 800 X 2170 H - 415 KG - 2.08 M3

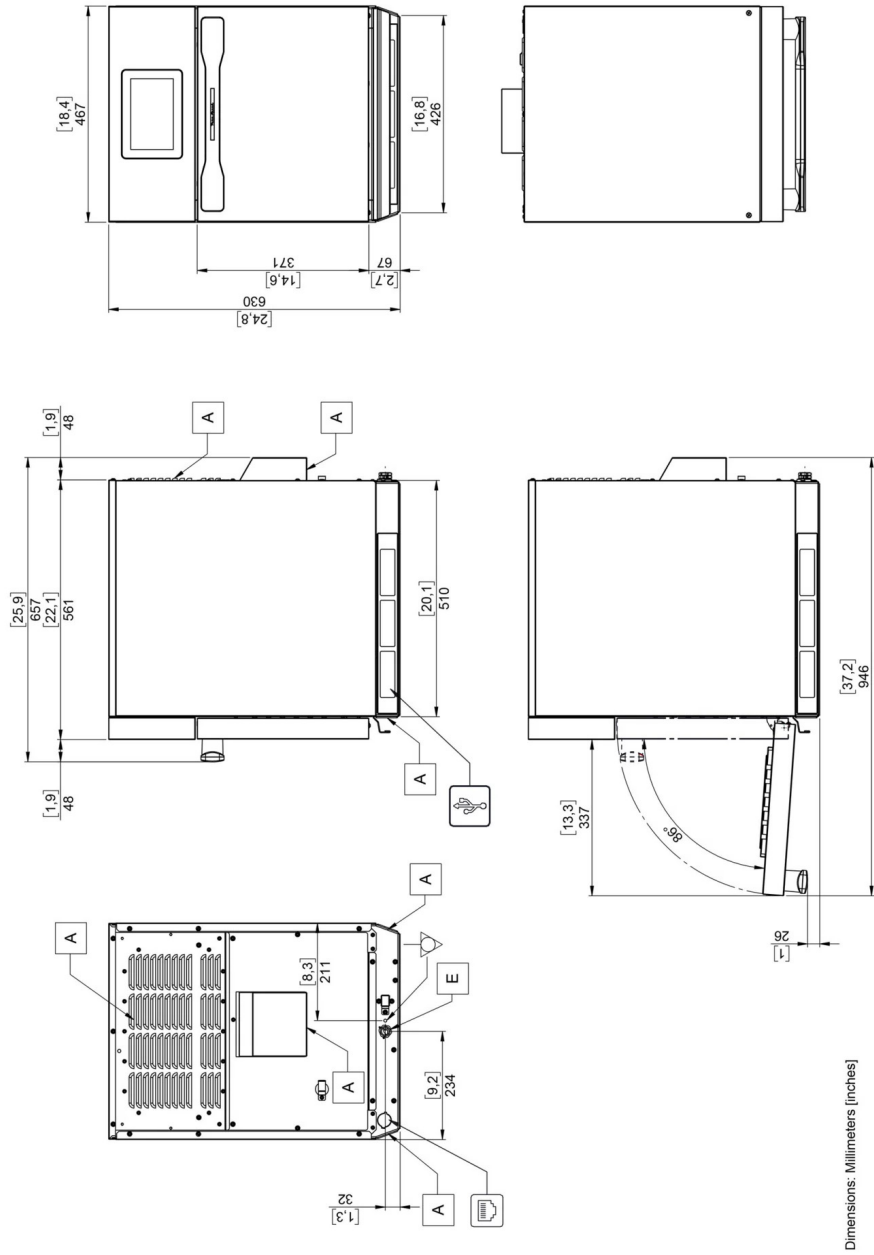

Dimensions: Millimeters [inches]

A	Technical compartment cooling air intake
E	Electric power supply cable inlet
	Ethernet connection
	USB connection

The data reported in this document is to be considered non-binding. The company reserves the right to make changes at any time, without prior notice