



KP0250

Undercounter Ice Cube Machine

KDP0250A | KYP0250A

ICE SHAPES



▶ **Half-Dice:** 3/8" x 1 1/8" x 7/8"
(0.95 x 2.86 x 2.22 cm)



▶ **Dice:** 7/8" x 7/8" x 7/8"
(2.22 x 2.22 x 2.22 cm)

SIZE

- ▶ Up to 228 lbs (103.42 kgs) of daily ice production
- ▶ 26" wide (66 cm), 28.5" (72.4 cm) deep and 38.5" (97.8 cm) high including 6" (15.24 cm) legs
- ▶ 3.4 ft³ (0.096 m³) cabinet volume
- ▶ 80 lbs (36.3 kgs) ice storage capacity*

*Application capacity based on 90% volume x 33 lbs./ft³ average density of ice

SPECIFICATIONS

Refrigerant: R290

- ▶ 4.9 oz (140 g)

BTU Per Hour

- ▶ 3,700 (average)
- ▶ 4,400 (peak)

Operating Limits

- ▶ Ambient temperature range: 40° to 100°F (4.4° to 37.8°C)
- ▶ Water temperature range: 45° to 90°F (4.4° to 32.2°C)
- ▶ Water pressure ice maker (water in)
 - Min. 20 psi (137.9 kPa)
 - Max. 80 psi (551.1 kPa)

Power

115/60/1 ice machines are factory pre-wired with a 6 ft (180 cm) power cord and NEMA 5-15P-plug configuration.

- ▶ Total Amps
 - 7.0 amps
- ▶ Maximum Fuse Size
 - 15 amps
 - HACR-type circuit breakers can be used in place of fuses

ACCESSORIES

- ▶ LuminIce® II Virus and Bacteria Inhibitor helps control viruses and bacteria in the ice machine.
- ▶ Arctic Pure® Water Filters Reduce sediments and chlorine contaminants down to 0.5 microns. Use with a pre-filter is recommended.



LuminIce II



Arctic Pure Water Filters

FEATURES

- ▶ Design & Durability
 - Durable cabinet features a clean, coordinated interior for long-lasting performance.
 - Slide-up bin door design allows unobstructed access for easy use and cleaning.
 - Flat, right-angle plug simplifies installation in tight spaces.
- ▶ Functionality & Innovation
 - Integrated ice maker and bin perfect for small-volume applications.
 - Proprietary vertical evaporator technology engineered in Manitowoc, Wisconsin, for reliable ice production.
- ▶ Performance & Placement
 - R290 refrigerant environmentally responsible and efficient.
 - Compact footprint is ideal for space-constrained environments.
 - Front airflow enables under-counter or adjacent placement.
 - Optional floor-sealing configuration with legs not installed, remains front-serviceable.
- ▶ Sanitation & Maintenance
 - Alphasan® antimicrobial protection is built into key internal components to support extended cleaning intervals.
 - Patented cleaning and sanitizing system helps ensure thorough and efficient maintenance.
 - Simple, tool-free, drop-down access to the air filter.
 - Easy-access air filter is designed for longer operation in greasy or dusty environments.
 - Tool-free filter removal for faster cleaning and greater installation flexibility.
 - Removable, forward-sliding storage bin allows for easy access to refrigeration components for cleaning and maintenance.



Removable Storage Bin



Easy-access air filter

KP0250

Undercounter Ice Cube Machine

KDP0250A | KYP0250A

INSTALLATION

Units to be installed indoors only.

Recommended clearance for top, sides, and back is 5" (127 cm). However, no minimum clearance is required.

- A** 3/8" (0.95 cm) F.P.T. Ice Making Water Inlet
- B** 1/2" (1.27 cm) F.P.T. Ice Making Water Drain
- C** 1/2" (1.27 cm) F.P.T. Bin Drain
- D** Electrical Entrance

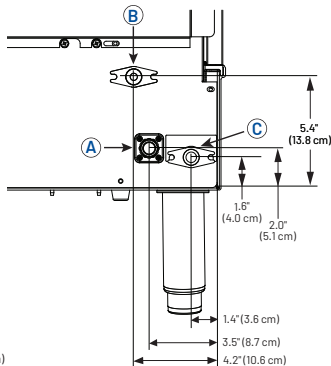
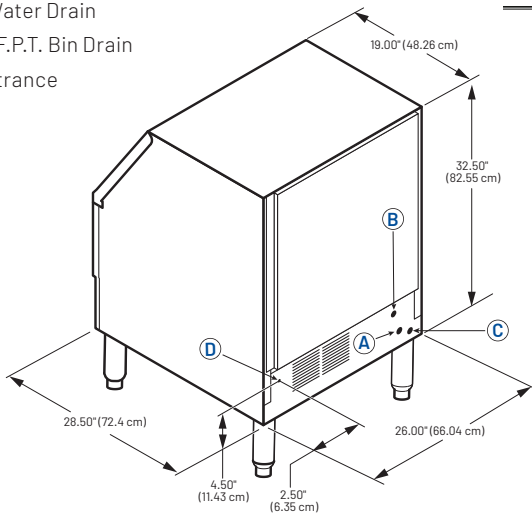

SPACE-SAVING DESIGN



KP0250

Height	38.50" 97.8 cm
Width	26" 66 cm
Depth	28.50" 72.4 cm

Height includes adjustable bin legs 6.00" to 8.00", (15.24 to 20.32 cm) set at 6.00" (15.24 cm).

Ice machine and bin sold separately.

SPECIFICATIONS

	Model	Ice Shape	Shipping Weight	Ice Production 24 Hours		Power Usage kWh per 100 lbs. of ice	Potable water usage gal/100 lbs. ice @ 90° Air/70°F Water (32° Air/21°C Water)
				70° Air/50°F Water 21° Air/10°C Water	90° Air/70°F Water 32° Air/21°C Water		
Air Cooled	KDP0250A	Dice	154 lbs (69.9 kgs)	228 lbs (103.52 kgs)	163 lbs (73.94 kgs)	7.05	15.9 gal (60.19 L)
	KYP0250A	Half-Dice	154 lbs (69.9 kgs)	221 lbs (100.24 kgs)	175 lbs (79.38 kgs)	6.78	15.9 gal (60.19 L)

Standard 6" (15.24 cm) adjustable, flange foot, gray painted legs included. Standard plastic ice scoop included.

Limited Commercial Warranty

Ice Maker Three (3) years parts and labor

Evaporator Five (5) years parts and labor

Compressor Five (5) years parts, three (3) years labor



2110 South 26th Street | Manitowoc, WI 54220 | United States
+1.920.682.0161 | 920.683.7589 Fax | manitowocice.com

All indicated Pentair trademarks and logos are property of Pentair. Third party registered and unregistered trademarks and logos are the property of their respective owners. ©2026 Pentair. All rights reserved.