

# **KOOLAIRE**

► FROM MANITOWOC

## **KP0150 & KP0250 UnderCounter Ice Machines**

### **Installation, Operation and Maintenance Manual**



**⚠ Caution**

Read this instruction before operating this equipment.



# Safety Notices

## Safety Notices

### Read these precautions to prevent personal injury:

- Read this manual thoroughly before operating, installing or performing maintenance on the equipment. Failure to follow instructions in this manual can cause property damage, injury or death.
- Routine adjustments and maintenance procedures outlined in this manual are not covered by the warranty.
- Proper installation, care and maintenance are essential for maximum performance and trouble-free operation of your equipment.  
Visit our website [www.manitowocice.com](http://www.manitowocice.com) for manual updates, translations, or contact information for service agents in your area.
- This equipment contains high voltage electricity and refrigerant charge. Installation and repairs are to be performed by properly trained technicians aware of the dangers of dealing with high voltage electricity and refrigerant under pressure. The technician must also be certified in proper refrigerant handling and servicing procedures. All lockout and tag out procedures must be followed when working on this equipment.
- This equipment is intended for indoor use only. Do not install or operate this equipment in outdoor areas.

## Definitons

### **DANGER**

Indicates a hazardous situation that, if not avoided, will result in death or serious injury. This applies to the most extreme situations.

### **Warning**

Indicates a hazardous situation that, if not avoided, could result in death or serious injury.

### **Caution**

Indicates a hazardous situation that, if not avoided, could result in minor or moderate injury.

### **Notice**

Indicates information considered important, but not hazard-related (e.g. messages relating to property damage).

NOTE: Indicates useful, extra information about the procedure you are performing.

### **⚠ Warning**

#### **Follow these precautions to prevent personal injury during installation of this equipment:**

- Installation must comply with all applicable equipment fire and health codes with the authority having jurisdiction.
- To avoid instability the installation area must be capable of supporting the combined weight of the equipment and product. Additionally the equipment must be level side to side and front to back.
- Ice machines require a deflector when installed on an ice storage bin. Prior to using a non-OEM ice storage system with this ice machine, contact the bin manufacturer to assure their ice deflector is compatible.
- Prior to installing a non-OEM ice storage system with this ice machine, follow the manufacturers installation procedures and verify the location and installation meets the local/national mechanical codes and stability requirements.
- Remove all removable panels before lifting and installing and use appropriate safety equipment during installation and servicing. Two or more people are required to lift or move this appliance to prevent tipping and/or injury. Remove all removable panels before lifting and installing and use appropriate safety equipment during installation and servicing. Two or more people are required to lift or move this appliance to prevent tipping and/or injury.
- Legs or casters must be installed and the legs/casters must be screwed in completely. When casters are installed the mass of this unit will allow it to move uncontrolled on an inclined surface. These units must be tethered/secured to comply with all applicable codes. Swivel casters must be mounted on the front and rigid casters must be mounted on the rear. Lock the front casters after installation is complete.
- Connect to a potable water supply only.
- Do not damage the refrigeration circuit when installing, maintaining or servicing the unit.
- This equipment contains refrigerant charge. Installation of the line sets must be performed by a properly trained and EPA certified refrigeration technician aware of the dangers of dealing with refrigerant charged equipment.

## ⚠ DANGER



Follow these flammable refrigeration system requirements during installation, use or repair of this equipment:

- Refer to nameplate - Ice machine models may contain up to 500 grams of R290(propane) refrigerant. R290 (propane) is flammable in concentrations of air between approximately 2.1% and 9.5%by volume (LEL lower explosion limit and UEL upper explosion limit). An ignition source at a temperature higher than 878°F (470°C) is needed for a combustion to occur. Refer to nameplate to identify the type of refrigerant in your equipment.
- To minimize the risk of ignition due to improper installation, replacement parts or service procedures, only refrigeration technicians with flammable refrigerant training who are aware of the dangers of dealing with high voltage electricity and refrigerant under pressure are allowed to work on this equipment.
- All replacement parts must be like components obtained from the equipment manufacturers authorized replacement part network.
- This equipment must be installed in accordance with the ASHRAE 15 Safety Standard for Refrigeration Systems.
- This equipment can not be installed in corridors or hallways of public buildings.
- Installation must comply with all applicable equipment fire and health codes with the authority having jurisdiction.
- Minimum room size may be required, refer to ice machine label.
- Multiple R290 units can be installed in a single room, but their cumulative refrigerant charge needs to be considered when determining the safe room size.
- All lockout and tag out procedures must be followed when working on this equipment.
- This equipment contains high voltage electricity and refrigerant charge. Shorting electrical wires to refrigeration tubing may result in an explosion. All electrical power must be disconnected from the system before servicing the system. Refrigerant leaks, can result in serious injury or death from explosion, fire, or contact with refrigerant or lubricant mists.
- Do not damage the refrigeration circuit when installing, maintaining or servicing the unit. Never use sharp objects or tools to remove ice or frost. Do not use mechanical devices or other means to accelerate the defrosting process.
- Well-ventilated areas are recommended for installation and storage.
- Leak pressure, leak hole size, wind speed, and the presence of objects like furniture within the room can also affect the concentration and distribution of R290 during a leak.

**⚠ Warning**

**Follow these electrical requirements during installation of this equipment.**

- All field wiring must conform to all applicable codes of the authority having jurisdiction. It is the responsibility of the end user to provide the disconnect means to satisfy local codes. Refer to rating plate for proper voltage.
- This appliance must be grounded.
- This equipment must be positioned so that the plug is accessible unless other means for disconnection from the power supply (e.g., circuit breaker or disconnect switch) is provided.
- Check all wiring connections, including factory terminals, before operation. Connections can become loose during shipment and installation.

**⚠ DANGER**

Do not operate equipment that has been misused, abused, neglected, damaged, or altered/modified from that of original manufactured specifications. This appliance is not intended for use by persons (including children) with reduced physical, sensory or mental capabilities, or lack of experience and knowledge, unless they have been given supervision concerning use of the appliance by a person responsible for their safety. Do not allow children to play with, clean or maintain this appliance without proper supervision.

**⚠ Warning**

**Follow these precautions to prevent personal injury while operating or maintaining this equipment:**

- Read this manual thoroughly before operating, installing or performing maintenance on the equipment. Failure to follow instructions in this manual can cause property damage, injury or death.
- Crush/Pinch Hazard. Keep hands clear of moving components. Components can move without warning unless power is disconnected and all potential energy is removed.
- Moisture collecting on the floor will create a slippery surface. Clean up any water on the floor immediately to prevent a slip hazard.
- Objects placed or dropped in the bin can affect human health and safety. Locate and remove any objects immediately.
- Never use sharp objects or tools to remove ice or frost. Do not use mechanical devices or other means to accelerate the defrosting process.
- When using cleaning fluids or chemicals, rubber gloves and eye protection (and/or face shield) must be worn.

**⚠ Warning**

Temporary electrical installations of more than 600 volts may be used only during periods of tests, emergencies, or construction-like activities.

Temporary wiring must be removed immediately upon completion of the project or purpose for which the wiring was installed.

**⚠ DANGER**

**Follow these precautions to prevent personal injury during use and maintenance of this equipment:**

- It is the responsibility of the equipment owner to perform a Personal Protective Equipment Hazard Assessment to ensure adequate protection during maintenance procedures.
- Do Not Store Or Use Gasoline Or Other Flammable Vapors Or Liquids In The Vicinity Of This Or Any Other Appliance. Never use flammable oil soaked cloths or combustible cleaning solutions for cleaning.
- All covers and access panels must be in place and properly secured when operating this equipment.
- Risk of fire/shock. All minimum clearances must be maintained. Do not obstruct vents or openings.
- Failure to disconnect power at the main power supply disconnect could result in serious injury or death. The power switch DOES NOT disconnect all incoming power.
- All utility connections and fixtures must be maintained in accordance with the authority having jurisdiction.
- Turn off and lockout all utilities (gas, electric, water) according to approved practices during maintenance or servicing.
- Units with power cords must be plugged into individual branch circuits. During movement, cleaning or repair it is necessary to unplug both power cords.
- Never use a high-pressure water jet for cleaning on the interior or exterior of this unit. Do not use power cleaning equipment, steel wool, scrapers or wire brushes on stainless steel or painted surfaces.
- Two or more people are required to move this equipment to prevent tipping.
- Locking the front casters after moving is the owner's and operator's responsibility. When casters are installed, the mass of this unit will allow it to move uncontrolled on an inclined surface. These units must be tethered/secured to comply with all applicable codes.
- The on-site supervisor is responsible for ensuring that operators are made aware of the inherent dangers of operating this equipment.
- Do not operate any appliance with a damaged cord or plug. All repairs must be performed by a qualified service company.
- Do not store or use electrical appliances inside the ice machine or ice storage areas.

# Table of Contents

---

## Safety Notices

<b>Safety Notices</b> .....	<b>4</b>
<b>Definitons</b> .....	<b>4</b>

## Section 1 General Information

<b>Model Numbers</b> .....	<b>11</b>
Shipping Weight .....	11
<b>Machine Preparation</b> .....	<b>11</b>
How to read a model number .....	11
<b>Accessories</b> .....	<b>12</b>
Bin Caster .....	12
Arctic Pure Water Filter system .....	12
Manitowoc De-scaler and Sanitizer .....	12
LuminIce® .....	12
<b>Warranty</b> .....	<b>12</b>
Warranty Registration .....	12

## Section 2 Installation

<b>Location of Ice Machine</b> .....	<b>13</b>
<b>Installation Requirements</b> .....	<b>13</b>
<b>Minimum Cut-Out For Built-In Installations</b> .....	<b>13</b>
<b>Heat of Rejection</b> .....	<b>14</b>
Leveling the Ice Machine.....	14
<b>Electrical Service</b> .....	<b>14</b>
Electrical Requirements .....	14
Voltage .....	14
Fuse/Circuit Breaker .....	14
Total Circuit Ampacity .....	15
Ground Fault Circuit Interrupter .....	15
Maximum Breaker Size & Total Amperage Chart .....	15
<b>Water Supply and Drain Line Requirements</b> .....	<b>16</b>
WATER CONNECTIONS.....	16
DRAIN CONNECTIONS .....	16
Water Supply.....	16
Water Inlet Lines .....	16
Cooling Tower Applications.....	16
Water Supply & Drain Line Sizing Connections.....	17
<b>Ice Thickness Adjustment</b> .....	<b>18</b>
<b>Refrigerant Charge</b> .....	<b>18</b>
<b>Starting the Ice Machine</b> .....	<b>18</b>
Installation Checklist .....	18

## Section 3 Operation

<b>Touch Pad Features</b> .....	<b>19</b>
<b>Ice Making Sequence of Operation</b> .....	<b>20</b>
Service Limits.....	20

**Section 4  
Maintenance**

<b>De-scaling and Sanitizing</b> .....	<b>21</b>
General.....	21
Detailed De-scaling/Sanitizing Procedure .....	21
Remedial De-scaling Procedure.....	21
<b>Detailed De-scaling and Sanitizing Procedure</b> .....	<b>21</b>
De-scaling Procedure.....	21
Sanitizing Procedure .....	22
Remove Parts for De-scaling or Sanitizing .....	23
<b>Remedial De-scaling</b> .....	<b>24</b>
<b>Ice Machine Inspection</b> .....	<b>24</b>
<b>Exterior Cleaning</b> .....	<b>24</b>
<b>LuminIce® Bulb Maintenance</b> .....	<b>24</b>
BULB REPLACEMENT .....	24
CLEAN-UP PROCEDURE.....	24
<b>Cleaning the Air Condenser Filter</b> .....	<b>24</b>
<b>Cleaning the Air Condenser</b> .....	<b>24</b>
<b>Bin Removal</b> .....	<b>25</b>
<b>Removal from Service/Winterization</b> .....	<b>25</b>
GENERAL.....	25

**Section 5  
Troubleshooting**

<b>Checklist</b> .....	<b>27</b>
<b>Service Limit Feature</b> .....	<b>28</b>

# Section 1

## General Information

---

### Model Numbers

This manual covers the following models:

Self-Contained Air-Cooled	Self-Contained Water-Cooled
KDP0150A	--
KYP0150A	--
KDP0250A	--
KYP0250A	--

### SHIPPING WEIGHT

Model Family	Shipping Weight
KP0150	153 lbs (69 kg)
KP0250	160 lbs (73 kg)

### Machine Preparation

- Before moving the unit into position, secure the door closed and protect any finished flooring.
- Remove and recycle packing materials. Do not discard any hardware.
- Use an appliance dolly to move the unit near the opening.

NOTE: If the unit has been on its back or side, it must stand upright for a minimum of 24 hours before connecting power.

### HOW TO READ A MODEL NUMBER

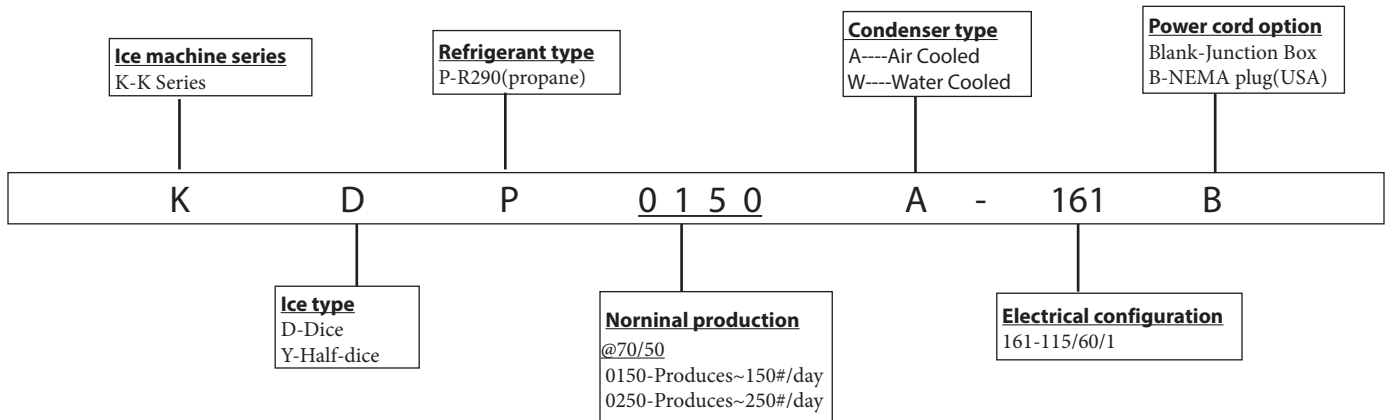

NOTE: These products are hermetically sealed and contain R290 gas.

**Accessories**

Contact your Koolaire distributor for replacement parts for accessories.

**BIN CASTER**

Replaces standard legs.

**ARCTIC PURE WATER FILTER SYSTEM**

Engineered specifically for Koolaire ice machines, Arctic Pure water filters are an efficient, dependable, and affordable method of inhibiting scale formation, filtering sediment, and removing chlorine taste and odor.

**MANITOWOC DE-SCALER AND SANITIZER**

Manitowoc Ice Machine de-scaler and Sanitizer are available in convenient 16 oz. (473 ml) and 1 gal (3.78 l) bottles. These are the only solutions approved for use with Koolaire products.

De-scaler PN.	Sanitizer PN.
16 oz. 9405463	16 oz. 9405653
1 gal. 9405803	1 gal. 9405813

**LUMINICE®**

The LuminIce™ growth inhibitor recirculates the air in the ice machine foodzone over a UV bulb. This process will inhibit the growth of common micro-organisms on all exposed foodzone surfaces.

Replacement Luminice II Bulb: K00528 (includes bulb & additional instructions).

NOTE: LuminIce® bulbs require replacement on a yearly basis.

**Cleanup Procedure for Accidental Bulb Breakage**

The cleanup procedure is identical to the procedure used to clean up compact fluorescent (CFL) or fluorescent tube lights. These lights contain a small amount of mercury sealed within a glass tube. Breaking these types of lights will release mercury and mercury vapor. The broken bulb can continue to release mercury vapor until it is cleaned up and removed.

The latest EPA procedures can be viewed on their website at [www.epa.gov/cfl/cflcleanup.html](http://www.epa.gov/cfl/cflcleanup.html).

**Warranty**

For warranty information visit:  
[www.manitowocice.com/Service/Warranty](http://www.manitowocice.com/Service/Warranty)

- Warranty Coverage Information
- Warranty Registration
- Warranty Verification

Warranty coverage begins the day the ice machine is installed.

**WARRANTY REGISTRATION**

Completing the warranty registration process is a quick and easy way to protect your investment. Scan the QR code with your smart device or enter the link in a web browser to complete your warranty registration.

[WWW.MANITOWOCICE.COM/SERVICE/WARRANTY#WARRANTY-REGISTRATION](http://WWW.MANITOWOCICE.COM/SERVICE/WARRANTY#WARRANTY-REGISTRATION)

Registering your product insures warranty coverage and streamlines the process if any warranty work is required.



*To obtain a printed copy of warranty terms, please contact Manitowoc Ice at 800-545-5720.*

# Section 2 Installation

## Location of Ice Machine

The location selected for the ice machine must meet the following criteria. If any of these criteria are not met, select another location.

- The location must be indoors.
- The location must be free of airborne and other contaminants.
- The air temperature must be at least 40°F (4°C), but must not exceed 100°F (38°C).
- The location must not be near heat-generating equipment or in direct sunlight and protected from weather.
- The location must be capable of supporting the weight of the ice machine and a full bin of ice.
- The location must allow enough clearance for water, drain and electrical connections in the rear of the ice machine.
- The location must not obstruct airflow through or around the ice machine (condenser airflow is in and out the front). Refer to the chart below for clearance requirements.
- The location must not be near garbage or other contaminants.
- Minimum room size required, refer to ice machine label.
- The ice machine must use legs or be sealed to the floor. Before sealing to the floor, the rubber bumpers on the bottom of the ice machine must be removed.

Location	Self-Contained Air-Cooled	Self-Contained Water-Cooled
Top/Sides	5 (127 mm)	5 (127 mm)
Back	5 (127 mm)	5 (127 mm)

NOTE: The ice machine may be built into a cabinet. There is no minimum clearance requirement for the top or left and right sides of the ice machine. The listed values are recommended for efficient operation and servicing only.

## Installation Requirements

- The ice machine must be level.
- Vent the ice machine and bin drains separately.
- Bin drain termination must have an air gap.
- The ice machine and bin must be de-scaled and sanitized after installation.
- The drain line must contain a union or other suitable means of disconnection at the ice machine.
- The water inlet and electrical connection must contain a service loop to allow future access.
- The location must not allow exhaust fan heat and/or grease to enter the condenser.

## Minimum Cut-Out For Built-In Installations

The ice machine may be built into a cabinet. If built into a cabinet, ice machine must be removable for de-scaling and sanitizing procedures.

Cut-Out Dimensions	K150/K250
Width	31.0" (79 cm)
Depth	33.5" (85 cm)
Height	43.5" (111 cm)

## Heat of Rejection

Series	Ice Machine Heat of Rejection*	
	Air Conditioning**	Peak
KP150	2400	2900
KP250	2800	3300

\* B.T.U./Hour

\*\* Because the heat of rejection varies during the ice making cycle, the figure shown is an average.

Ice machines, like other refrigeration equipment, reject heat through the condenser. It is helpful to know the amount of heat rejected by the ice machine when sizing air conditioning equipment where self-contained air-cooled ice machines are installed.

### LEVELING THE ICE MACHINE

1. Screw the leveling legs onto the bottom of the ice machine.
2. Screw the foot of each leg in as far as possible.
3. Move the ice machine into its final position.
4. Level the ice machine by using a level on top of the ice machine. Turn each foot as necessary to level the ice machine from front to back and side to side.

## Electrical Service

### ELECTRICAL REQUIREMENTS

All electrical work, including wire routing and grounding, must conform to local, state and national electrical codes. The following precautions must be observed:

- The ice machine must be grounded.
- A separate fuse/circuit breaker (dedicated circuit) must be provided for each ice machine.
- A qualified electrician must determine proper wire size dependent upon location, materials used and length of run (minimum circuit ampacity can be used to help select the wire size).

#### **⚠ Warning**

All wiring must conform to local, state and national codes.

### VOLTAGE

The maximum allowable voltage variation is  $\pm 10\%$  of the rated voltage on the ice machine model/serial number plate at start-up (when the electrical load is highest).

The 115/1/60 ice machines are factory pre-wired with an 8' power cord and NEMA 5-15P-plug configuration.

The 208-230/1/60 and 230/50/1 ice machines are factory pre-wired with an 8' power cord only, no plug is supplied.

### FUSE/CIRCUIT BREAKER

A separate electrical disconnect, which disconnects all poles and has 1/8" (3 mm) contact separation, must be provided for fixed wiring. Circuit breakers must be H.A.C.R. rated in USA.

**TOTAL CIRCUIT AMPACITY**

The total circuit ampacity is used to help select the wire size of the electrical supply.

The wire size (or gauge) is also dependent upon location, materials used, length of run, etc., so it must be determined by a qualified electrician.

**GROUND FAULT CIRCUIT INTERRUPTER**

We do not recommend the use of a GFCI/GFI circuit protection with our equipment. If a GFCI/GFI is required by code, use a GFCI/GFI breaker rather than an outlet, which is more prone to intermittent nuisance trips than panel circuit breakers.

**MAXIMUM BREAKER SIZE & TOTAL AMPERAGE CHART**

NOTE: Due to continuous product improvements, this information is for reference only. Please refer to the ice machine data plate to verify electrical data. Model/Serial tag information overrides information listed on this page.

Ice Machine	Voltage Phase Cycle	Air-Cooled		Water-Cooled	
		Maximum Fuse/ Circuit Breaker	Total Amps	Maximum Fuse/ Circuit Breaker	Total Amps
<b>KP150</b>	115/1/60	15	5.0	–	–
<b>KP250</b>	115/1/60	15	7.0	15	6.0

## Water Supply and Drain Line Requirements

### WATER CONNECTIONS

- Local water conditions may require treatment of the water to inhibit scale formation, filter sediment, and remove chlorine odor and taste.
- All water and drains must conform to all applicable codes of the authority having jurisdiction. It is the responsibility of the end user to satisfy all local codes.
- Connect ice making water inlet to potable water only.
- Install a water shut-off valve for potable water and water cooled condenser lines.
- Do not connect the ice machine to a hot water supply. Verify hot water restrictors installed on other equipment are functioning correctly. (Check valves on sink, faucets, dishwashers, etc.)
- Install a water regulating valve if water pressure exceeds the maximum valve rating.
- Insulate water and drain lines to prevent condensation.

### DRAIN CONNECTIONS

Follow these guidelines when installing drain lines to prevent drain water from flowing back into the ice machine and storage bin:

- Drain lines must have a 1.5 inch drop per 5 feet (2.5 cm per meter) of run and must not create traps.
- The floor drain must be large enough to accommodate drainage from all drains.
- Run separate bin and ice machine drain lines. Insulate them to prevent condensation.
- Install a tee at the ice making water drain outlet and install an 8.0" (20 cm) vent above the ice making water drain line.
- Drain termination must have an air gap that meets local code.

### WATER SUPPLY

Local water conditions may require treatment of the water to inhibit scale formation, filter sediment, remove chlorine, and improve taste and clarity.

### WATER INLET LINES

Follow these guidelines to install water inlet lines:

- Do not connect the ice machine to a hot water supply. Be sure all hot water restrictors installed for other equipment are working. (Check valves on sink faucets, dishwashers, etc.)
- If water pressure exceeds the maximum (80 psig- 551.5 kPa) recommended pressure, obtain a water pressure regulator from your Manitowoc distributor.
- Install a water shut-off valve and union for both the ice-making and condenser water lines.
- Insulate water inlet lines to prevent condensation..

### COOLING TOWER APPLICATIONS

(Water-Cooled Models)

A water cooling tower installation does not require modification of the ice machine. The water regulator valve for the condenser continues to control the refrigeration discharge pressure.

It is necessary to know the amount of heat rejection and the pressure drop through the condenser and water valves (inlet and outlet) when using a cooling tower on an ice machine.

- Water entering the condenser must not exceed 90°F (32°C).
- Water flow through the condenser must not exceed 5 gallons (19 liters) per minute.
- Allow for a pressure drop of 7 psi (48 kPa) between the condenser water inlet and the outlet of the ice machine.
- Water exiting the condenser must not exceed 110°F (43°C).

**WATER SUPPLY & DRAIN LINE SIZING CONNECTIONS**

Location	Water Temperature	Water Pressure	Ice Machine Fitting	Tubing Size Up To The Ice Machine Fitting
A=Ice Making Water Inlet	40°F (4°C) Min. 90°F (32°C) Max.	20 psi (137.9 kPa) Min. 80 psi (551.5 kPa) Max.	3/8 Female Pipe Thread	3/8 (9.5 mm) minimum inside diameter
B=Ice Making Water Outlet	---	---	1/2 Female Pipe Thread	1/2 (12.7 mm) minimum inside diameter
C=Bin Drain	---	---	1/2 Female Pipe Thread	1/2 (12.7 mm) minimum inside diameter
D=Condenser Water Inlet	40°F (4°C) Min. 90°F (32°C) Max.	20 psi (137.9 kPa) Min. 150 psi (1034.2 kPa) Max	3/8 Female Pipe Thread	3/8 (9.5 mm) minimum inside diameter
E=Condenser Water Drain	---	---	1/2 Female Pipe Thread	1/2 (12.7 mm) minimum inside diameter

Min.=Minimum, Max.=Maximum

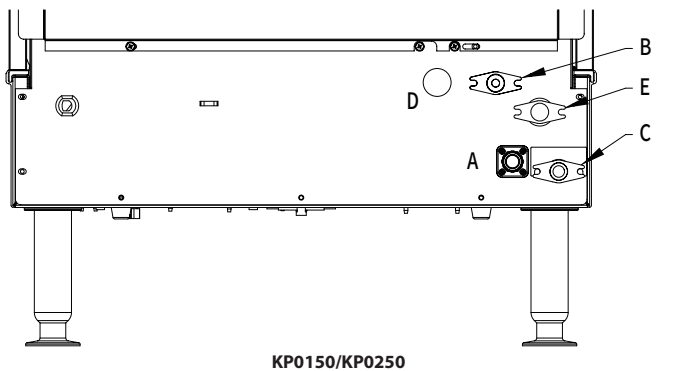

KP0150/KP0250

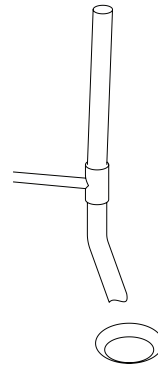

Floor Drain - Open and Vent 8" (20cm)  
Above B = Ice Making Water Drain Outlet

**Water Supply & Drain Locations**

**⚠ Caution**

Do not apply heat to water inlet valve or water drain fittings. Heating will damage the nonmetallic connector. Do not over tighten fittings. Two turns after hand tight is the maximum.

**INSTALLATION NOTE(SWITZERLAND)**

The connection to the drinking water network must be made with a certified backflow preventer type EA (EN13959) and with a certified connection hose (EN13618 or EN61770) on site.

### Ice Thickness Adjustment

The ice thickness can be adjusted to three levels.

1. Pull forward on the bottom of the bracket until clear of the tab.
2. Slide the bracket over the desired tab and release.
  - The center position is the normal factory setting.
  - To increase bridge thickness, raise the water level.
  - To decrease bridge thickness, lower the water level.

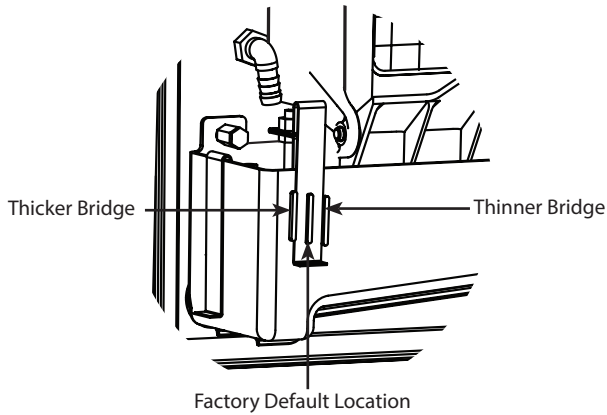

Model	Total ice weight from one cycle	
	Minimum - Maximum	Minimum - Maximum
KP150	1.13 - 1.36 lbs	513 - 617 grams
KP250	2.26 - 2.93 lbs	1025 - 1329 grams

### Refrigerant Charge

Model	Amount	Type
KP150	4.9 OZ 140 g	R290
KP250	5.3 OZ 150 g	

\*Model/serial tag information overrides all data listed in this chart.

### Starting the Ice Machine

Starting the ice machine and completing the Operational Checks are the responsibilities of the owner/operator.

Adjustments and maintenance procedures outlined in this manual are not covered by the warranty.

The ice machine and bin must be sanitized prior to operation.

#### INSTALLATION CHECKLIST

√	Checklist Item
	Has the ice machine been installed where ambient temperatures will remain in the range of 40° – 100°F (4° – 38°C)?
	Has the ice machine been installed where the incoming water temperature will remain in the range of 40° – 90°F (4° – 32°C)?
	Has all of the internal packing been removed?
	Is there proper clearance around the ice machine for air circulation?
	Is the ice machine level?
	Are all electrical leads free from contact with refrigeration lines and moving equipment?
	Has the supply voltage been tested and checked against the rating on the nameplate?
	Are all electrical and water connections complete?
	Is the ice machine grounded and polarity correct?
	Is there a separate drain for the water-cooled condenser?
	Is there a separate vented drain for the bin?
	Has the On/Off button been pressed?
	Has the owner/operator completed the warranty registration card?
	Has the owner/operator been instructed regarding maintenance and the use of Manitowoc De-scaler and Sanitizer?
	Has the ice machine and bin been sanitized?

## Section 3 Operation

### Touch Pad Features

The touch pad offers a series of pressure sensitive buttons to control ice machine operation and provide operational status.



On/Off - Blue = Machine Is On  
Off = Machine Is Off

Delay - Blue = Delay Mode Is On  
Off = Delay Mode Is Off

Clean - Yellow = Clean Cycle Is On  
Off = Cleaning Is Off  
Flashing = Cleaning Is Paused

Bin Full - Blue = Bin Is Full  
Off = Bin Is Not Full

Service - Red = Service Limit  
Off = Doesn't Need Service

NOTE: Touch pad is to be activated with finger tips only. Do not disassemble touch pad.

### ON/OFF BUTTON

The On/Off button is used to start and stop ice making.

- Pressing the On/Off button for 3 seconds will power off the unit.

The blue light indicates whether the ice machine is Ice Making (light on) or Off (light off).

NOTE: If ice is on the evaporator (during the freeze or harvest cycle) and the On/Off button is pressed, the next cycle will have a thick slab of ice. Press the On/Off button and allow the ice to melt off the evaporator, then start a new freeze cycle.

### DELAY BUTTON

Pressing the Delay button will start a delay period. The ice machine will finish the freeze and harvest cycle and then start the delay period.

- Pressing the button once will start a 4 hour delay period.
- Pressing the button twice will start a 12 hour delay period.
- Pressing the button three times will start a 24 hour delay period.
- Pressing the button four times will cancel the delay periods.

NOTE: The delay period will be canceled if power is interrupted to the ice machine. When power is restored, the ice machine will remain Off.

### CLEAN BUTTON

Pressing the Clean button for 3 seconds with the machine off will start a clean cycle. After the clean cycle is complete, the ice machine will automatically start an ice making cycle.

- Pressing the Clean button again within 45 seconds of the clean cycle starting will abort the clean cycle.
- Pressing the On/Off button anytime during the clean cycle will de-energize the On/Off LED and the ice machine will stop after the clean cycle is complete.
- Pressing the Clean button will pause the clean cycle. The On/Off and Clean lights will flash on/off to indicate pause mode. Pressing the Clean button again will continue the clean cycle from the point of interruption.

NOTE: Opening the ice damper for 30 seconds will cancel the clean cycle.

### BIN FULLICON

The Bin Full light energizes when the bin is full or is de-energized if the bin is not full.

### SERVICE ICON

The Service light indicates the machine needs attention.

Refer to Section 5 for more information if this light is energized.

## Ice Making Sequence of Operation

NOTE: The On/Off button must be powered On - light blue and the ice damper must be closed before the ice machine will start.

### Water Purge Cycle

The ice machine purges any remaining water from the water trough down the drain.

### Freeze Cycle

Prechill - The refrigeration system chills the evaporator before water flow over the evaporator starts. The water inlet valve energizes during the pre-chill and remains on until the ice thickness float switch is satisfied.

Freeze - With water trough thermistor, the following sequence occurs in the freeze cycle:

- When the water temperature reaches 34°F, the water pump will de-energize for 25 seconds, then re-energizes.
- When the water pump restarts the water inlet solenoid energizes for 7 seconds.
- Water flowing across the evaporator will start to freeze and build ice on the evaporator. After a sheet of ice has formed, the harvest float switch signals the control board to start a harvest cycle.

### Harvest Cycle

Every fourth cycle, any remaining water is purged down the drain as refrigerant gas warms the evaporator. When the evaporator warms, the sheet of cubes slides off the evaporator and into the storage bin. If all cubes fall clear of the ice damper, the ice machine starts another freeze cycle.

### Full Bin Cycle

If the ice damper is held open by ice cubes, the ice machine shuts off. When the ice damper closes, the ice machine starts a new cycle at the water purge.

### Optional Cycle Bypass - Water Purge

To bypass this feature and purge every harvest cycle:

1. Press & hold the Clean button for **3 seconds while in the ice making cycle.**
2. Press the Delay button.
3. The Service light will flash red, 5 times to indicate bypass. The machine will purge water every cycle.
4. Repeat steps to reinstate fourth cycle -water purge.
5. The Service light will flash red, 6 times to indicate fourth cycle - water purge.

NOTE: Bypassing the Water Purge will increase water usage.

## Control Board Timers

The control board has the following non-adjustable timers:

- The ice machine is locked into the freeze cycle for 6 minutes before a harvest cycle can be initiated.
- The maximum freeze time is 45 minutes, at which time the control board automatically initiates a harvest sequence.
- The maximum harvest time is 7 minutes. When harvest is complete the control board automatically initiates a freeze sequence.
- If the ice damper does not open and close within the 7 minute harvest cycle, the ice machine enters a water thaw cycle for 170 seconds. If the damper does not open and close within the 170 second thaw cycle, a second thaw cycle starts. The control board automatically initiates a freeze sequence when the thaw cycle(s) is complete.

## SERVICE LIMITS

Service limits are stored and indicated by the control board. The number of cycles required to stop the ice machine varies for each service limit.

Service limits can be reset by pressing the On/Off button and starting a new ice making cycle.

A service limit is indicated by an energized Service Light on the touch pad. Refer to Section 5 if you receive a service limit indication.

- Service Limit 1 - If the freeze time reaches 45 minutes, the control board automatically initiates a harvest cycle. After 6 consecutive 45-minute freeze cycles occur, the ice machine stops.
- Service Limit 2 - If the harvest time reaches 3.5 minutes, the control board automatically energizes the water pump and extends the harvest cycle another 3.5 minutes (7 minutes total). If the ice damper does not open and close within the 7 minute harvest cycle, the ice machine enters a water thaw cycle for 170 seconds. If the damper does not open and close within the 170 second thaw cycle, a second thaw cycle starts. The control board automatically initiates a freeze sequence when the thaw cycle(s) is complete. If 3 consecutive 7 minute harvest and thaw cycles occur, the ice machine stops.
- Service Limit 3 - If the freeze time reaches 4 minutes and water is not sensed, the ice machine stops and initiates a 30 minute delay period. The ice machine will automatically restart at the end of the 30 minute delay period. If 100 consecutive failures occur, the ice machine stops.

# Section 4 Maintenance

## De-scaling and Sanitizing

### GENERAL

De-scale and sanitize the ice machine every six months for efficient operation. If the ice machine requires more frequent de-scaling, consult a qualified service company to test the water quality and recommend appropriate water treatment. An Extremely dirty ice machine must be taken apart for de-scaling and sanitizing.

Sanitizing for Exterior, Remedial, and Detailed procedures can be performed independently and more frequently than de-scaling when needed.

### Caution

Use only Koolaire approved Ice Machine De-scaler and Sanitizer. Using a non Manitowoc de-scaler or sanitizer may result in bodily harm and/or cause damage to the ice machine that is not covered under the warranty. Do not use de-scaler or sanitizer quantities that exceed the amounts listed in this manual. Do not use these solutions in a manner inconsistent with their labeling. Read and understand all labels printed on bottles before use.

### DETAILED DE-SCALING/SANITIZING PROCEDURE

This procedure must be performed a minimum of once every six months.

- The ice machine and bin must be disassembled de-scaled and sanitized.
- All ice produced during the de-scaling and sanitizing procedures must be discarded.

### REMEDIAL DE-SCALING PROCEDURE

- This procedure de-scales all components in the water flow path, and is used between the bi-yearly detailed de-scaling and sanitizing procedure.

## Detailed De-scaling and Sanitizing Procedure

Ice machine de-scaler is used to remove lime scale and mineral deposits.

Ice machine sanitizer disinfects and removes algae and slime.

### Touch Pad Operation

Pressing and holding the Clean button for 3 seconds starts the clean cycle. The Clean and On/Off lights energize indicating the clean cycle has started and ice making will automatically start when the clean cycle is complete.

- Setting the ice machine to stop after the clean cycle: Press the On/Off button. The On/Off light will de-energize, indicating the ice machine will stop after the clean cycle.
- Pausing the clean cycle: Press the Clean button. The clean light will flash indicating the clean cycle has paused. Pressing the Clean button again will restart the clean cycle.

**NOTE: If the ice damper is open for 2 seconds, the clean cycle will pause. If the damper is open for 30 seconds, the clean cycle will be canceled.**

### DE-SCALING PROCEDURE

**Step 1** Open the bin door to access the evaporator compartment. Ice must not be on the evaporator during the de-scaling/sanitize cycle. Follow one of the methods below:

- Press the On/Off button for 3 seconds at the end of a harvest cycle after ice falls from the evaporator.
- Press the On/Off button for 3 seconds and allow the ice to melt.

**Step 2** Remove all ice from the bin.

**Step 3** To start a clean cycle, press the Clean button. Water will flow through the water dump valve and down the drain. Wait until the water trough refills, then add the proper amount of ice machine de-scaler to the water trough.

Model	Amount of De-scaler
KP150	2 ounces (60 ml)
KP250	5 ounces (150 ml)

### Caution

Do not mix De-scaler and Sanitizer solutions together. It is a violation of Federal law to use these solutions in a manner inconsistent with their labeling.

**⚠ Warning**

Wear rubber gloves and safety goggles (and/or face shield) when handling Ice Machine De-scaler or Sanitizer.

**Step 4** Wait until the clean cycle is complete (approximately 22 minutes) then press the On/Off button and disconnect power and water supplies to the ice machine.

**⚠ Warning**

Disconnect the electric power to the ice machine at the electric service switch box.

**Step 5** Remove parts for de-scaling.

Refer to the “Remove Parts for De-scaling or Sanitizing” on page 23. Continue with step 6 when the parts have been removed.

**Step 6** Mix a solution of de-scaler and warm water. Depending on the amount of mineral buildup, a larger quantity of solution may be required. Use the ratio in the table below to mix enough solution to thoroughly clean all parts.

Solution Type	Water	Mixed with
De-scaler	1 gal. (4 l)	16 oz (500 ml) de-scaler

**⚠ Caution**

Do not immerse electrical connectors or motors for any components in water, de-scaler, or sanitizer solutions.

**Step 7** Use half of the de-scaler and water solution to clean all components. The de-scaler solution will foam when it contacts lime scale and mineral deposits; once the foaming stops, use a soft bristle brush, sponge, or cloth (not a wire brush) to carefully clean the parts. Soak the parts for 5 minutes (15 – 20 minutes for heavily scaled parts). Rinse all components with clean water.

**Step 8** While components are soaking, use half of the de-scaler and water solution to clean all foodzone surfaces of the ice machine and bin. Use a nylon brush or cloth to thoroughly clean the following ice machine areas:

- Evaporator plastic parts – including top, bottom, and sides
- Bin bottom, sides, and top

Rinse all areas thoroughly with clean water.

**SANITIZING PROCEDURE**

**NOTE: Sanitizing can be performed independently and more frequently than de-scaling when needed.**

**Step 9** Mix a solution of sanitizer and warm water.

Solution Type	Water	Mixed With
Sanitizer	3 gal. (12 l)	2 oz (60 ml) sanitizer

**Step 10** Use half of the sanitizer and water solution to sanitize all removed components(Refer to “Remove Parts for De-scaling or Sanitizing” on page 23). Use a spray bottle to liberally apply the solution to all surfaces of the removed parts or soak the removed parts in the sanitizer and water solution. **Do not rinse parts after sanitizing.**

**Step 11** Use half of the sanitizer and water solution to sanitize all foodzone surfaces of the ice machine and bin. Use a spray bottle to liberally apply the solution. When sanitizing, pay particular attention to the following areas:

- Evaporator plastic parts - including top, bottom, and sides
- Bin bottom, sides, and top

**Do not rinse the sanitized areas.**

**Step 12** Apply food grade lubricant to all o-rings, then replace all removed components. Wait 10 minutes and then reapply power and water to the ice machine

**Step 13** Press the Clean button. Water will flow through the water dump valve and down the drain. Wait until the water trough refills, then add the proper amount of ice machine sanitizer to the water trough.

Model	Amount of Sanitizer
KP150	1 ounce (30 ml)
KP250	2 ounces (60 ml)

**Step 14** Close and secure all panels and bin door. The ice machine will automatically start ice making after the sanitize cycle is complete (approximately 22 minutes).

**REMOVE PARTS FOR DE-SCALING OR SANITIZING**

**Notice**

Electrical connectors must never be exposed to any liquids.

A. Remove the ice thickness and harvest float switch.

Pull forward on the bottom of the bracket until clear of the tab, then slide bracket upward to remove the bracket and float switch as an assembly.

**NOTE: At this point, the component can easily be cleaned. If complete removal is desired, follow the wires to the bulkhead grommet (exit point) in the back wall. Pull the wire connector through the bulkhead grommet, then disconnect the wire leads from the connector.**

**Important**

Reversing the mounting location of the ice thickness and the harvest floats will result in a safety limit 2 failure.

- The ice thickness float must be mounted to the front of the water trough and the electrical connection must be in the top bulkhead grommet.
- The harvest float must be mounted to the side of the water trough and the electrical connection must be in the bottom bulkhead grommet.
- The wire connectors for each float are different and will not allow incorrect electrical bulkhead connection.

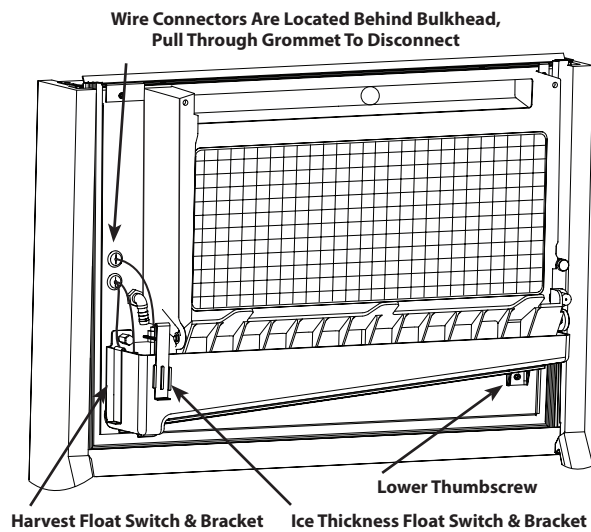

**Caution**

Do not disassemble the float switches for de-scaling and/or sanitizing - incorrect reassembly will result in an ice machine that will not harvest.

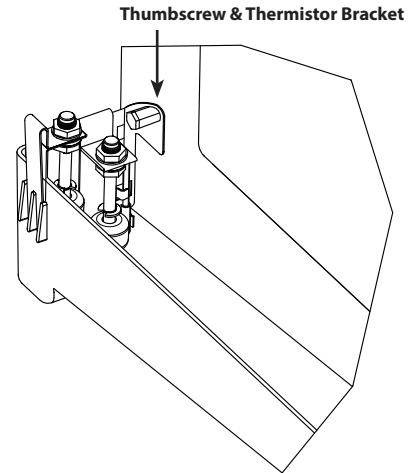

B. Remove water trough thermistor and water trough.

- While supporting the water trough, remove the upper thumbscrew and lift off the thermistor.
- Continue supporting the water trough and remove the thumbscrew from beneath the water trough.
- Remove the water trough from the bin area.

**NOTE: At this point, the thermistor can easily be cleaned. If complete removal is desired, follow the wires to the bulkhead grommet (exit point) in the back wall. Pull the wire connector through the bulkhead grommet, then disconnect the wire leads from the connector.**

C. Remove the ice damper and water distribution tube.

- Remove thumbscrew from bin switch cover.
- Support ice damper and then pull bin switch cover and ice damper forward to remove.
- Remove thumbscrews from the water distribution tube, then remove.

Remove Thumbscrews From Distribution Tube and Remove

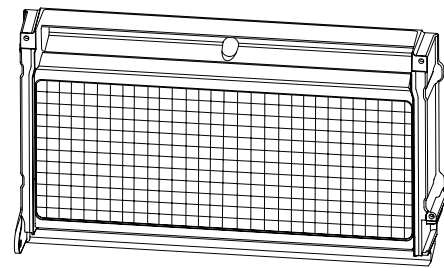

Remove Thumbscrew From Bin Switch Cover, Support The Damper, and Remove

## Remedial De-scaling

This procedure de-scales all components in the water flow path, and is used to de-scale the ice machine between the bi-yearly detailed de-scaling and sanitizing procedure.

Ice machine de-scaler is used to remove lime scale and mineral deposits.

**Step 1** Press the On/Off button after ice falls from the evaporator at the end of a Harvest cycle. Or, press the On/Off button and allow the ice to melt off the evaporator.

 **Caution**

Never use anything to force ice from the evaporator. Damage may result.

**Step 2** To start a clean cycle, press the Clean button. Water will flow through the water dump valve and down the drain. Wait until the water trough refills, then add the proper amount of ice machine de-scaler to the water trough.

Model	Amount of De-scaler
KP150	2 ounce (60 ml)
KP250	5 ounces (150 ml)

**Step 3** Wait until the clean cycle is complete (approximately 22 minutes) then press the On/Off button.

## Ice Machine Inspection

Check all water fittings and lines for leaks. Also, make sure the refrigeration tubing is not rubbing or vibrating against other tubing, panels, etc.

Do not put anything (boxes, etc.) in front of the ice machine. There must be adequate airflow through and around the ice machine to maximize ice production and ensure long component life.

## Exterior Cleaning

Clean the area around the ice machine as often as necessary to maintain cleanliness and efficient operation.

Wipe surfaces with a damp cloth rinsed in water to remove dust and dirt from the outside of the ice machine. If a greasy residue persists, use a damp cloth rinsed in a mild dish soap and water solution. Wipe dry with a clean, soft cloth.

Clean up any fallen ice or water spills as they occur.

## LuminIce® Bulb Maintenance

It is recommended to check the LuminIce bulb during De-scaling & Sanitizing Procedure.

LuminIce bulbs require replacement on a yearly basis. The bulb will still illuminate after 12 months, the effectiveness of the bulb diminishes as operational hours increase. To retain maximum effectiveness, replace the bulb on a 12 month schedule.

### BULB REPLACEMENT

LuminIce II has an indicator light on the device that will illuminate blue when operating normal or red when the bulb needs replacement.

- Replace with a LuminIce II bulb with white bulb base: K00528.

### CLEAN-UP PROCEDURE

#### Accidental Bulb Breakage

The clean up procedure is identical to the procedure used to clean up compact fluorescent (CFL) or fluorescent tube lights. These lights contain a small amount of mercury sealed within a glass tube. Breaking these types of lights will release mercury and mercury vapor. The broken bulb can continue to release mercury vapor until it is cleaned up and removed.

The latest EPA procedures can be viewed on their website at: [www.epa.gov/cfl/cflcleanup.html](http://www.epa.gov/cfl/cflcleanup.html).

## Cleaning the Air Condenser Filter

The washable aluminum filter on self-contained ice machines is designed to catch dust, dirt, lint and grease. Clean the filter with a mild soap and water.

Air filter must be inspected monthly and cleaned bi-monthly.

## Cleaning the Air Condenser

A dirty condenser restricts airflow, resulting in excessively high operating temperatures. This reduces ice production and shortens component life.

- Clean the condenser at least every six months.
- Shine a flashlight through the condenser to check for dirt between the fins.
- Blow compressed air from the inside out (opposite direction of airflow).
- If dirt still remains, call a service agent to clean the condenser.

## Bin Removal

**NOTE:** Although not required and dependent on your installation, removing the bin may allow easier access.

- Disconnect power and remove all ice from bin.
- Remove air filter and louvered front panel/grill from lower front of machine.
- Loosen screws and rotate clips to release bin from base.
- Disconnect bin drain line clamp and remove bin drain line.
- Disconnect touch pad communication cable from the control board harness .
- Slide bin forward to remove.

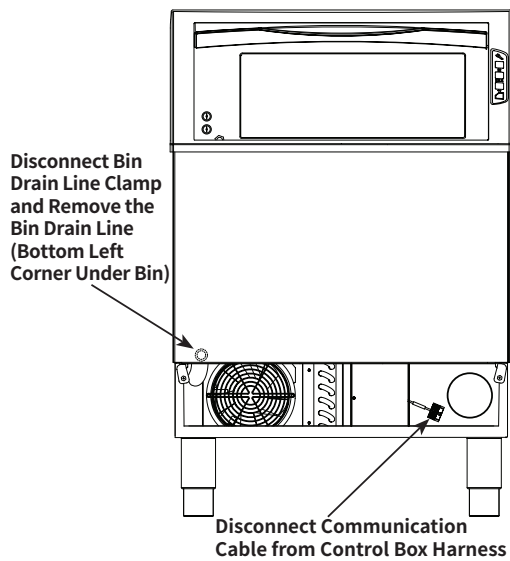

### Caution

When reinstalling the bin, the bin seal gasket must seal tightly to the cabinet. Confirm the bin seal gasket is not pinched or folded. A water tight seal is required to prevent future condensation and/or water leakage from entering the ice machine base and damaging the unit.

## Removal from Service/Winterization

### GENERAL

Special precautions must be taken if the ice machine is to be removed from service for an extended period of time or exposed to ambient temperatures of 32°F (0°C) or below.

### Notice

If water is allowed to remain in the ice machine in freezing temperatures, severe damage to some components could result. Damage of this nature is not covered by the warranty.

**Step 1** De-scaled and sanitize the ice machine.

**Step 2** Press the On/Off button for 3 seconds to turn off the ice machine.

**Step 3** Turn off the water supply, disconnect and drain the incoming ice-making water line at the rear of the ice machine, and drain the water trough.

**Step 4** Energize the ice machine, wait one minute for the water inlet valve to open, and blow compressed air in both the incoming water and the drain openings in the rear of the ice machine to remove all water.

**Step 5** Press the On/Off button for 3 seconds and disconnect the electric power at the circuit breaker or the electric service switch.

**Step 6** Fill spray bottle with sanitizer and spray all interior food zone surfaces. Do not rinse and allow to air dry.

**Step 7** Replace all panels.

THIS PAGE INTENTIONALLY LEFT BLANK

## Section 5 Troubleshooting

### Checklist

If a problem arises during operation of your ice machine, follow the checklist below before calling service. Routine adjustments and maintenance procedures are not covered by the warranty.

Problem	Possible Cause	To Correct
Ice machine does not operate.	No electrical power to the ice machine.	Replace the fuse/reset the breaker/turn on the main switch/plug power cord into receptacle.
	Ice machine needs to be turned on.	Press the On/Off button to start ice making.
	Damper in open position (down).	Damper must be in upright position and capable of swinging freely.
Ice machine stops, and can be restarted by turning the ice machine OFF and then ON.	Service limit feature stopping the ice machine.	Refer to "Service Limit Feature" on the next page.
Ice sheet is thick.	Water trough level is too high.	Adjust ice thickness float.
	Power button was turned off/on during freeze cycle and ice remained on evaporator.	Allow ice to thaw and release from evaporator, then restart.
	Ice damper was opened then closed in the harvest cycle before the ice released.	Allow ice to thaw and release from evaporator, then restart.
	Long harvest cycles with repeated service limit indication.	Call for service.
Ice machine does not release ice or is slow to harvest.	Ice machine is dirty.	De-scale and sanitize the ice machine.
	Ice machine is not level.	Level the ice machine.
	Low air temperature around ice machine (air-cooled models).	Air temperature must be at least 40°F (4°C).
	Water regulating valve leaks in harvest mode (water-cooled models).	Replace water regulating valve.
Ice machine does not cycle into harvest mode.	The six-minute freeze time lock-in has not expired yet.	Wait for freeze lock-in to expire.
	Harvest float switch is dirty.	De-scaler and sanitize the ice machine.
	Harvest float switch wire is disconnected.	Connect the wire.
	Harvest float switch is out of adjustment.	Adjust the harvest float switch.
	Uneven ice fill (thin at top of evaporator).	See "Shallow or Incomplete Cubes" below.
Ice quality is poor (soft or not clear).	Poor incoming water quality.	Contact a qualified service company to test the quality of the incoming water and make appropriate filter recommendations.
	Water filtration is poor.	Replace the filter.
	Ice machine is dirty.	De-scaler and sanitize the ice machine.
	Water softener is working improperly (if applicable).	Repair the water softener.
Ice machine produces shallow or incomplete cubes, or the ice fill pattern on the evaporator is incomplete.	Ice thickness switch is out of adjustment.	Adjust the ice thickness switch.
	Water trough level is too high or too low.	Check the water level.
	Water filtration is poor.	Replace the filter.
	Hot incoming water.	Connect the ice machine to a cold water supply.
	Incorrect incoming water pressure.	Water pressure must be 20 – 80 psi (137.9 – 551.5 kPa)
	Ice machine is not level.	Level the ice machine.

Problem	Possible Cause	To Correct
Low ice capacity.	The condenser is dirty.	Clean the condenser.
	High air temperature around ice machine (air-cooled models).	Air temperature must not exceed 100°F (38°C).
	Inadequate clearance around the ice machine.	Provide adequate clearance.
	Objects stacked around ice machine, blocking airflow to condenser (air-cooled models)	Remove items blocking airflow.
	Hot incoming water.	Connect the ice machine to a cold water supply.
	Incorrect incoming water pressure. Water pressure is too low or water filter is restricted.	Water pressure must be 20 – 80 psi (137.9 – 551.5 kPa). Refer to section 2 for plumbing requirements. Replace water filter.

### Service Limit Feature

In addition to the standard service controls, such as the high pressure cutout, your Koolaire ice machine features built-in service limits, which will stop the ice machine if conditions arise which could cause a major component failure.

Before calling for service, re-start the ice machine using the following procedure:

1. Press the On/Off button and turn off the ice machine, then press the On/Off button again to start the ice machine.
  - A. If the service limit feature has stopped the ice machine, it will restart after a short delay. Proceed to step 2.
  - B. If the ice machine does not restart, see "Ice machine does not operate" on the previous page.
2. Allow the ice machine to run to determine if the condition is recurring.
  - A. If the ice machine stops again, the condition has recurred. Call for service.
  - B. If the ice machine continues to run, the condition has corrected itself. Allow the ice machine to continue running.



# **KOOLAIRE**

▶ FROM MANITOWOC

MANITOWOC ICE  
2110 SOUTH 26TH STREET, MANITOWOC, WI 54220

800-545-5720  
[WWW.MANITOWOCICE.COM](http://WWW.MANITOWOCICE.COM)