



Koolaire KP0500
Ice Cube Machine on K-570 Bin

KP0500

Koolaire Ice Cube Machine

KDP0500A | KYP0500A | KDP0500W | KYP0500W

ICE SHAPES



▶ **Half-Dice:** 3/8" x 1 1/8" x 7/8"
(0.95 x 2.86 x 2.22 cm)



▶ **Dice:** 7/8" x 7/8" x 7/8"
(2.22 x 2.22 x 2.22 cm)

SIZE

- ▶ Up to 522 lbs (237 kgs) of daily ice production
- ▶ 30" (76.20 cm) wide, 34" (72.4 cm) deep, and 71.5 (181.61 cm) high on 6" (15.24 cm) legs
- ▶ 532 lb (241 kgs) ice bin storage capacity*

*Application capacity based on 90% volume x 33 lbs./ft³ average density of ice

SPECIFICATIONS

Refrigerant: R290

- ▶ Air-cooled: 5.3 oz (150 g)
- ▶ Water-cooled: 6.4 oz (180 g)

BTU Per Hour

- ▶ 7,515 (average)
- ▶ 8,905 (peak)

Operating Limits

- ▶ Ambient temperature range: 40° to 110°F (4.4° to 43.3°C)
- ▶ Water temperature range: 40° to 90°F (4.4° to 32.2°C)
- ▶ Water pressure ice maker (water in)
 - Min. 20 psi (137.9 kPa)
 - Max. 80 psi (551.1 kPa)
- ▶ Condenser inlet water in (water-cooled only)
 - Min. 20 psi (137.9 kPa)
 - Max. 275 psi (1,896.06 kPa)

Power

- ▶ 115/60/1 standard
- ▶ Minimum circuit ampacity:
 - Air-cooled: 12.5
 - Water-cooled: 11.8
- ▶ Maximum Fuse Size
 - Air-cooled: 20 Amps
 - Water-cooled: 20 Amps

FEATURES / BENEFITS

- ▶ AHRI performance certified
- ▶ Energy-efficient models (see EnergyStar.gov)
- ▶ Durable nickel-plated copper evaporators (Made in Manitowoc, WI)
- ▶ Simple 3-position control: ON / OFF / CLEAN
- ▶ Smudge-resistant stainless-like exterior
- ▶ R290 offers a 99.86% GWP reduction compared to R410A
- ▶ Front-facing evaporator for easy access
- ▶ One-touch cleaning—just add chemical, no ice removal needed
- ▶ Tool-free removal of food zone components
- ▶ Smooth, white plastic interior for quick wipe-downs
- ▶ Sealed food zone with commercial-grade gaskets
- ▶ Alpha San antimicrobial protection in key parts

ACCESSORIES

- ▶ LuminIce® II Virus and Bacteria Inhibitor Controls viruses and bacteria in the ice machine.
- ▶ Dispenser Bin Thermostat Kit Reduces condensation when used with dispensers.
- ▶ Arctic Pure Pro water filters reduce chlorine, taste, odor and filter sediment down to 5 microns



LuminIce II



Thermostat Kit



Arctic Pure Water Filters

KP0500

Koolaire Ice Cube Machine

KDP0500A | KYP0500A | KDP0500W | KYP0500W

INSTALLATION

Ice machine must be installed indoors.

Recommended clearance for

- top and sides is 8" (20.3 cm)

- back is 5" (12.7 cm)

- A** Electrical Entrance (2) Options
- B** 3/8" (0.95 cm) F.P.T. Ice Making Water Inlet
- C** 1/2" (1.27 cm) F.P.T. Ice Making Water Outlet
- D** 1/2" (1.27 cm) Condenser Water Outlet (water cooled models only)
- E** 3/8" (0.95 cm) F.P.T. Condenser Water Inlet (water cooled models only)
- F** 3/4" (1.91 cm) Bin Drain

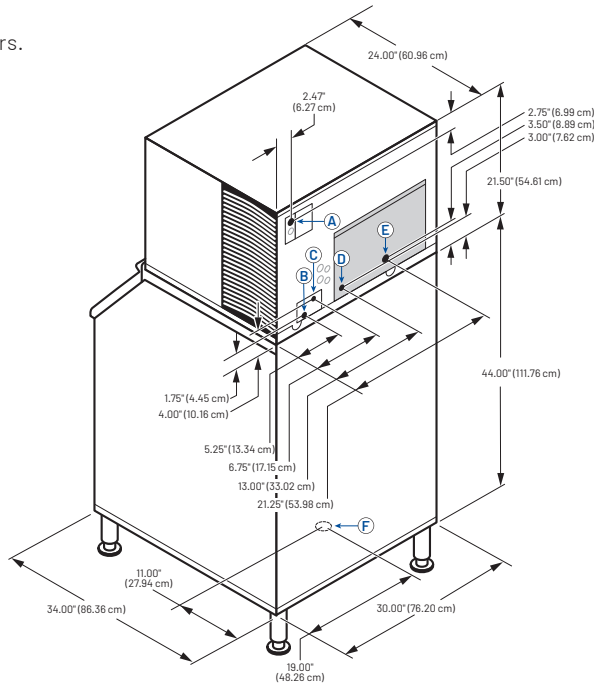

SPACE-SAVING DESIGN



	KP0500 K-400	KP0500 K-570
Height	59.50" / 151.13 cm	71.5" / 181.61 cm
Width	30.0" / 76.2 cm	30.0" / 76.2 cm
Depth	34.0" / 86.36 cm	34.0" / 86.36 cm
Bin Storage	365 lbs / 165 kgs	532 lbs / 241 kgs

Height includes adjustable bin legs 6.00" to 8.00", (15.24 to 20.32 cm) set at 6.00" (15.24 cm).

Bin capacity is based on 90% of the volume x 33 lbs/ft³ average density of ice. Ice machine and bin sold separately.

SPECIFICATIONS

	Model	Ice Shape	Shipping Weight	Ice Production 24 Hours		Power Usage kWh per 100 lbs of ice	Ice Machine Potable water usage per 100 lbs ice	Condenser water usage per 100 lbs ice
				70° Air/50°F Water / 21° Air/10°C Water	90° Air/70°F Water / 32° Air/21°C Water			
@ 90° Air/70°F Water (32° Air/21°C Water)								
Air Cooled	KDP-0500A	Dice	157 lbs (71.2 kgs)	502 lbs (228 kgs)	391 lbs (177 kgs)	5.5 ★	14.3 gal (54.1 L)	N/A
	KYP-0500A	Half-Dice	157 lbs (71.2 kgs)	521 lbs (236 kgs)	422 lbs (191 kgs)	5.0 ★	13.6 gal (51.5 L)	N/A
Water Cooled	KDP-0500W	Dice	159 lbs (72 kgs)	478 lbs (217 kgs)	419 lbs (190 kgs)	4.1	13.8 gal (52.2 L)	142 gal (538 L)
	KYP-0500W	Half-Dice	159 lbs (72 kgs)	522 lbs (237 kgs)	450 lbs (205 kgs)	3.6	13.8 gal (52.2 L)	142 gal (538 L)

R290 is a refrigerant grade propane which is naturally occurring with no ozone depletion potential and extremely low global warming potential.

★ Energy Star Model

Limited Commercial Warranty

Ice Maker Three (3) years parts and labor

Evaporator Five (5) years parts and labor

Compressor Five (5) years parts, three (3) years labor



2110 South 26th Street | Manitowoc, WI 54220 | United States
+1.920.682.0161 | 920.683.7589 Fax | manitowocice.com

All indicated Pentair trademarks and logos are property of Pentair. Third party registered and unregistered trademarks and logos are the property of their respective owners. ©2025 Pentair. All rights reserved. Maniowoc Ice reserves the right to make changes to the design or specifications without prior notice.

