



Project \_\_\_\_\_

Item \_\_\_\_\_ Quantity \_\_\_\_\_

Approved by \_\_\_\_\_ Date \_\_\_\_\_

AIA/SIS # \_\_\_\_\_



# ADMIRAL 44

Single Tank Rack Conveyor Dishwasher



# 233

Racks Per Hour

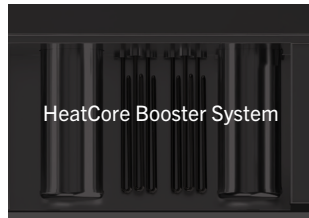

HeatCore Booster System



CrossFire™ Wash System



ENERGY STAR® 3.0 Certified

## STANDARD FEATURES

- Washes 233 racks (20" x 20") per hour
- ColorCorrect dish curtains
- CrossFire™ wash system
- Dual built-in HeatCore boosters
- ENERGY STAR® 3.0 certified
- InfoPanel multi-line display
- RackAware rack detection system
- ScrapShield oversized scrap screens
- StatusGlow LED indicator bar
- Automatic tank fill
- Detergent connection provision
- Door safety switches
- Dual point connection (single point optional)
- Elevated top mounted control panel
- End caps/pipe plugs secured to prevent loss
- Left or right hand configuration
- Low water protection
- Manifold clean-out brush
- Override switch for de-liming
- Standard frame drip proof motors
- T304 stainless steel construction
- Ventilation fan connection provision
- VFD controlled continuous drive conveyor
- Wash tank heat recovery system

## OPTIONS & ACCESSORIES

- 20" x 20" dish racks (peg or flat)
- Adjustable vent collars with damper controls
- Drain cooldown
- Left hand feed
- Power loader
- Power unloader
- Pressure reduction valve and wye strainer
- Rack limit switch
- Right hand feed
- Security package
- Single point connection (480V only)
- Vent cowl collar with adjustable damper controls

## SPECIFIER STATEMENT

Specified unit will be an Admiral 44 single tank rack conveyor dishwasher with recirculating wash system and fresh water final rinse. Features include CrossFire wash system, dual built-in HeatCore boosters, Energy Star 3.0 certification, InfoPanel multi-line display, RackAware rack detection, StatusGlow LED indicator bar and ScrapShield oversized scrap screens. Includes a one (1) year parts & labor warranty.

# TECHNICAL INFORMATION

## LEFT TO RIGHT

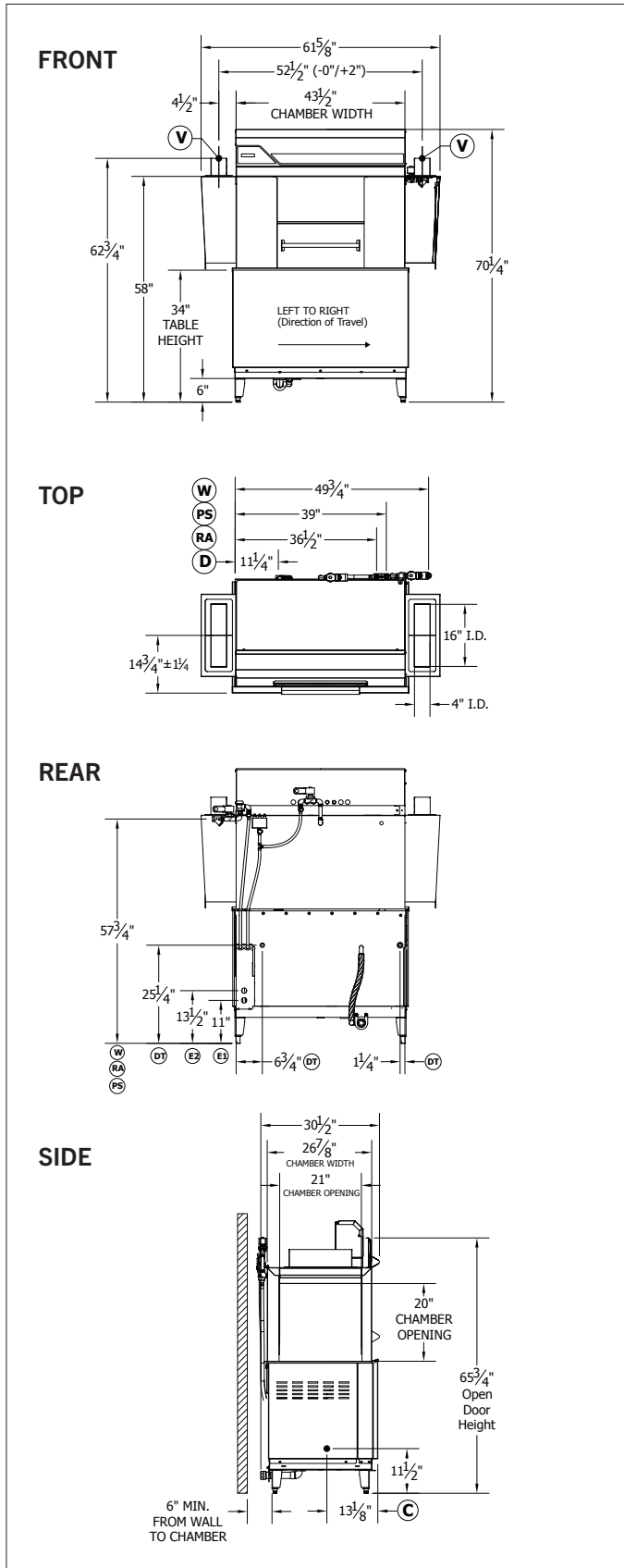

## RIGHT TO LEFT

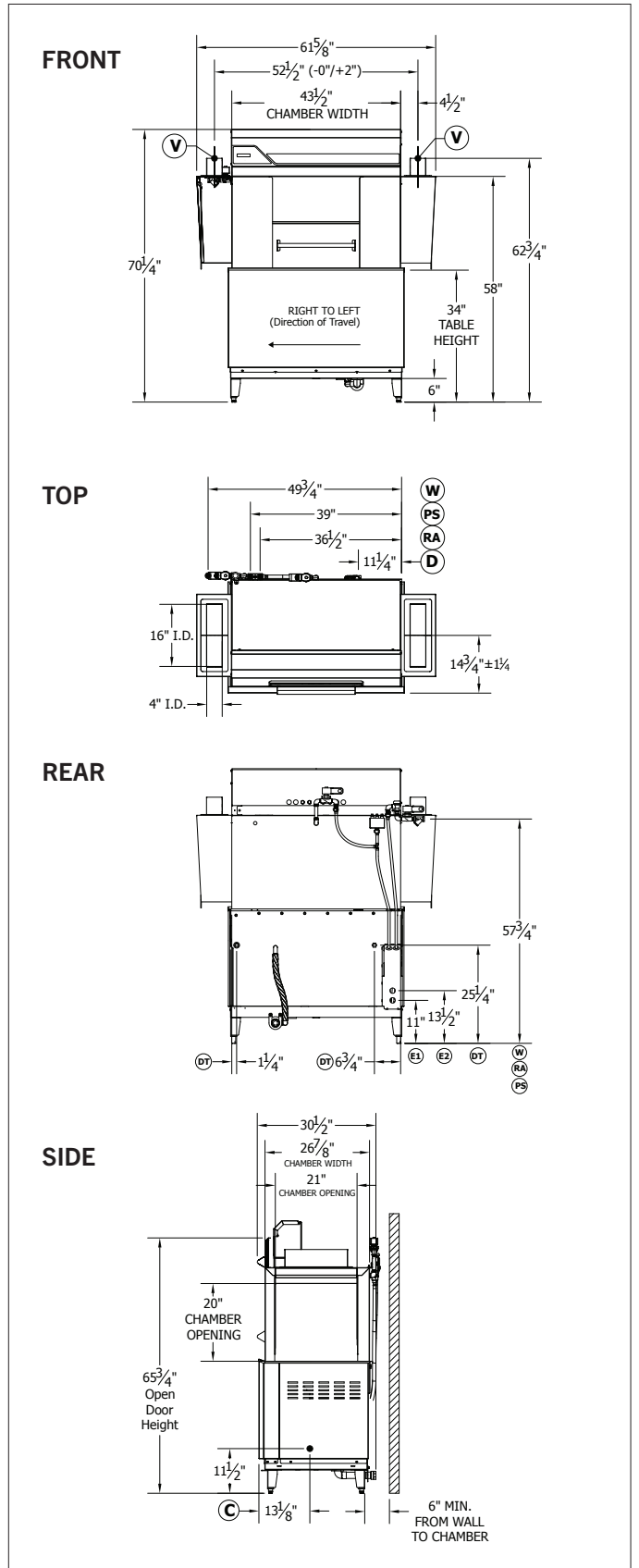

## SPECIFICATIONS

Capacity	Racks Per Hour	233
	Dishes Per Hour	5,225
	Meals Per Hour	200-400
Heating & Venting	Tank Heat	18 kW
	Booster Heat	29.4 kW
	Venting (Load End)	350 CFM
	Venting (Unload End)	350 CFM
Water	Water Inlet Temperature	110°F
	Water Consumption (20 PSI)	.63 gal/rack
	Wash Tank Capacity	33.75 gal
	Peak Drain Flow	9.0 gal/min
Other	Drive Motor HP	1/15
	Wash Motor HP	2.0
	Built-In Boosters (2)	Standard
	Shipping Weight	750

## ELECTRICAL

	Service Options	E1	E2
Electric Tank Heat (Dual Point)	208/60/3	56.5 A	81.6 A
	240/60/3	49.8 A	70.7 A
	480/60/3	25.0 A	35.4 A
	Service Options	Total Load	
Electric Tank Heat (Single Point)	480/60/3	61.5 A	

## LEGEND

	Label	Description	Note
Water	D	Drain Connection	1-1/2 FPT
	W	Hot Water Inlet (110 F Min)	1/2 FPT
Electrical	E1	Main Electrical (Single & 2-Point)	1-3/8 HOLE
	E2	Booster Electrical (2 Pt Only)	1-3/8 HOLE
	C	Conductivity Probe Location	7/8 HOLE
	DT	Detergent Insertion Points	7/8 HOLE
Chemical	PS	Pressure Switch Connection	1/4 FPT
	RA	Rinse Aid Connection	1/4 FPT
Other	V	Vent Collar & Dampers (Optional)	4" X 16"

## TABLE CONFIGURATION

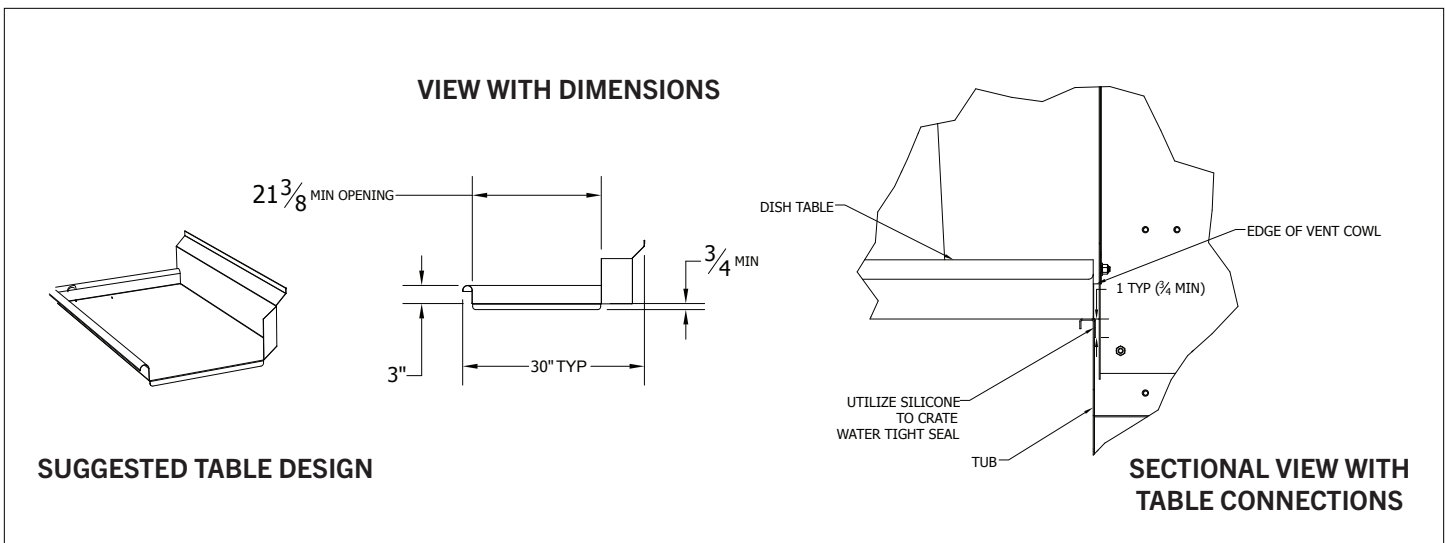

Contact Insinger Sales at 800-344-4802 for an installation drawing specific to your application.  
 Note: Due to product improvement we reserve the right to change information and specifications without notice.