

MODEL: IMD-ERV53 / IMD-ERV83
NARROW MERCHANDISER COOLERS.

IMD-ERV53



IMD-ERV83

General Strengths

- ✓ **Sanitation.** Quick ability to take off shelves and slides for interior cleaning.
- ✓ **Doors.** All doors include door gaskets, easy to remove and snap in.
- ✓ **Control systems.** Higher precision in managing temperature settings. Greater ability for the adjustment of temperatures ranges as per the end user's requirement.
- ✓ **100% Tested.** All condenser units are tested 100%, in helium chambers for refrigerant leak detections.
- ✓ **Certified.** Audited and Certified by **INTERTEK** for compliance with UL 471 and NSF 7. EQA audited and certified by internationally recognized firm. ISO 9001:2015 (Quality); ISO 14001:2015 (Environmental); ISO 45001:2018 (Prevention and Worker Safety)
- ✓ **Lighting.** LED lighting in cabinet sides reduces the energy consumption by 80% and 90% compared to a traditional bulb. Provides a much better light quality.



MODEL: IMD-ERV53 / IMD-ERV83

NARROW MERCHANDISER COOLERS.

STANDARD FEATURES

➤ **Exterior**

- Black Laminated Steel.
- Completely injected compact structure.
- Door lock.

➤ **Interior**

- Interior prepainted.
- LED lighting.

➤ **Doors**

- Triple chamber snap in door seals for easy removal.
- Black plastic handle included on the door.

➤ **Insulation**

- Polyurethane with high density 40kg/m³, CFSs free, zero ODP and low GWP.

➤ **Shelving**

- IMD-ERV53 - (5) interior shelves, dimensions WxD: 19-3/4 x 1-1/16 "(502x27 mm).
- IMD-ERV83- (5) interior shelves, dimensiond WxD: 19-3/4 x 1-3/32" (502x28 mm).
- Guides and shelves easy to take off for cleaning.

➤ **Refrigeration**

- Temperature and defrost regulated by a digital controller.
- Forced air evaporation system.
- Forced air condensation system.
- Evaporative pan.
- Evaporator coil coated with anti-corrosion material.
- Refrigeration capacity:
 IMD-ERV 53 - 1512 Btu/h (14°F) / 443W (-10°C)
 IMD-ERV 83 -2120 Btu/h (14°F) / 621W (-10°C)

OPTIONAL FEATURES

- ✓ Set of 2" Casters, front locking
- ✓ Electrical connection is 230 V / 1ph / 50Hz (plug type varies).
 Models;
 - IMD-ERV53: 1,10 A.
 - IMD-ERV83: 3,39 A.
- ✓ Electrical connection is 2230 V / 1ph / 60Hz (plug type varies).
- ✓ RGB LED lighting.

➤ **Electrical**

- Cord and NEMA 5-15P plug,
- Electrical connection is 115 V / 1ph / 60 Hz.



Project: _____
 Location: _____
 Item #: _____ Quantity: _____
 Model #: _____

MODEL: IMD-ERV53 / IMD-ERV83 **NARROW MERCHANDISER COOLERS.**

MODELS	Dimensions (inches) (mm)			Doors	Shelves	Ref.	Ref. Weight (Lbs.) (gr.)	Temperature Range (°F) (°C)	Cond. Unit	Capacity (Cu.Ft.) (L)	Case Amps 115V	Crated weight (Lbs.) (Kg.)
	W	D	H									
IMD-ERV53	23-5/8 (601)	20-1/8 (510)	73-5/8 (1870)	1	5	R290	0,17 (90)	39 °F/54 °F (+4°C/+12°C)	1/4	10 (280)	3,50	152 70
IMD-ERV83	35-1/2 (900)	20-1/8 (510)	73-3/4 (1872)	2	10	R290	0,24 (110)	39 °F/54 °F (+4°C/+12°C)	1/3	15 (435)	4,98	202 92

ELEVATION **RIGHT VIEW** **PLANT VIEW**

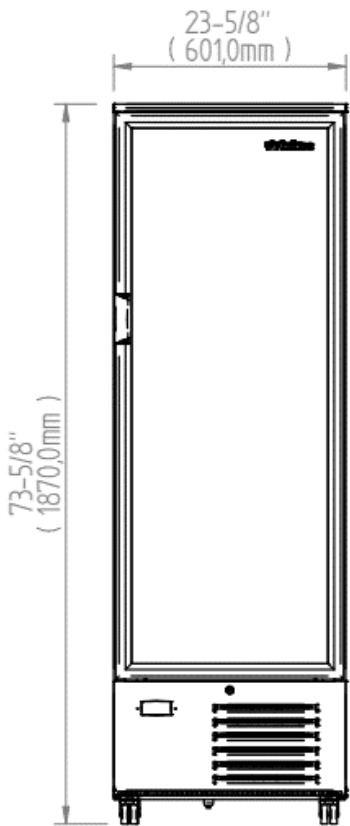

IMD-ERV53

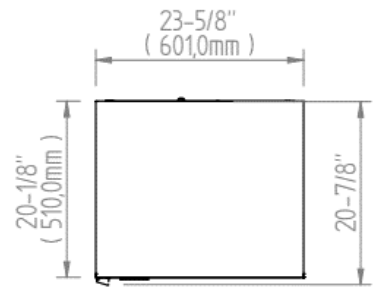
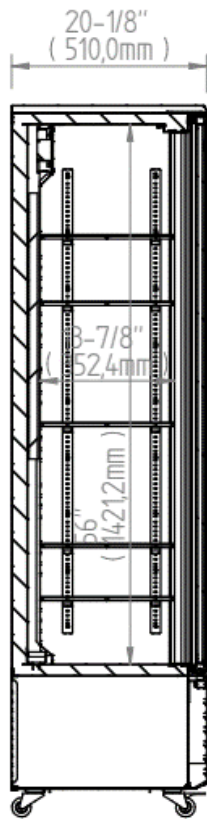

Review:00 Date: 07/31/2024 IMD-ERV53_83

ETL LISTED TO UL471 STANDARD AND SANITATION CLASSIFIED TO NSF7 – WE RESERVE THE RIGHT TO CHANGE SPECIFICATIONS WITHOUT PRIOR NOTICE

Project: _____
 Location: _____
 Item #: _____ Quantity: _____
 Model #: _____

MODEL: IMD-ERV53 / IMD-ERV83

NARROW MERCHANDISER COOLERS.

ELEVATION

RIGHT VIEW

PLANT VIEW

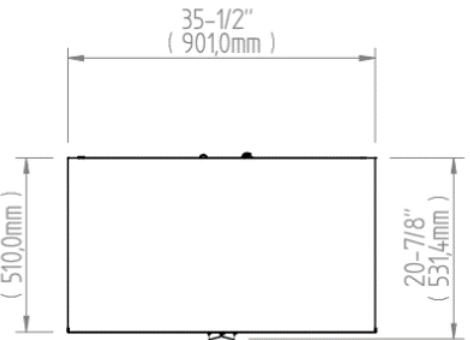
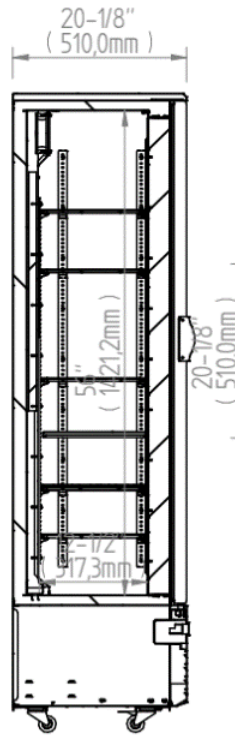
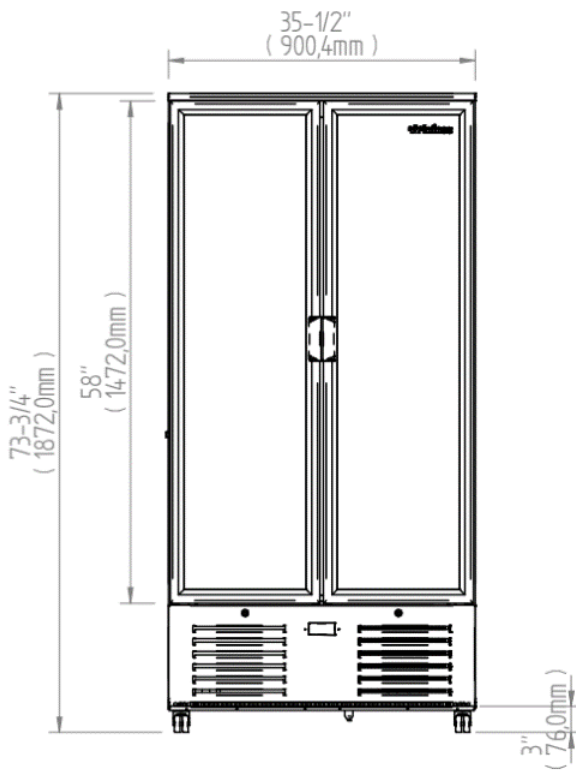

IMD-ERV83