

MODEL: IDC-VC1400_1400B
IDC-VC2010_2010B

VISION SERIES COUNTER DISPLAY CASE



IDC-VC1400



IDC-VC2010B

GENERAL FEATURES

- ✓ **Higher energy efficiency.** R290 refrigerant with electric fans, LED lighting and evaporative tray without electric resistances.
- ✓ **Sanitation.** Our units feature a hygienic design with rounded corners that have a large radius, making them easy to clean. Additionally, the shelves and runners inside the display can be quickly removed for thorough interior cleaning. Each unit is equipped with a trap at the bottom to facilitate cleaning.
- ✓ **Doors.** Self-closing door system features a permanent pressure mechanism, ensuring a secure closure every time. Additionally, a convenient 'stay open' feature engages when the door remains open at 95 degrees or beyond. Our doors also include triple chamber door gaskets that are easy to remove and snap in, ensuring an effective seal. Plus, for added flexibility, our doors are field reversible, allowing for easy installation and use in a variety of settings.
- ✓ **Control System.** Our temperature management system offers unparalleled precision, allowing for highly accurate temperature settings. With greater flexibility in adjusting temperature ranges, our system can be tailored to meet the unique needs of each end user. This ensures optimal performance and maximum satisfaction with every use.
- ✓ **Lighting.** LED lighting in the canopy and cabinet sides reduces the energy consumption by 80% to 90% compared to a traditional bulb, better light quality.
- ✓ **100% Tested.** All condenser units are 100% tested, in helium chambers for refrigerant leak detections.
- ✓ **Certified.** Audited and Certified by INTERTEK for compliance with UL 471 and NSF 7.



**MODEL: IDC-VC1400_1400B
 IDC-VC2010_2010B** **VISION SERIES COUNTER DISPLAY CASE**

STANDARD FEATURES

➤ **Exterior**

- AISI 304 Stainless Steel / Black Laminated Steel model B.
- AISI 304 Stainless Top.

➤ **Interior**

- AISI 304 Stainless Steel.
- Wide rounded corners to aid cleaning.
- LED lighting.
- Internal drain trap for easy cleaning.

➤ **Doors**

- Double pane rear glass doors.
- Self – closing door with stay open feature.
- Stainless Steel heavy-duty hinges.
- Triple chamber snap in door gaskets for easy removal and cleaning.

➤ **Insulation**

- CFC – Free polyurethane insulation, entire cabinet structure is foamed-in using a high- density polyurethane insulation.
- Low GWP & Zero ODP effect.

OPTIONAL FEATURES

- ✓ Electrical connections is:
 230 V / 1 ph / 50Hz (plug type varies), models
 IDC-VC1400: 3,30 A
 IDC-VC2010: 3,32 A.
- ✓ Rear solid doors.

➤ **Shelving**

- (4) Plastic coated wire shelves - VC1400_B.
- (6) Plastic coated wire shelves – VC2100_B.
- Set of Stainless Steel shelf brackets.
- Easy remove for cleaning.
- Dimensions WxD: 24-7/32”x 17-3/4” (615x400 mm).

➤ **Refrigeration**

- Temperature regulated by digital control.
- Stainless Steel evaporative pan.
- Evaporator coil coated with anti-corrosion material 100% polyester.
- Refrigeration capacity:
 IMD-VC1400 - 2342,67 Btu/h (14°F) / 687 W (-10°C).
 IMD-VC1400B - 2342,67 Btu/h (14°F) / 687 W (-10°C).
 IMD-VC2010B – 2342,67 Btu/h (14°F) / 687W (-10°C).
 IMD-VC2010 – 2342,67 Btu/h (14°F) / 687W (-10°C).

➤ **Electrical**

- Cord and NEMA 5-15P plug.
- Electrical connection is 115V/ 1ph / 60 Hz.



➤ **ETL Listen to UL471 Standard and Sanitation classified to NSF7.**

**MODEL: IDC-VC1400_1400B
 IDC-VC2010_2010B** **VISION SERIES COUNTER DISPLAY CASE**

MODELS	Dimensions (inches) (mm)			Doors	Shelves	Ref.	Ref.Weight (Lbs.) (gr.)	Temperature Range (°F) (°C)	Cond. Unit (H.P)	Capacity (Cu.Ft.) (L)	Case Amps 115V	Net weight (Lbs.)
	W	D	H									
IDC- VC1400	54-1/2 (1.384)	29-3/8 (740)	41-5/8 (1.060)	2	2/2	R290	0,20 (80)	35 °F/41 °F (0°C/+16°C)	1/3	16,6 (470)	9,61	343 (156)
IDC- VC1400B	54-1/2 (1.384)	29-3/8 (740)	41-5/8 (1.060)	2	2/2	R290	0,20 (80)	35 °F/41 °F (0°C/+16°C)	1/3	16,6 (470)	9,61	343 (156)
IDC-VC2010	79-1/8 (2.011)	29-3/8 (740)	41-5/8 (1.060)	3	2/3	R290	0,20 (100)	35°F/41 °F (0°C/+16°C)	1/3	25,07 (710)	9,66	467 (212)
IDC-VC2010B	79-1/8 (2.011)	29-3/8 (740)	41-5/8 (1.060)	3	2/3	R290	0,20 (100)	35°F/41 °F (0°C/+16°C)	1/3	25,07 (710)	9,66	467 (212)

ELEVATION **RIGHT VIEW**

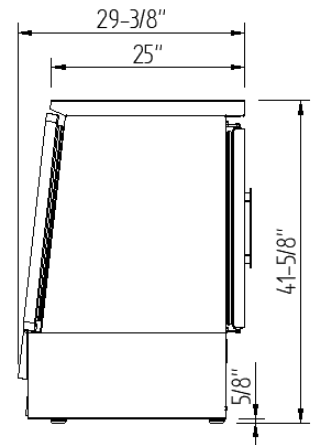
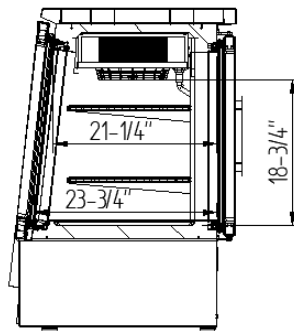
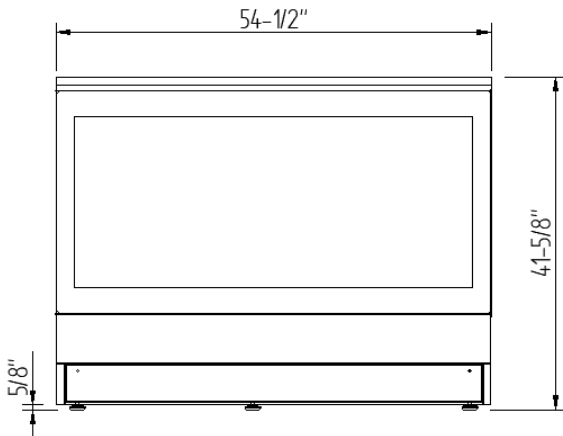

PLAN VIEW

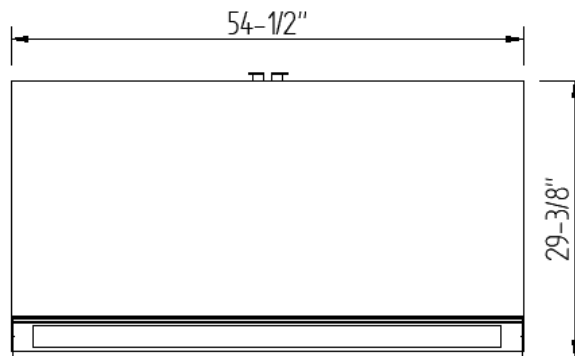

IDC-VC1400_B

Rev: 01 Date: 09/03/2024 IDC- VC1400/2010_B

ETL LISTED TO UL471 STANDARD AND SANITATION CLASSIFIED TO NSF7 – WE RESERVE THE RIGHT TO CHANGE SPECIFICATIONS WITHOUT PRIOR NOTICE

Project: _____
 Location: _____
 Item #: _____ Quantity: _____
 Model #: _____

MODEL: **IDC-VC1400_1400B**
IDC-VC2010_2010B

VISION SERIES COUNTER DISPLAY CASE

ELEVATION **RIGHT VIEW**

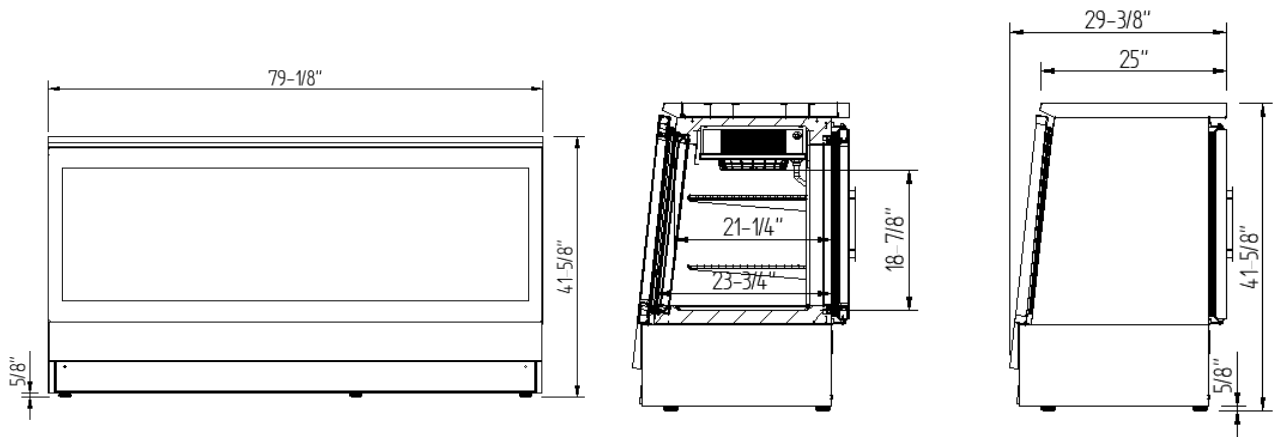

PLAN VIEW

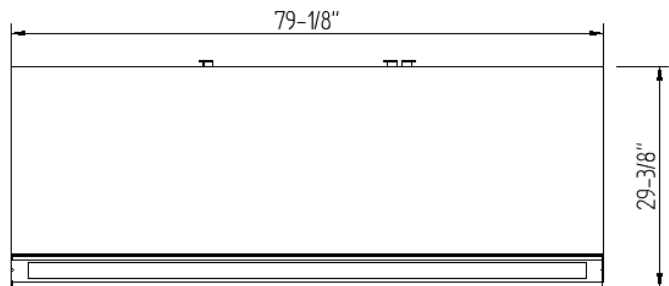

IDC-VC2010_B