

MODEL: IBC-ABT31S/IBC-ABT51L_51C
IBC-ABT61L / IBC-ABT71L_71M

Blast Chillers and Shock Freezers.

GENERAL FEATURES



- ✓ **Higher energy efficiency.** R290 refrigerant with electronic fans, LED lighting and evaporative tray without electric resistances.
- ✓ **Sanitation.** Our units feature heaters hygienic design with rounded corners that have a large radius, making them easy to clean. Additionally, the shelves and slides can be quickly removed for thought interior cleaning. Each unit is equipped with a drain at the bottom to facilitate cleaning.
- ✓ **Doors.** Self-closing door system features a permanent pressure mechanism, ensuring a secure closure every time. Additionally, a convenient 'stay open' feature engages when the door remains open at 95 degrees or beyond. Our doors also include triple chamber door gaskets that are easy to remove and snap in, ensuring an effective seal. Plus, for added flexibility, our door are field reversible, allowing for easy installation and use in a variety of settings.
- ✓ **Control System.** Our temperature management system offers unparalleled precision, allowing for highly accurate temperature settings. With greater flexibility in adjusting temperature ranges, our system can be tailored to meet the unique needs of each end user. This ensures optimal performance and maximum satisfaction with every use.
- ✓ **100% Tested.** All condenser units are 100% tested, in helium chambers for refrigerant leak detections.
- ✓ **Certified.** Audited and Certified by INTERTEK for compliance with UL 471 and NSF 7.



Review:02 Date: 07/11/2025 IBC- ABT_31S_51L_51C_61C_71M_71L

ETL LISTED TO UL471 STANDARD AND SANITATION CLASSIFIED TO NSF7 – WE RESERVE THE RIGHT TO CHANGE SPECIFICATIONS WITHOUT PRIOR NOTICE

**MODEL: IBC-ABT31S/IBC-ABT51L_51C
IBC-ABT61C / IBC-ABT71L_71M**

Blast Chillers and Shock Freezers.

STANDARD FEATURES

➤ **Compatible with any oven.**

- **IBC-ABT31S** – 3 Half (12x20”) Pans.
- **IBC-ABT51L** – 5 Half (12x20”) or 5 Full Size (18x26”) Pans.
- **IBC-ABT51C** – 5 Half (12x20”) or 5 Full Size (18x26”) Pans.
- **IBC-ABT61C** – 6 Half (12x20”) Pans.
- **IBC-ABT71L** – 7 Half (12x20”) or 7 Full Size (18x26”) Pans.
- **IBC-ABT71M** - 7 Half (12x20”) or 7 Full Size (18x26”) Pans.

➤ **Exterior**

- AISI 430 Stainless Steel.
- Compliant with HACCP regulations.
- Levelling feet (**IBC-ABT31S** Only).

➤ **Interior**

- AISI 430 Stainless Steel.
- Sealed interior floors and rounded cabinet corners.
- Internal drain plug for easy cleaning.
- Includes an easy to use heated conical product probe.

➤ **Insulation**

- CFC Free polyurethane insulation, entire cabinet structure is foamed-in using a high-density.
- Low GWP & Zero ODP effect.

➤ **Doors**

- Polyurethane insulated door.
- Self closing door with stay open feature.
- Heavy-duty hinges with horizontal and vertical adjustment.
- Triple chamber snap in door gaskets for easy removal and cleaning.
- Heated door frame to avoid accumulation of ice.

➤ **Refrigeration**

- User- friendly interface.
- Evaporator coil coated with anti – corrosion material 100% polyester.
- Forced air refrigeration system.
- Refrigeration capacity:
 - IBC-ABT31S:** 4.424 Btu/h (-13°F) / **1.296 W (-25°C).**
 - IBC-ABT51L:** 7.313 Btu/h (-13°F) / **2.142 W (-25°C).**
 - IBC-ABT51C:** 7.313 Btu/h (-13°F) / **2.142 W (-25°C).**
 - IBC-ABT61C:** 6.162 Btu/h (-13°F) / **1.805 W (-25°C).**
 - IBC-ABT71L:** 7.647 Btu/h (-13°F) / **2.240 W (-25°C).**
 - IBC-ABT71M:** 7.647 Btu/h (-13°F) / **2.240 W (-25°C).**
- **Blast chilling:** +149°F (+65°C) to +37°F (3°C) in less than 90 minutes.
- **Blast freezing:** +149°F (+65°C) to 0°F (-18°C) in less than 4 hours.
- **Freezing ing capacity / cooling capacity:** 132 lb - **60Kg** / 242 lb - **110Kg**

➤ **Digital Control**

- Interactive control screen & menu.
- Up to 99 different customized cycles.
- USB connection. 

➤ **Electrical**

- **Cord and NEMA 5-15P plug.**
- **Electrical connections is 115 V / 1ph / 60 Hz.**
- **Must be connected to 20 Amp. Circuit breaker!**

➤ **ETL Listed to UL471 Standard and Sanitation classified to NSF7.**

OPTIONAL FEATURES

- ✓ Stainless Steel wire shelf.
- ✓ Additional slides kits.
- ✓ Set of 6” legs, height adjustable from 5” to 8”.

Review:02 Date: 07/11/2025 IBC-ABT_31S_51L_51C_61C_71M_71L

ETL LISTED TO UL471 STANDARD AND SANITATION CLASSIFIED TO NSF7 – WE RESERVE THE RIGHT TO CHANGE SPECIFICATIONS WITHOUT PRIOR NOTICE

**MODEL: IBC-ABT31S/IBC-ABT51L_51C
IBC-ABT61C / IBC-ABT71L_71M**

Blast Chillers and Shock Freezers.

MODELS	Dimensions (inches) (mm)			Doors	Freezing capacity/ Cooling capacity	Shelves	Ref.	Ref. Weig ht (Lbs.) (gr.)	Temperature Range (°F) (°C)	Cond. Unit (H.P)	Capacity (Cu.Ft.) (L)	Chilling / freezing capacity (Kg)	Case Amps 115V	Net weight (Lbs.) (Kg.)
IBC-ABT31S	28-3/8 (721)	28 (711)	21-1/4 (545)	1	22/11	3	R290	0,31 (140)	37,4°F/ -36,4°F (+3°C / -38°C)	3/4	2,40 (68)	22/11 (10/5)	3,53	161 (73)
IBC-ABT51L	33 (837)	35-1/4 (870)	39-1/8 (967)	1	44/26	5	R290	0,29 (130)	37,4°F/ -36,4°F (+3°C / -38°C)	1-1/4	4,41 (125)	44/26 (20/12)	15,04	293 (133)
IBC-ABT51C	33 (837)	28-1/2 (724)	31-1/2 (825)	1		5	R290	0,31 (140)	37,4°F/ -36,4°F (+3°C / -38°C)	1-1/4	3,35 (95)		15,94	275 (125)
IBC-ABT61C	20 (508)	34-1/8 (863)	41-3/4 (1057)	1		6	R290	0,31 (140)	37,4°F/ -36,4°F (+3°C / -38°C)	1-1/4	3,00 (86)		14,69	227 (103)
IBC-ABT71L	33 (837)	35-1/4 (870)	44-1/2 (1.127)	1	66/40	7	R290	1,65 (750)	37,40 °F/ - 36,40°F (+3°C / -38°C)	1-1/4	5,65 (160)	66/40 (30/18)	13,52	337 (153)
IBC-ABT71M	57-13/16 (1468)	27-9/16 (700)	36-5/8 (940)	1		7	R290	2,20 (1.000)	37,40 °F/ - 36,40°F (+3°C / -38°C)	1-1/4	4,5 (130)		13,45	317 (144)

PLAN VIEW

ELEVATION

RIGHT VIEW

PLANT VIEW

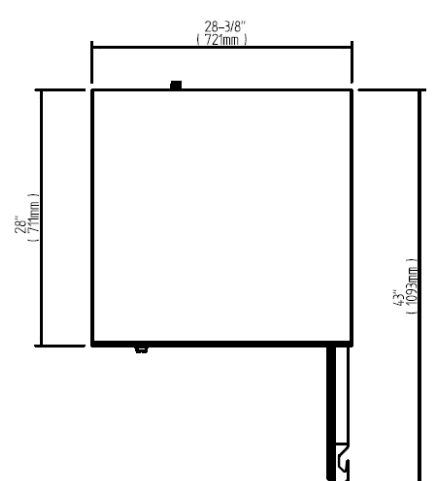
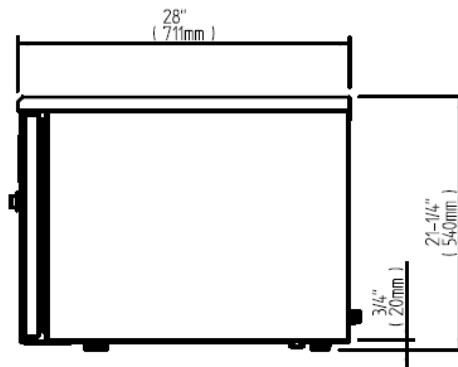
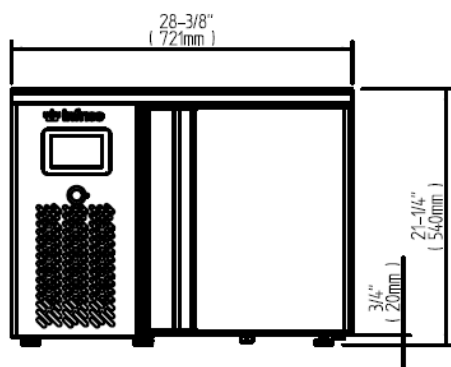

IRR-ABT31S

Review:02 Date: 07/11/2025 IBC- ABT_31S_51L_51C_61C_71M_71L

ETL LISTED TO UL471 STANDARD AND SANITATION CLASSIFIED TO NSF7 - WE RESERVE THE RIGHT TO CHANGE SPECIFICATIONS WITHOUT PRIOR NOTICE

**MODEL: IBC-ABT31S/IBC-ABT51L_51C
IBC-ABT61C / IBC-ABT71L_71M**

Blast Chillers and Shock Freezers.

ELEVATION

RIGHT VIEW

PLANT VIEW

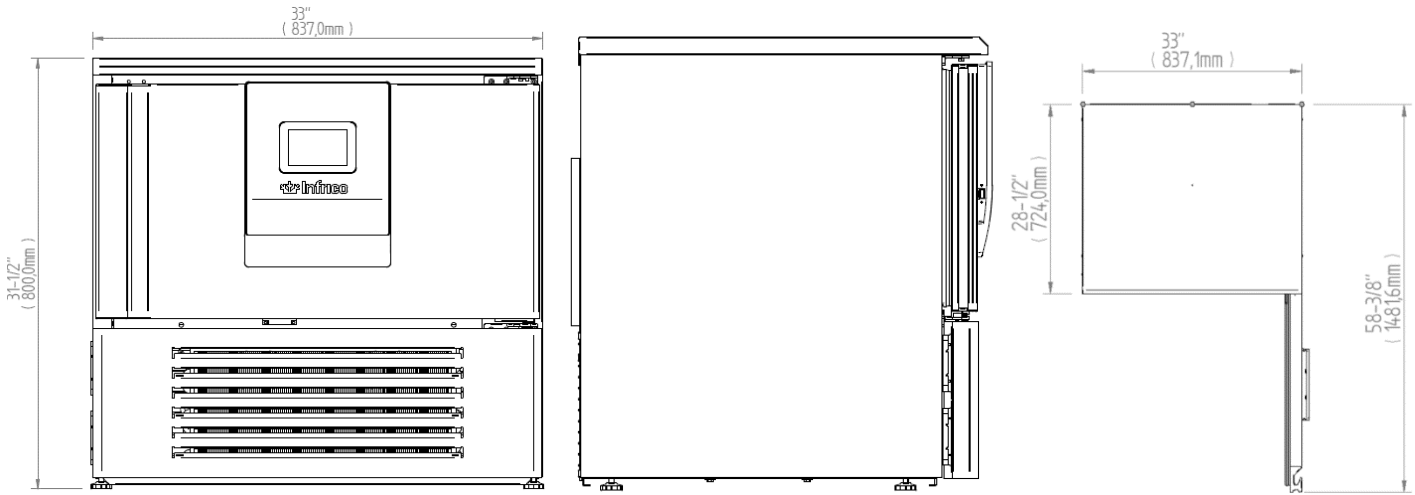

IRR-ABT51C

ELEVATION

RIGHT VIEW

PLANT VIEW

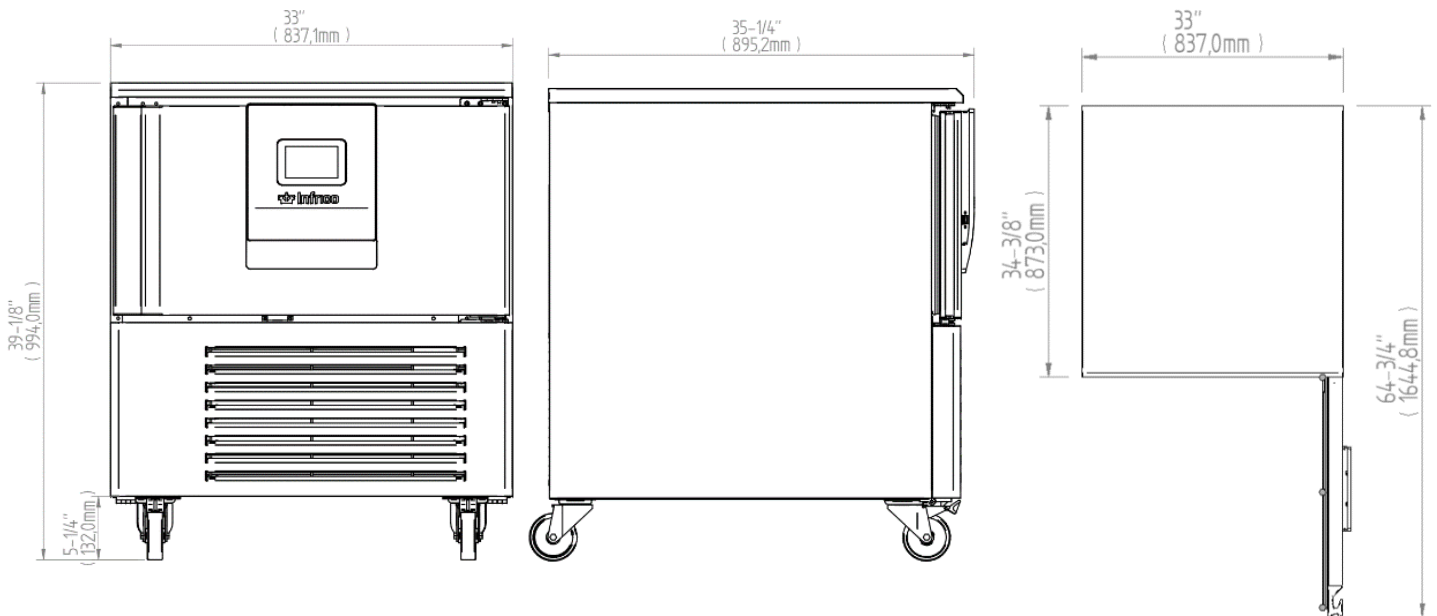

IRR-ABT51L

Review:02 Date: 07/11/2024 IBC- ABT_31S_51L_51C_61C_71M_71L

ETL LISTED TO UL471 STANDARD AND SANITATION CLASSIFIED TO NSF7 - WE RESERVE THE RIGHT TO CHANGE SPECIFICATIONS WITHOUT PRIOR NOTICE

**MODEL: IBC-ABT31S/IBC-ABT51L_51C
IBC-ABT61C / IBC-ABT71L_71M**

Blast Chillers and Shock Freezers.

ELEVATION

RIGHT VIEW

PLANT VIEW

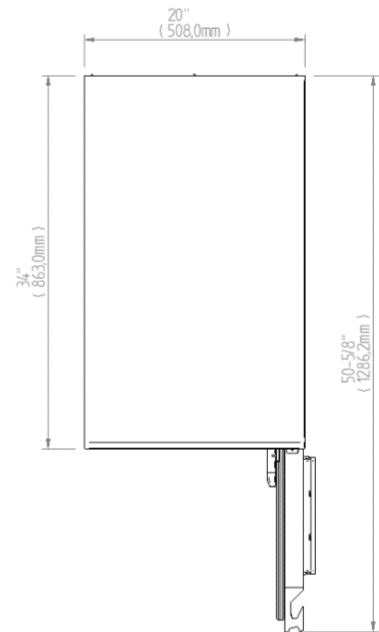
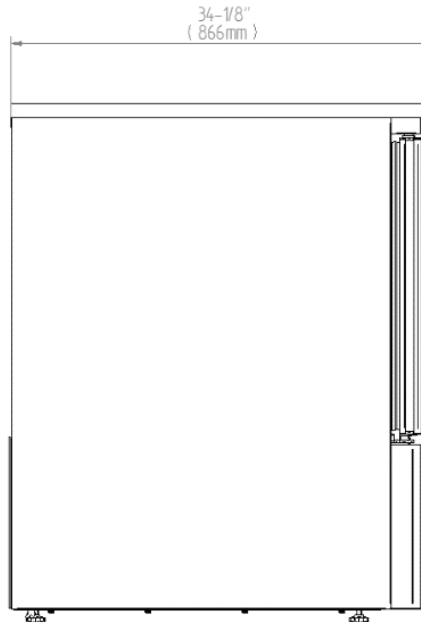
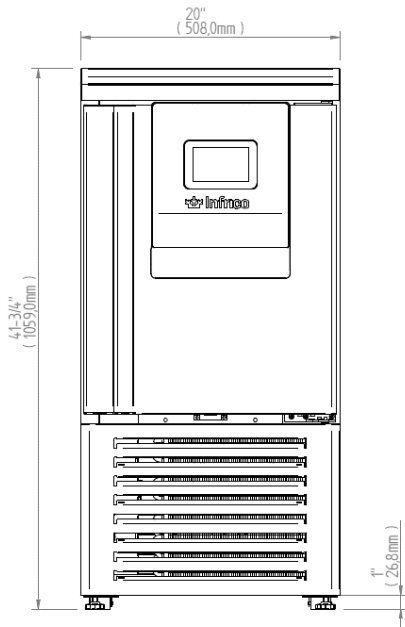

IRR-ABT61C

ELEVATION

RIGHT VIEW

PLANT VIEW

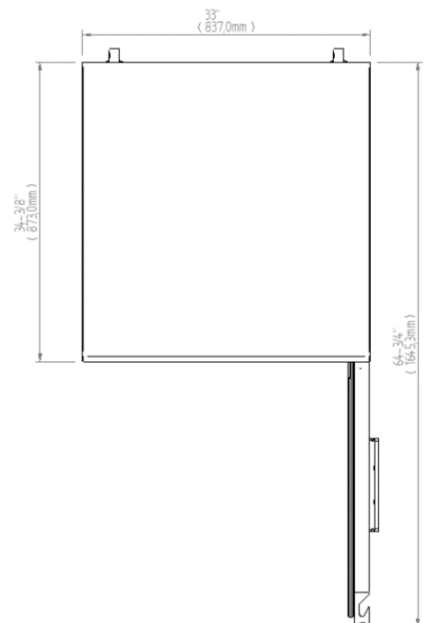
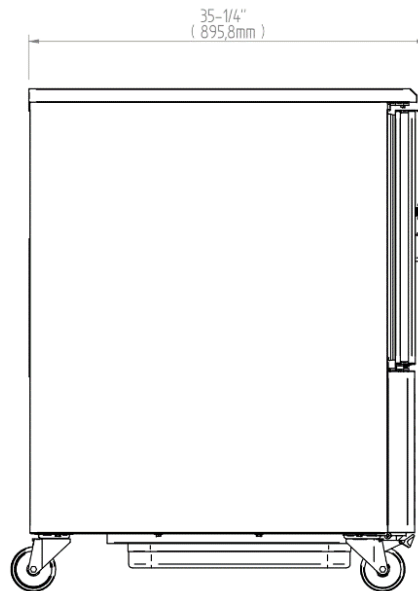
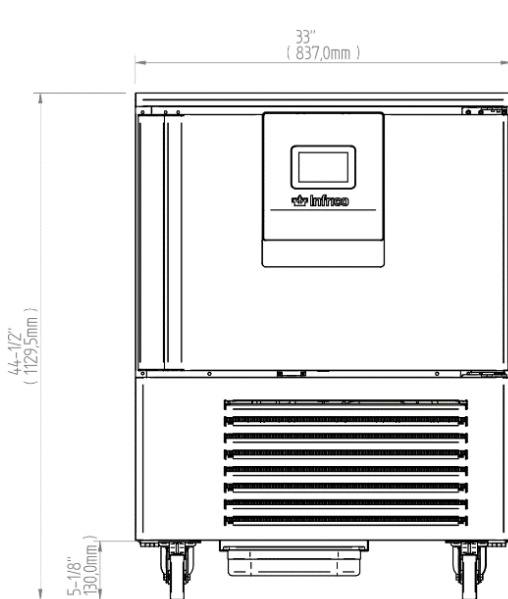

IRR-ABT71L

Review:02 Date: 07/11/2025 IBC- ABT_31S_51L_51C_61C_71M_71L

ETL LISTED TO UL471 STANDARD AND SANITATION CLASSIFIED TO NSF7 - WE RESERVE THE RIGHT TO CHANGE SPECIFICATIONS WITHOUT PRIOR NOTICE

MODEL: IBC-ABT31S/IBC-ABT51L_51C
IBC-ABT61C / IBC-ABT71L_71M

Blast Chillers and Shock Freezers.

ELEVATION

RIGHT VIEW

PLANT VIEW

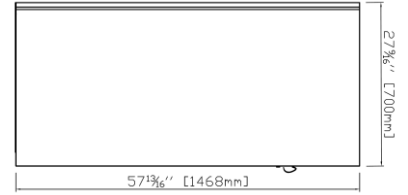
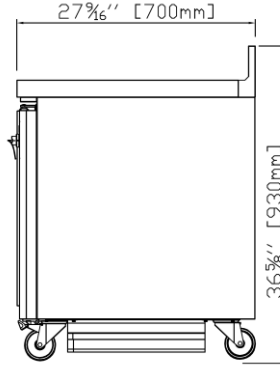
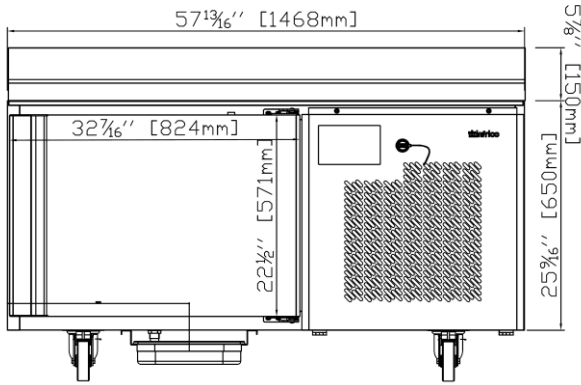

IRR-ABT71M

