

MODEL: IBC-ABT201C_202C
 IBC-ABT201P_202P

Blast Chillers and Shock Freezers.

GENERAL FEATURES

ABT20 2P



- ✓ **Blast Chiller Functions.** Experience the game-changing benefits of our advanced blast chiller functions. Swiftly reduce core temperatures, preserving freshness, hygiene, and quality while minimizing bacterial growth. Elevate your food preservation standards with ease and confidence.
- ✓ **Sanitation.** Our cabinets prioritize sanitation with rounded corners for easy cleaning.
- ✓ **Doors.** Self-closing door system features a permanent pressure mechanism, ensuring a secure closure every time. Additionally, a convenient 'stay open' feature engages when the door remains open at 95 degrees or beyond. Our doors also include triple chamber door gaskets that are easy to remove and snap in, ensuring an effective seal.
- ✓ **Control System.** Our temperature management system offers unparalleled precision, allowing for highly accurate temperature settings. With greater flexibility in adjusting temperature ranges, our system can be tailored to meet the unique needs of each end user. This ensures optimal performance and maximum satisfaction with every use.
- ✓ **100% Tested.** All condenser units are 100% tested, in helium chambers for refrigerant leak detections.
- ✓ **Certified.** Audited and Certified by INTERTEK for compliance with UL 471 and NSF 7.



Review:02 Date: 07/02/2023 IBC-ABT_C_P
 ETL LISTED TO UL471 STANDARD AND SANITATION CLASSIFIED TO NSF7 – WE RESERVE THE RIGHT TO CHANGE SPECIFICATIONS WITHOUT PRIOR NOTICE

MODEL: IBC-ABT201C_202C
IBC-ABT201P_202P

Blast Chillers and Shock Freezers.

STANDARD FEATURES

➤ **Compatible with any oven American pastry rack on wheels.**

➤ **Exterior**

- AISI 304 Stainless Steel.
- Compliant with HACCP regulations.

➤ **Doors**

- Polyurethane insulated door.
- Self-closing door with stay open feature.
- Triple chamber snap in door gaskets for easy removal and cleaning.
- Heated door frame to avoid accumulation of ice.

➤ **Interior**

- AISI 304 Stainless Steel.
- Sealed interior floors and rounded cabinet corners.
- Includes a heated conical probe which is easy to use and remove.

➤ **Insulation**

- CFC-Free polyurethane, entire cabinet structure is foamed-in using a high – density polyurethane insulation.
- Low GWP & Zero ODP effect.

➤ **Doors**

- Polyurethane insulated door.
- Self closing door with stay open feature.
- Stainless Steel heavy-duty hinges.
- Triple chamber snap in door gaskets for easy removal and cleaning.
- Heated door frame to avoid accumulation of ice.

➤ **Refrigeration**

- Control panel with an easy to read screen and menu.
- Manual defrost during cycles and automatic defrost during maintenance.
- Evaporator coil coated with anti – corrosion material 100% polyester.
- Forced air refrigeration system.
- **Blast chilling:** + 149 °F (65 °C) to + 37°F (3°C) in less than 90 minutes.
- **Blast freezing:** +149 °F (65 °C) to 0°F (-18 °C) in less than 4 hours.
- **Refrigeration capacity:**
 IBC-ABT201C: 34.390 Btu/h (-13°F) / 10.073 W (-25°C).
 IBC-ABT202C: 34.390 Btu/h (-13°F) / 10.073 W (-25°C).
 IBC-ABT201P: 34.390 Btu/h (-13°F) / 10.073 W (-25°C).
 IBC-ABT202P: 34.390 Btu/h (-13°F) / 10.073 W (-25°C).

➤ **Digital Control**

- Interactive control screen & menu.
- Up to 99 different customized cycles.
- USB connection.



➤ **Electrical**

- **Cord only included.**
- **Must be connected to 30 Amp. Circuit breaker!**

➤ **ETL Listed to UL471 Standard and Sanitation classified to NSF7.**

**MODEL: IBC-ABT201C_202C
 IBC-ABT201P_202P**

Blast Chillers and Shock Freezers.

ELEVATION

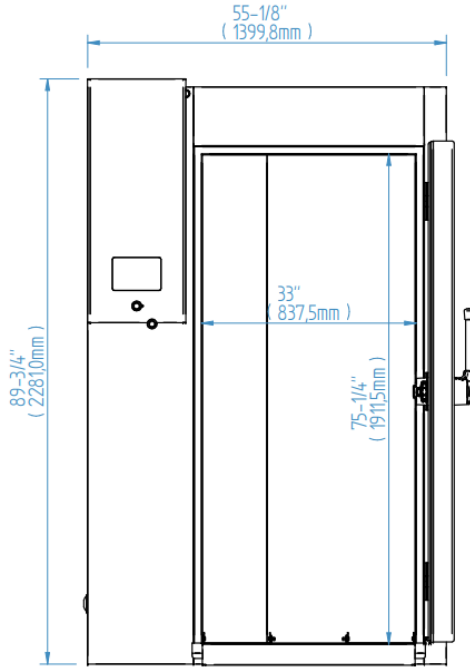

RIGHT VIEW

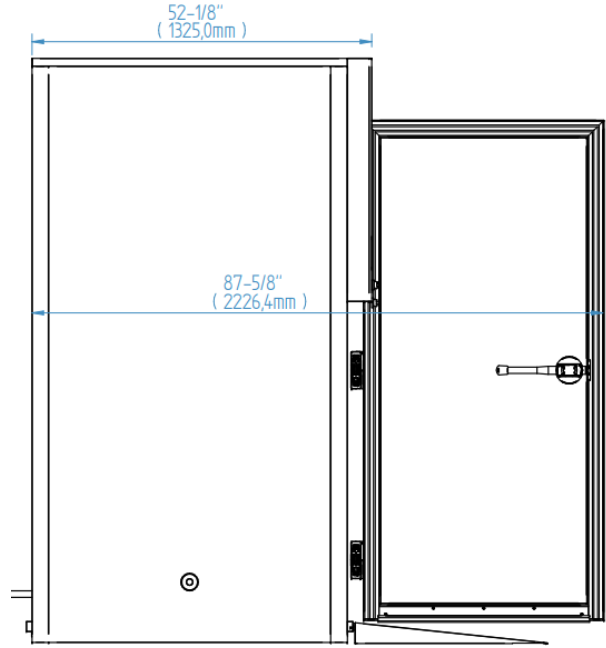

PLANT VIEW

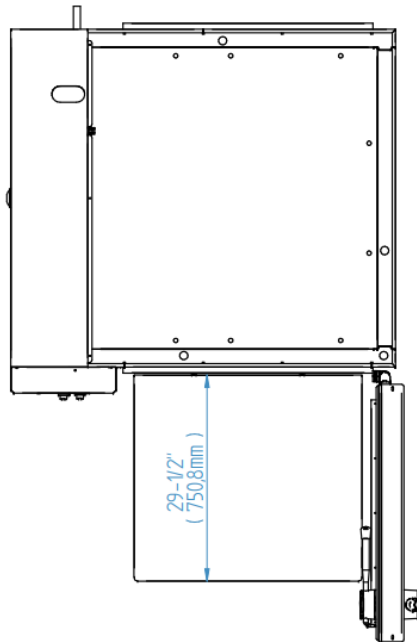

IBC-ABT202C

Review:02 Date: 07/02/2023 IBC-ABT_C_P

ETL LISTED TO UL471 STANDARD AND SANITATION CLASSIFIED TO NSF7 – WE RESERVE THE RIGHT TO CHANGE SPECIFICATIONS WITHOUT PRIOR NOTICE

MODEL: IBC-ABT201C_202C
IBC-ABT201P_202P

Blast Chillers and Shock Freezers.

ELEVATION

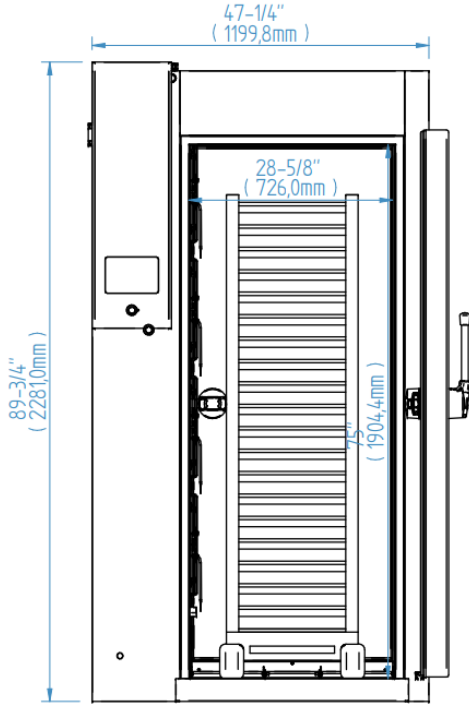

RIGHT VIEW

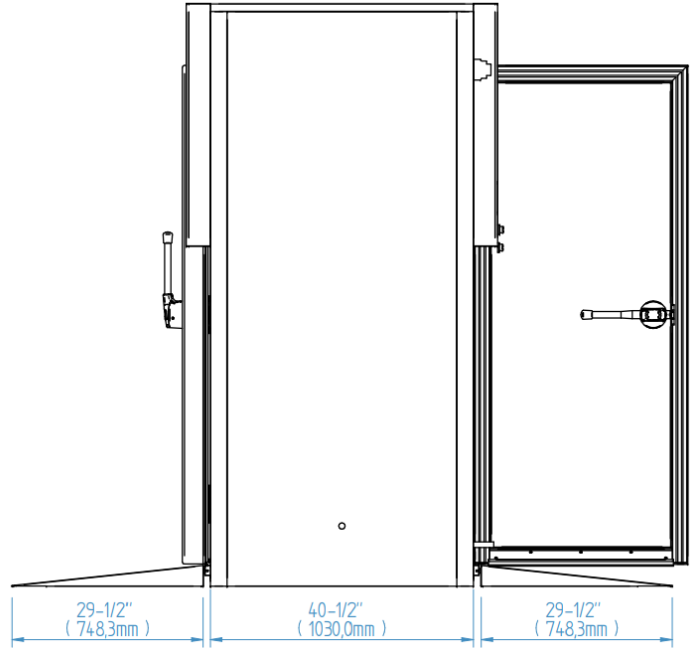

PLANT VIEW

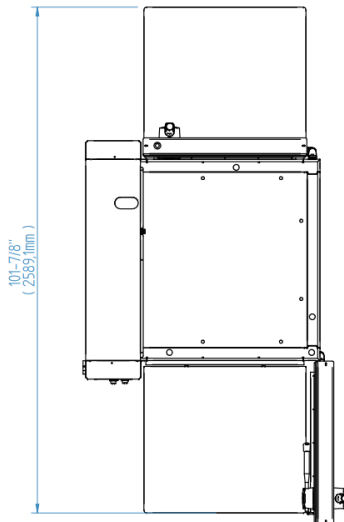

IBC-ABT201P

Review:02 Date: 07/03/2023 IBC-ABT_C_P

ETL LISTED TO UL471 STANDARD AND SANITATION CLASSIFIED TO NSF7 – WE RESERVE THE RIGHT TO CHANGE SPECIFICATIONS WITHOUT PRIOR NOTICE



INFRICO-North America Corporate División
 11200NW 25th St ste 123, Sweetwater, FL, 33172
 (305) 777 9599

www.infrico.us
sales@infrico.com

MODEL: IBC-ABT201C_202C
IBC-ABT201P_202P

Blast Chillers and Shock Freezers.

ELEVATION

RIGHT VIEW

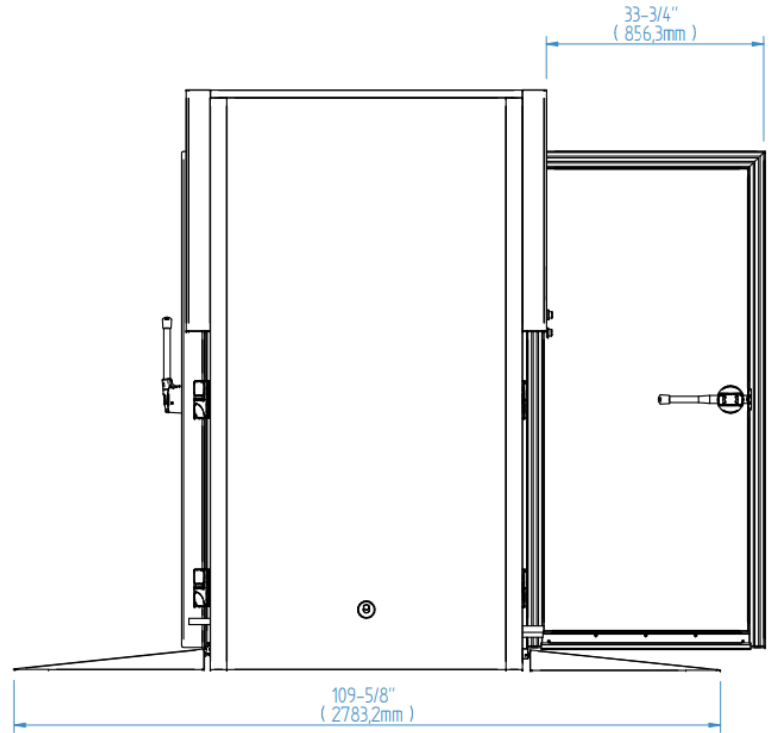
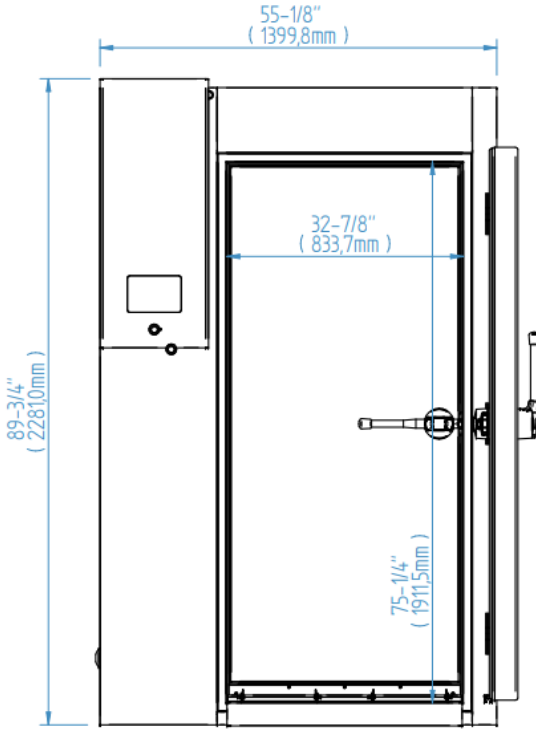

PLAN VIEW

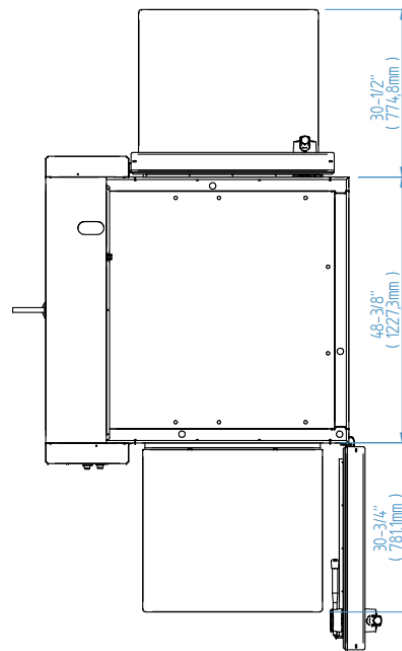

IBC-ABT202P

Review:02 Date: 07/03/2023 IBC-ABT_C_P

ETL LISTED TO UL471 STANDARD AND SANITATION CLASSIFIED TO NSF7 – WE RESERVE THE RIGHT TO CHANGE SPECIFICATIONS WITHOUT PRIOR NOTICE