



Project: _____
Location: _____
Item #: _____
Quantity: _____

GENIUS MT

6-11/10-11 Gas, Tabletop Combi Steamer



GENIUS MT 6-11-3AG



GENIUS MT 10-11-3AG

Highlights

Eco Steam

- Energy-optimised and water-saving.

Power Steam

- More powerful for demanding food.

LED In-Door Lighting

- Lower power consumption, more environmentally friendly and longer service life.

Hybrid cleaning

- autoclean® PRO - water-saving, fewer chemicals in use, more flexibility.
- Liquid or Solid Tabs - use settings to set your preference.

9 inch display

- High definition, 9" Multi-Touch glass display with intuitive OS.

Customisable software

- Advanced customization easily configured to your process and menu.

Warranty

- 3 years parts, 2 years labor

GENIUS MT - combi steamer, gas, right-hinged - 6-11

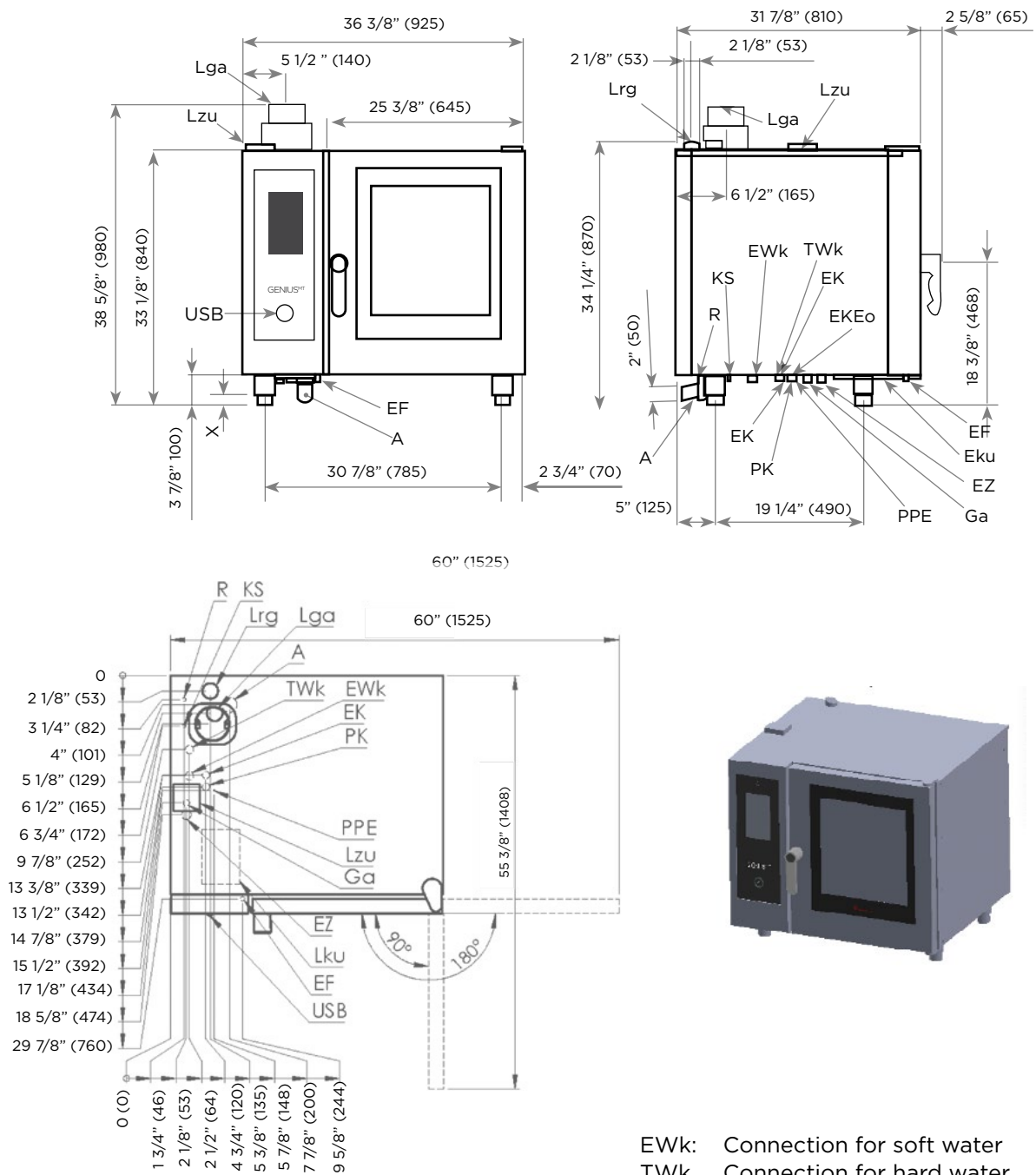

- Lzu Supply air opening
- Lrg Exhaust air pipe
- Lku Air intake for colling
- A Connection for waste water line
- X Feet, adjustable (=/- 3/8")

- EWk: Connection for soft water
- TWk Connection for hard water
- EZ Power supply
- EK Communications connection
- EF External sensor
- USB USB port
- PPE Connection for potential equalization
- PK Floating contact (optional)
- EZEo Power optimization
- EZKH Power supply
- R Connection for cleaner
- KS Connection for rinse



GENIUS MT – combi steamer, gas, right-hinged- 6-11, 10-11

Device Data	6-11	10-11
Material	1.4301	1.4301
Design Module	according to DIN 18866	according to DIN 18866
Protection Class	IPX5	IPX5
Device Dimensions	6-11	10-11
Hinge Left/Right (WXDXH) (in./mm)	36.4 x 31.9 x 33.1 / 925 x 810 x 840	36.4 x 31.9 x 44.1 / 925 x 810 x 1120
Weights	6-11	10-11
Electrical device (lbs./kg)	258/117	322/146
Gas device (lbs./kg)	280/127	344/156
Packaging (lbs./kg)	78/35	84/38
Capacity	6-11	10-11
Number of inserts	6 x GN 1/1	10 x GN 1/1
Cavity volume (cu.ft./l)	9.46/268	14.05/398
Insert spacing (in./mm)	2.64/67	2.64/67
Electrical connection for gas appliances	6-11	10-11
Gas connection capacity	12 kW	20 kW
Voltage 200-240 V 1 NAC/200-240 V 2 AC		
Power requirement (kW)	1.0	1.0
Fuse protection	1 x 16 A	1 x 16 A
Voltage 110-130 V 1 NAC/110-130 V 2 AC		
Power requirement (kW)	1.0	1.0
Fuse protection	1 x 16 A	1 x 15 A
Voltage 208-240 V 1 NAC/208-240 V 2 AC		
Power requirement (kW)	1.0	1.0
Fuse protection	1 x 15 A	1 x 15 A
Minimum cross section for connection(in ² /mm ²)	3 x .0023/1.5	3 x .0023/1.5

GENIUS MT - combi steamer, gas, right-hinged- 6-11, 10-11

Gas connection for gas units		6-11	10-11
Connected load (kW)		12	20
Gas connection thread (inches)		1/2	1/2
Gas consumption	Connection pressure	Heat Value	Maximum gas consumption at nominal thermal load
Gas type	[mbar] [kPa]	[MJ/m ³]	[m ³ h] / [kg/h]
Natural gas E (H)	18-25 1.8-2.5	34	1.3 2.1
Natural gas L	20-30 2.0-3.0	29	1.4 2.5
Propane	25-57 2.5-5.7	88	0.47 / 0.85 0.82 / 1.6
Butane	25-57 2.5-5.7	116	0.37 / 0.86 0.62 / 1.6
Burner capacity	Connection pressure	Heat Value	Minimal burner capacity
Gas Type	[mbar] [kPa]	[MJ/m ³]	[kW]
Natural gas E (H)	18-25 1.8-2.5	34	3.6 7.5
Natural gas L	20-30 2.0-3.0	29	3.6 7.5
Propane	25-57 2.5-5.7	88	4.5 7.7
Butane	25-57 2.5-5.7	116	4.5 7.7
Heat, noise emission		6-11	10-11
Heat, latent (MJ/h (kW))		4.3 (1.2)	7.2 (2.0)
Heat, sensitive (MJ/h (kW))		3.7 (1.0)	6.1 (1.7)
Noise emission dBA		<70	<70
Clearances			
Safety distance (in./mm)	Rear	2/50 (minimum)	
	Right	2/50 (minimum)	
	Left	2/50 (minimum)	
Minimum clearance	To combi, ovens, heating cabinets	2/50 (minimum)	
	Open flames, hot fat/oil, hot surfaces or similar	39.4/1,000 (minimum)	



GENIUS MT - combi steamer, gas, right-hinged- 6-11, 10-11

Water/Waste Water

Water Supply/dim	2 x 3/4"
Flow Pressure (PSI/bar/kPa)	29-87/2-6/200-600

Waste water connection

With autoclean® PRO	Permanent connection
Type	DN50 (min inside diameter: 1.81"/46mm) for permanent connection
Drain line gradient	minimum 3%

Soft water quality

General requirement	Drinking water	pH value	7.0 - 8.5
Total hardness		Cl - chlorine (ppm, mg/l)	max. 80
[°dH]	≤3	Cl ₂ - free chlorine (ppm, mg/l)	max 0.1
[ppm]	70-125	SO ₄ ²⁻ - sulphate (ppm, mg/l)	max 100
[°TH]	7-13	Fe - iron (ppm, mg/l)	max 0.1
[°e]	5-9	Temperature (°F/°C)	max 122/50

Hard water quality

General requirement	Drinking water	Electrical conductivity (µS/cm)	20 -90
Total hardness		Water Pressure (PSI/bar)	58/4 (29-87/2-6)
[°dH]	≤ 14	Max water flow w autoclean® PRO (gpm/l/min)	0.08/0.3
[ppm]	≤ 250	Power Steam (gpm/l/min)	0.49/1.85
[°TH]	≤ 25		
[°e]	≤ 18		

Hard Water

Hard water (w autoclean® PRO) (gpm/l/min)	1.8/6.8
---	---------

GENIUS MT – combi steamer, electric, right-hinged- 6-11, 10-11

STANDARD FEATURES

- High definition, 9" Multi-Touch glass display with intuitive operating system
- 12 operating modes: Steaming, Intensive steaming, Vario steaming, Convection, Combi-cooking, Low-temperature cooking, Delta-T cooking, Regenerating, Baking with steam injection, Holding, Proofing, Thawing
- Program list with 1000 programs, with 20 steps each
- Favorites list, mark during save, search
- Last20® recipe list
- Menu group marking during the saving process
- Temperature, adjustable between 86°F/30°C and 572°F/ 300 °C – accurate to the degree
- Core temperature, adjustable between 68°F/20 °C-212°F/100 °C – accurate to the degree
- Humidity range, adjustable between 0 – 100 %, accurate to the percentage point
- Fresh Steam system—Steam injection quantity, adjustable in 1 ml steps or seconds
- Fan speed in 5 increments, timed fan speeds, fan wheel auto-reverse
- ADC – Active dehumidification in 5 stages
- Eco Steam
- Power Steam
- Flashing light at the end of the cooking programme
- Adjustable volume of the signal tone
- Quick-action door closure
- Internal multi-point core temperature probe with 4 measuring points
- Frequency converter
- Automatic resting time in accordance with the steam injection quantity
- Time, adjustable up to 24 hours, including continuous operation
- Step overview
- Clean air filter alert

Cleaning:

- Fully automatic cleaning autoclean® PRO with liquid cleaner
- Hybrid - compatible with liquid or solid cleaner and rinse agents

- Drying phase freely selectable
- The drying phase can be interrupted during the cleaning operation
- Weekly Programming PRO for scheduling cleaning cycle
- Plug-in door seal for easy cleaning and maintenance

Settings & Service:

- Language setting in 25 languages
- Time and date setting
- Keyboard setting: 6 different versions
- Alphanumeric input
- Data and HACCP logging and display
- Automated cleaning and maintenance instructions, including blocking
- Automatic switching between standard time and daylight saving time

Programs and Media Manager:

- Image manager
- Favourites manager
- Program manager PRO
- Sound manager
- Water filter monitoring
- Setting and customisation options (Quick Modes/Direct Modes)

Start screen and start-up settings

- Standby image and time
- Version: light or dark
- Custom start screen
- Standby after cleaning and 15 min. inactivity

Programming

- Weekly programming PRO for cooking/baking programs and autoclean® PRO
- Multi-Cooking, Multi Baking PRO mixed loads
- Quick modes: cooking, baking, cleaning
- Individualization of the operating concept with password manager

OPTIONS

- Left-hinged door
- Safety door latch
- External core temperature probe
- External sous vide probe
- Special voltages
- Electric door lock for automatic door opening after end of cooking/baking programme and
- Electric door lock for automatic door opening after end of cleaning programme

ACCESSORIES

- Multi-Eco PRO Ventless Hood
- Stacking kits, base frames, heat shields, special hanging racks
- Tray and plate rack trolley
- Various trays, grills and containers
- Smoke Fit smoker unit

APPROVALS

