

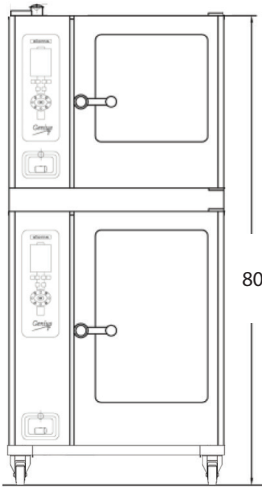

Project \_\_\_\_\_  
 Location \_\_\_\_\_  
 Item # \_\_\_\_\_  
 Quantity \_\_\_\_\_

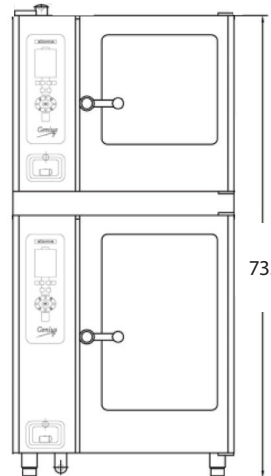

**Model 6-11/10-11 Electric with mobile stand**



**Model 6-11/10-11 Electric stationary**

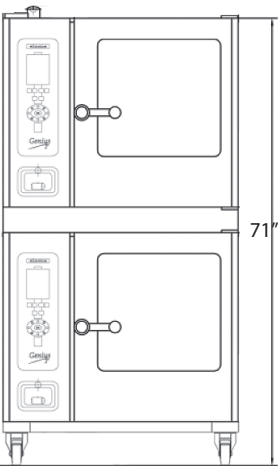

**Model 6-11/6-11 Electric with mobile stand**

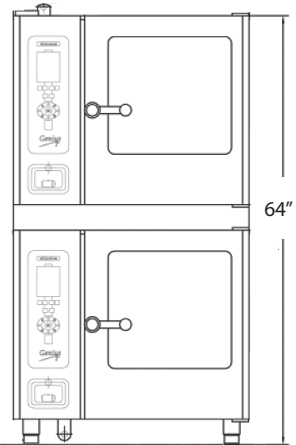

**Model 6-11/6-11 Electric stationary**

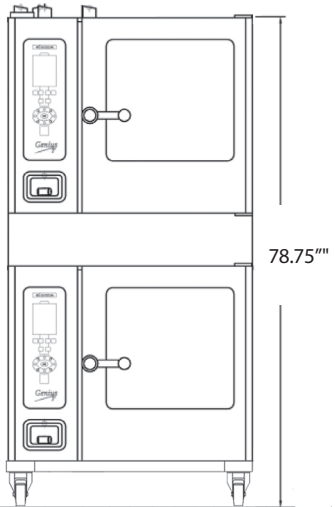

**Model 6-11/6-11 Gas with mobile stand**

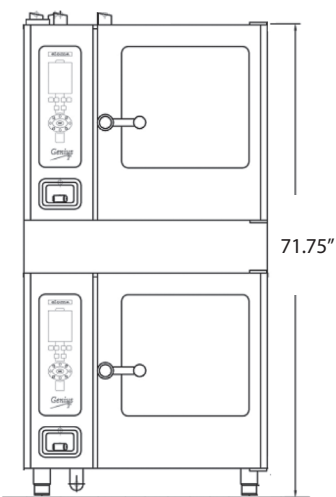

**Model 6-11/6-11 Gas stationary**

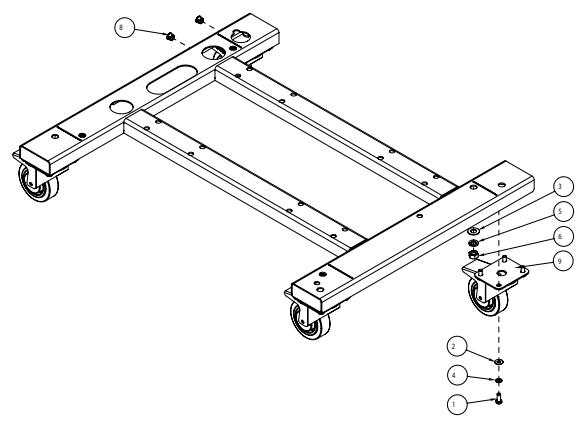

**Mobile Stand Construction**

Constructed to withstand temperature range from 86°F to 572°F and humidification from 0% to 100%. Chrome nickel steel CrNi 18, 10, BS 304 S15, AISI 304

Eloma North America  
 3765 Champion Blvd  
 Winston-Salem, NC 27105/USA  
 Toll Free 844-ELOMAUS (356-6287)  
 Fax 336/217-8807  
 sales@elomausa.com  
 www.elomausa.com