



VERSAs
DISPLAY

NDCOGS SERIES

NEUTRAL DISPLAY CASE

NDCOGS SERIES NEUTRAL DISPLAY CASE

- AVAILABLE IN 2 SIZES

NDCOGS-2721

NDCOGS-3821

- STAINLESS STEEL AND GLASS
- LED LIGHT AT TOP AND UNDER SHELF
- HINGED BACK DOORS
- INCLUDES PLASTIC TRAYS

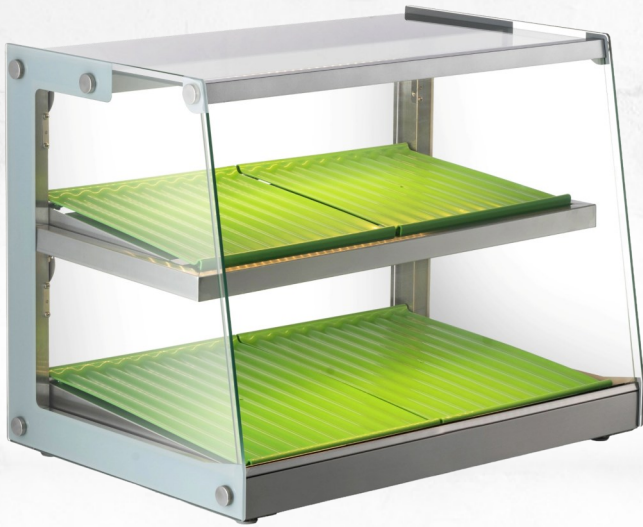

BACK VIEW



SIDE VIEW



FRONT VIEW



ADDITIONAL RESOURCES

DIMENSIONS

MODEL	PRODUCT DIMENSIONS					SHIPPING DIMENSIONS				
	WIDTH (A)	DEPTH (B)	HEIGHT (C)	WEIGHT LB/KG	CAPAC. (L/ CUFT)	WIDTH	DEPTH	HEIGHT	WEIGHT LB/KG	
NDCOGS-2721	INCH	26.8	17.9	20.3	57.3	100	28.5	20.2	23.2	83.7
	MM	683	457	516	26	3.5	725	515	590	38
NDCOGS-3821	INCH	38.8	17.9	20.3	76.0	150	40.5	20.2	23.2	110.2
	MM	988	457	516	34.5	5.2	1030	515	590	50

LINE DRAWINGS

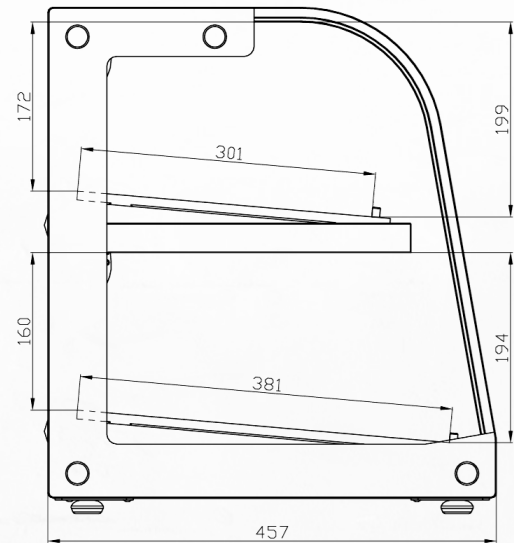
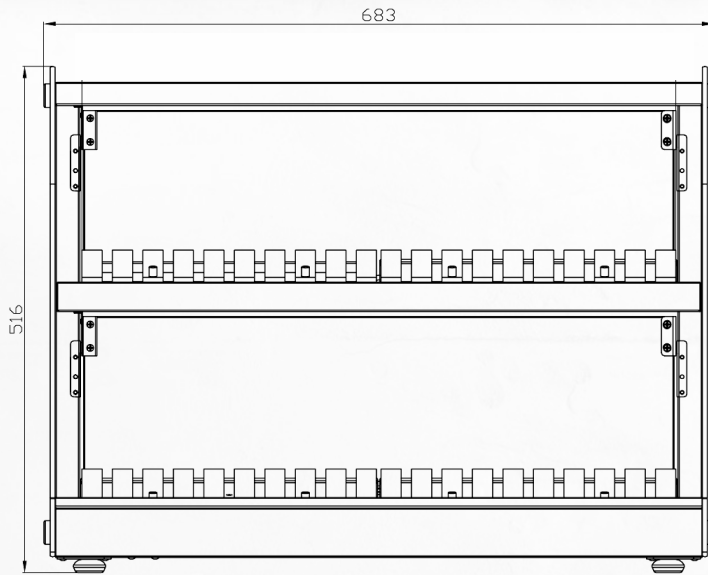

SPECIFICATION SUBJECT TO CHANGE WITHOUT NOTICE



EFI Sales Ltd.
 Toronto Office & DC
 515 Hanlon Creek Blvd.
 Guelph, ON, N1C 0A1

EFI Sales Ltd.
 Vancouver Office & DC
 26895 Gloucester Way
 Langley, BC, V4W 3Y3

(888) 565-9020 Toll Free
 (519) 822-1895 Toronto
 (604) 607-8850 Vancouver