

Project name:	Date:
Location:	AIA #:
Manufacturer representative:	Item # / Quantity:

DRYAGER™ UX 1500 PRO S

For up to 220 lbs of product*



Professional refrigerated single section dry aging cabinet for commercial production of **dry-aged meats, charcuterie, fish** as well as for the production and storage of cheese and wine in foodservice, hospitality, retail and food processing industries. Equipped with SmartAging™ Technology for easy selection of product-specific dry-aging and curing programs. **Self-contained R600a refrigeration** (115V – 2A) maintains perfect microclimate with electronic temperature (32–86 °F) and humidity (40–90%) control for minimal product loss **without the requirement for water connection or drain**. Unique UX Airreg™ **UV sterilization system** maintains internal air quality and flow without UV exposure of the product. Stainless steel, black or custom color exterior and antibacterial polystyrene interior with integral rack slides and stainless steel back cover. Cabinet designed for **built-in or free-standing application** for single section or multi-unit integration. The standard warranty is six years compressor, three years parts and labor.



Nº1 BRAND WORLDWIDE** Quality from Germany



The Dry Aging Bible: included with every DRYAGER™ PRO S Cabinet

Conformity

UL 60335-1: 2016
 UL 60335-2-89: 2017
 CAN/CSA-C22.2 No. 60335-1:16
 CAN/CSA-C22.2 No. 60335-2-89:17
 NSF/ANSI 7: 2016



Standard features

Dry aging and curing programs

- **SmartAging™ Technology** – Enables dry aging with the help of product-specific aging programs, including various flavor intensity profiles as referenced in the Dry Aging Bible (included with cabinet)
- Automatic temperature, humidity and airflow settings carried out by the SmartAging™ processor
- Manual operation also possible without utilizing SmartAging™ Technology

Temperature & Humidity

- Humicontrol™ – steady humidity electronically controlled from **40% to 90%** without the requirement for water connection or drain
- Electronically controlled temperature from **32°F to 86°F**
- Superior aging with minimal weight loss
- Automatic defrost and automatic condensation evaporation

Hygiene

- UVC sterilization system UX Airreg™ – optimal airflow & air quality without UV exposure of the product
- Antibacterial interior with molded slides and covered corners

Visual design

- Stainless steel exterior and door frame
- UX-LED lighting – dimmable side and ceiling interior lighting for perfect display of products
- Maximum visual appeal & merchandising potential

Safety

- UV protection through tinted double pane glass door
- Visual & audible alarm
- Lockable door and snap-in magnetic gasket

Modularity

- Cabinet designed for free-standing or built-in application for single section or multiple units
- Door hinges reversible

Included accessories: XL accessory package Pro S

- 1 x Book “The Dry Aging Bible” (DU2041) – dry aging knowledge and recipes on more than 300 pages
- 4 x Full shelf (DUS020) – stainless steel, max. load/shelf 88 lbs
- 1 x Double hanger (DU0010) – stainless steel, max. load 176 lbs
- 1 x SALTAIR tray (DU0070) – stainless steel
- 4 x Swivel hook – stainless steel, max. load/hook 220 lbs

Standard warranty

- Compressor: 6 years, parts & labor: 3 years

Technical specifications

Internal capacity/net	17.0/15.3 cu. ft. (482/432 liters)	LED interior lighting dimmable	Yes
Maximum load	220 lbs (100 kg)	External housing finish	Stainless Steel / Black / Custom Colors
Internal Dimensions HxWxD	53.98 x 22.76 x 23.11 in	Door material	Stainless Steel / Black / Custom Colors & metallic tinted glass (UV protect)
External Dimensions HxWxD	64.96 x 27.56 x 29.21 in	Door reversible & lockable	Yes
Temperature range	32°F to 86°F (0 °C to 30 °C)	Magnetic door seal, exchangeable	Yes
Humicontrol™	40% to 90%	Door handle	Robust
Connection rating	115 V / 2A / 60 Hz	Alarm	Visual & acoustic
NEMA plug configuration	5–15 P	Installation	Integration & free standing
Average energy consumption	~1.6 kWh / 24h	Ambient temperature	50°F to 86°F (10 °C to 30 °C)
UVC sterilisation system	Yes	Refrigerant	R600a
SmartAging™ Technology	Yes	Empty weight	194 lbs
Water and drain connection required	No	Shipping weight (on pallet)	285 lbs
Automatic defrost and condensation evaporation	Yes	Shipping dimensions HxWxD (on pallet)	83.00 x 42.00 x 42.00 in

* Maintain at least 2 in clearance between the cabinet walls, door, and food products for proper airflow and performance
 ** For professional dry aging solutions

DRYAGER™ UX 1500 PRO S

For up to 220 lbs

Application: Dry Aging of meat

① UX 1500 PRO S on podium (DU0080) for perfect presentation at the eye level



Beef on shelves



Two saddles of beef hanging



Saddles of pork and beef hanging



Beef on shelves and pork hanging below

SmartAging™ makes it possible: One Cabinet – various applications



Charcuterie production: Sausage and ham | Dry Aging of meat*



Dry Aging of fish and seafood | Dry Aging of meat*



Dry Aging of poultry and meat | storing and production of cheese*



Tempering champagne and wine | production and storing of cheese*
NEW: Wooden slide-in shelves available

*Shelves in pictures differ from UX 1500 PRO S shelves.

DRYAGER™ UX 1500 PRO S

For up to 220 lbs

Housing: Color options



All RAL and Pantone colors available

UX 1500 PRO S Standard

UX 1500 PRO S Black

UX 1500 PRO S Custom color

Item no.	UX1500PS	UX1500PSP	UX1500PSC
Housing color	Stainless steel	Black, powder-coated	Custom color premium finish glossy or matte
Door Frame and Handle color	Stainless steel	Black, powder-coated	Custom color premium finish glossy or matte

Custom color solutions available on request: Separate painting of door, housing, handle upon request



*Shelves in pictures differ from UX 1550 PRO S shelves.

DRYAGER™ UX 1500 PRO S

For up to 220lbs

Drawings

Front view

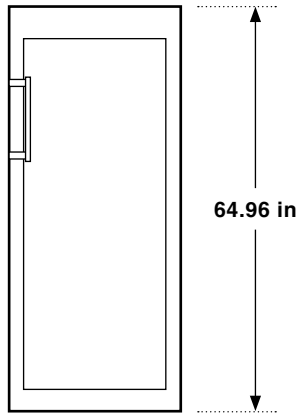

Front view with podium

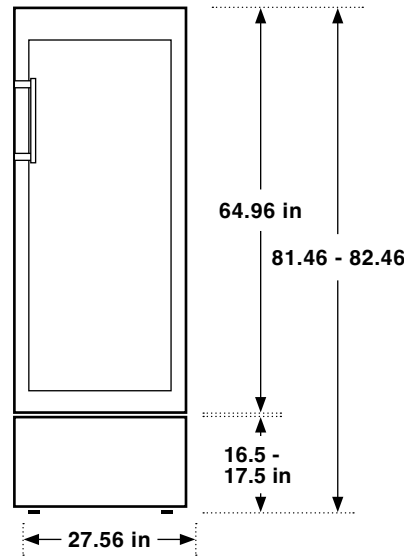

Top view

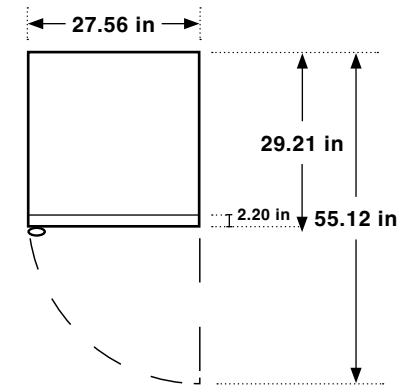

Integration drawing

Single unit installation

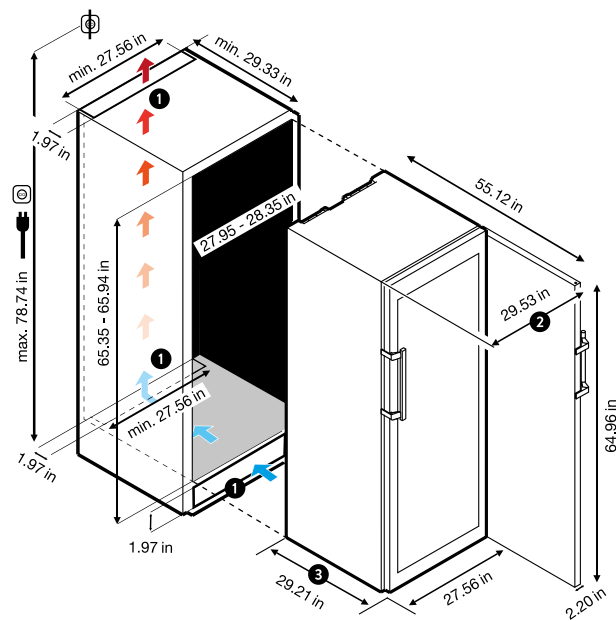

Side by Side integration

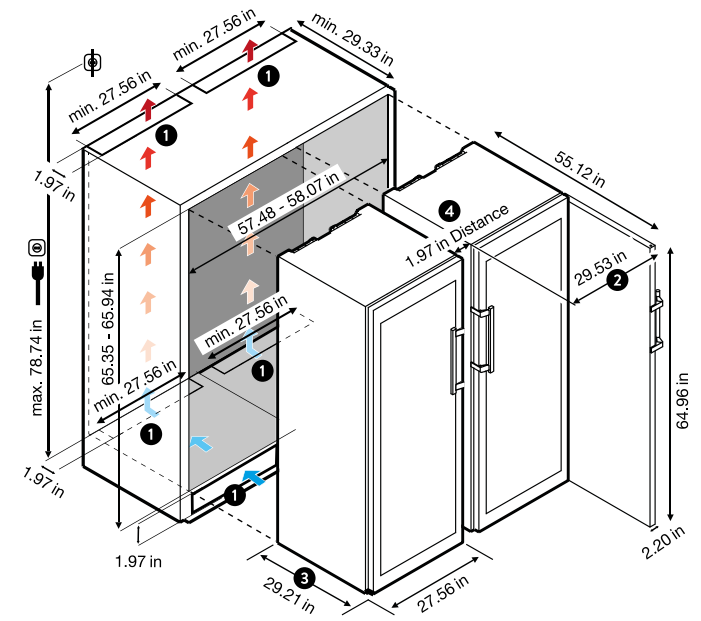

- It is absolutely essential to have good air circulation around the unit. The width of the ventilation shafts needs to be at least the width of the appliance (see ❶). The minimum required depth/height of the shafts is 1.97 in. Also ensure that the back of the appliance is positioned at a distance of at least 1.97 in from the wall.

- Overall dimension with opened door (see ❷): 29.53 in.

- Overall dimension body + door (protruding) (see ❸): 29.21 in.

- Covering of distance (see ❹) possible by Stainless Steel Cover, available as an accessory at: shop.dry-ager.com.

DRYAGER™ UX 1500 PRO S

For up to 220 lbs

Free XL Accessory Package Pro S Included with every DRYAGER™ PRO S Cabinet



Optional Accessories for UX 1500 PRO S

Single Accessories

- DU0005 Stainless Steel Cover**
for side-by-side integration installation of two UX 1500 PRO S units at a distance of 1.97 in.
- DU0010 Double Hanger**
stainless steel, for hanging up to 4 saddles of meat, total load capacity: 176 lbs, hooks not included
- DUS015 Half Shelf**
stainless steel, for loading over half depth of unit, insertable at many different heights (integral rack slides), load capacity per shelf: 44 lbs
- DUS020 Full Shelf**
stainless steel, for loading over full depth of unit, insertable at many different heights (integral rack slides), load capacity per shelf: 88 lbs
- DUS022 Charcuterie Shelf**
special designed stainless steel shelf for hanging of sausages, salami and ham over half depth of unit, insertable at many different heights (integral rack slides), load capacity per shelf: 44 lbs
- DU0055 SALTAIR Salt-Block Set**
4 pieces of natural crystal salt for optimal support of the humidity regulation, use with DRYAGER™ stainless steel tray (DU0070)
- DU0070 SALTAIR Tray**
high quality stainless steel tray to hold one DRYAGER™ salt-block set (DU0055, not included)
- DU0080 Podium**
perfect presentation of free-standing UX 1500 PRO S unit at the eye level, made of sturdy metal, metallic black powder-coating, height adjustable (16.5-17.5 in), including DRYAGER™ logo, optional with wheels (DU0082)
- DU0180 Caster Set**
4 x casters (2 casters with brakes) including mounting material, height 5.12 in
- DU0190 S-Hooks Set**
10 hooks from high quality stainless steel for usage with DRYAGER™ hangers, size 6.3 x 0.3 in, load capacity per hook: 220 lbs
- DU0195 Swivel Hooks Set**
10 swivel hooks from high quality stainless steel, for usage with DRYAGER™ hangers, size 7.1 x 0.3 in, load capacity per hook: 220 lbs

Packages

- DU0130 DRYAGER™ Special Cleaner Package**
Set of two NSF listed cleaners to remove fat, oil, protein residues etc., 16.9 oz (500 ml) spray bottle
- DU0140 XL Meat Label Package**
40 stainless steel skewers with DRYAGER™ designed labels made of reusable plastic
- DU1555 Taste & Operation Package**
1 x SALTAIR Salt-Block Set (DU0055), 1 x XL Meat Label package (DU0140), 1 x DRYAGER™ Special Cleaner package (DU0130)
- DU1560 Charcuterie & Flexibility Package**
3 x Charcuterie Shelf (DUS022), 3 x Half Shelf (DUS015)
- DU0129 Wooden Shelf Package – beech wood** **NEW**
4 x full shelf, 1 x half shelf made from beech wood, ideal for the presentation of packed food and beverages such as wine

Package also available in stamed beech wood (DU1229)



Books

- DU2041 The Dry Aging Bible** **NEW**
The Dry Aging Bible with more than 330 pages is a complete resource offering 89 Dry Aging & cooking recipes, endless inspiration and expert insights.

Also available in Spanish language (DU2042).

Maintenance

- DU0115 UVC Bulb Replacement Kit**
replacement bulb for annual maintenance of UVC sterilization system
- DUW150 Warranty Extension**
Compressor: 8 years, parts & labor: 4 years

DRYAGER™ UX 1500 PRO S

For up to 220 lbs

The Dry Aging Bible – The standard reference on Dry Aging and SmartAging™ included with every DRYAGER™ PRO S Cabinet.

- 336 Pages
- 89 Dry Aging & cooking recipes
- Inspiration & expertise

Our Awards:



Best Book 2022 in the category „Meat & Poultry“



Category E12 Meat Best Book in the world in 2023

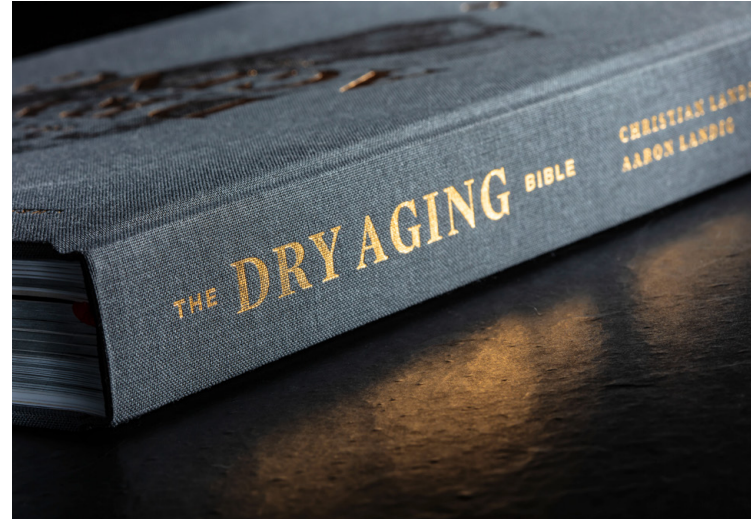

DRY AGER reserves the right to change specifications without notice. This document may be subject to typesetting and printing errors.