

PZ400/PZ420

"Pellet Fired Pizza Oven

COOKSHACK



Hand-crafted, artisan pizza has never been easier or tasted so good as with the PZ400 and PZ420, fast, consistent, and versatile!



Fast

A handcrafted pizza cooked over real wood flames is ready in just 3 minutes.

Easy

No need to turn the pizza or manage a fire with this pizza oven's advanced controls. The technology you already love has been upgraded to deliver brick oven flavor with the press of a button.

Consistent

Temperature variances are almost non-existent with the same technology we use in our pellet grills.

Versatile

The temperature range of 250°F - 900°F means this oven is not limited to pizza alone. Give authentic flavor to calzones, quesadillas, stromboli, desserts, and much more.

Convenient

One of the primary benefits of the Cookshack Pizza Oven is its size. Most wood fired pizza ovens are bulky or need to be left outside. With the PZ400 and PZ420, there is no need to remodel an entire kitchen to add gourmet pizza since it can be installed under a standard commercial hood.

PZ400/PZ420

“Pellet Fired Pizza Oven

COOKSHACK

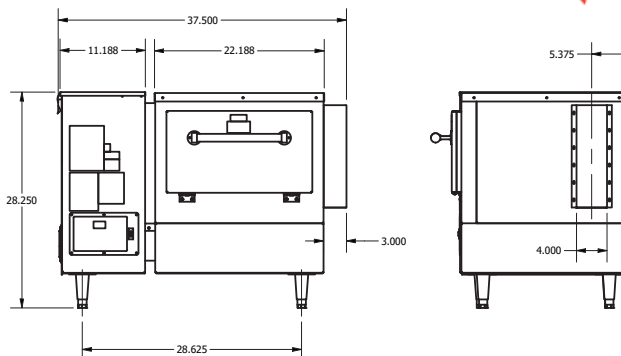
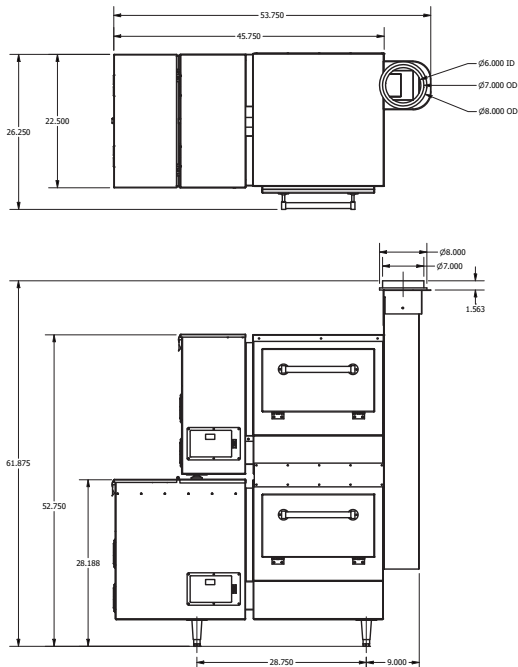

Product	PZ420	PZ400
Outside Dimensions	54"W x 27.75"H x 26.25"D (33.375" w/door open)	37.5"W x 27.75"H x 26.25"D (33.375" w/door open)
Front Loading Hopper	25 lb. Capacity	
Approximate Fuel Consumption	Recommended temperature of 700°F: 2.25 lbs. per hour. High (900°F): 3.1 lbs. per hour	
Cooking Area	16" x 16" Pizza Stone	
Pre-Heat Time	Approximately 20 minutes to reach 700°F, 1 hour for the pizza stone to sync to 700°F	
Pizza Cooking Time	Approximately 3 minutes for 1 large pizza at 700°F (Times will vary based on oven temperature)	
Shipping Weight	650 lbs.	375 lbs.
Standard Equipment	4 bags of pellets (20 lb. bags), pizza stone, heat deflector, operator's manual	
Capacity	1 large pizza up to 16" diameter	
Electrical	120v, 5 amps; cord length is approximately 54" (± 6")	
Construction	Double walled construction surrounding 850°F Spin-Glas® Insulation	
Warranty	All Cookshack products are backed by a 2 year limited warranty including 90 days full parts and labor.	



Cookshack, Inc.
2405 Sykes Blvd | Ponca City | OK | 74601-1111 | United States
580-765-3669 | 800-423-0698 | Fax: 580-765-2223
sales@cookshack.com

Revised February 2025