



193
SP G

The ultimate gravity fed counter top model for high volume production with heat treatment.



Performance and Quality The Carpigiani reputation for the smoothest, creamiest soft serve in the market is proven with this powerful, customizable model for two flavors and twist flavor. Hard-O-Tronic consistency control technology Exclusive patented system that regulates refrigeration by measuring product viscosity to maintain consistent quality control. The Optional Star Door allows you to use different nozzles to create unique shapes and monoportion products.



Convenience Hopper agitator prevents mixture separation and maintains consistent refrigerated temperature. Audible Signal alerts when refill is needed. Mix is fed from the rear of cylinder eliminating need to prime and allowing more controllable overrun.



Savings Lowest power consumption and the least number of components to clean. Unique cylinder construction delivers better results using less electricity.



Safety TEOREMA guarantees facilitated assistance by providing on-line monitoring and diagnosis on a tablet, phone or PC wherever you are.



Hygiene Standby mode maintains safe product temperatures in the freezing cylinder and mix hopper utilizing minimal energy during long no-use periods. Our automatic heat treatment system makes it possible to set the automatic heat treatment at a maximum interval of 42 days. *Always check with your Local Health inspector as cleaning requirements may vary.



Carpi Care kit



Carpi Clean kit*



*request the kits from your distributor to maintain your machine hygienically clean.

carpigiani.com/us

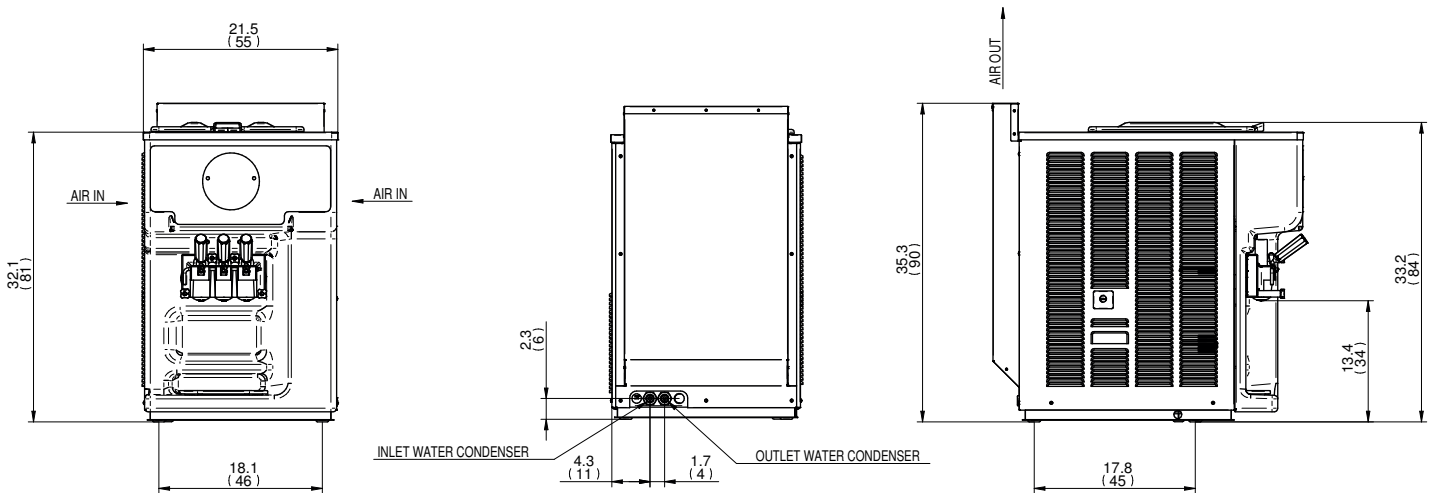

	WATER		AIR	
	lbs.	kgs.	lbs.	kgs.
Weights				
Net	418	190	440	200
Crated	511	232	507	230
	cu. ft.	cu. m.	cu. ft.	cu. m.
Volume	30.37	0.86	29.31	0.83
	in.	cm.	in.	cm.
Dimensions				
Width	21.5	55	21.5	55
Depth	34.4	88	34.4	88
Height	35.3	90	35.3	90
	Electrical	Maximum Fuse Size	Minimum Circuit Ampacity	Poles (P) Wires (W)
	208-230/60/1 A	50A	40A	1P, 1W
	208-230/60/3 W / A	30A	30A	3P, 3W

Specifications

Electrical

A dedicated electrical connection is required. Manufactured to be permanently connected. See the Electrical chart for the proper electrical requirements. Consult your local Carpigiani distributor for cord & receptacle specifications as local codes allow.

Beater Motor

1,2 HP + 1,2 HP

Refrigeration System

R449A

Water Cooled

Water inlets and drain connections in the rear 1/2" MPT

Air Cooled *

Minimum clearance: 3" (8 cm) on both side panels and 0" (0 cm) from the rear panel for proper air circulation.

Hopper Capacity

Individual hopper capacity: 19 quarts (18 liters)
Total hopper capacity: 38 quarts (36 liters)

All specifications mentioned must be considered approximate; Carpigiani reserves the right to modify, without notice, all parts deemed necessary. This unit may be manufactured in other electrical characteristics and may have additional regulatory agency approvals, please consult the local Carpigiani Distributor. Check name plate for exact electrical data. * Room temperature 68 °F (20 °C).

Bidding Specs

Electrical Volt _____ Hz _____ Ph _____ Neutral Yes No Cooling Air Water

Options _____



738 Gallimore Dairy Road, Suite 113
High Point, NC - 27265
Toll free (800) 648 4389

Dealer



an Ali Group Company



the spirit of excellence