

Project _____
Item _____
Quantity _____
FCSI Section _____
Approval _____
Date _____



Broaster® Perfect Hold™ Cabinet



Standard Features

- *Newly redesigned for even greater durability and performance*—strong, welded construction exterior includes stainless steel finish on all sides. Heavyduty swivel casters with wheel locks make unit stationary or easily movable.
- *Holds cooked food for peak times without compromising quality*—help yourself by cooking ahead to beat the inevitable lunch or dinner rush.
- *Spacious interior*—holds up to 7 pans of cooked Genuine Broaster Chicken® and other fine foods.
- *Quick temperature recovery*—high air flow rate enables cabinet to rapidly recover temperature after opening and closing door.
- *Regulated air temperature, easily adjustable humidity*—thermostatically controlled heating maintains consistent temperature of interior food environment while adjustable door louvers allow you to balance humidity level without drying foods out for optimal product crispness and freshly prepared taste.
- This easy to maneuver Portable Holding Cabinet is perfect for serving counters, buffet lines, drive-up windows, point-of-service or presentation areas.
- This holding cabinet is capable of holding all types of hot foods at optimum serving temperatures.
- Thermostatically-controlled heat and humidity allow for the preparation of food in advance of peak periods and hold it for hours.
- The Perfect Hold Holding Cabinet can be stacked one on top of the other providing two separate humidified temperature zones. Ideal for schools, hospitals, concessions and cafeterias where backup food storage is needed.



Broaster® Perfect Hold™ Cabinet

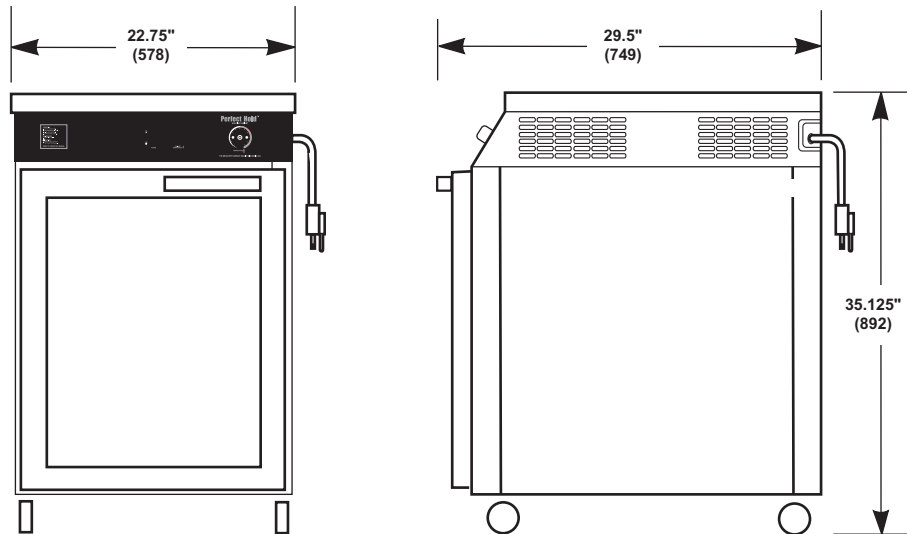

Dimensions

Overall Dimensions			Net/Ship Weight	Overall Volume
W	D	H		
22.75"	29.5"	35.125"	155/168 lbs.	13.64 cu.ft.
(578 mm)	(749 mm)	(892 mm)		

Energy Requirements

120V, 1 Ph, 60 Hz, 12 Amps, 1447 Watts
 (6' cord & NEMA 5-15P plug standard (NEMA 5-20P plug furnished for Canada))

Additional Features

- Large, insulated, aluminum-framed, stainless steel door can be hinged for either left or right access.
- Adjustable stainless steel angle slides accommodate up to seven 12" x 20" (305 x 508) food pans or 18" x 26" (457 x 660) sheet pans on 3" (76) centers.
- Thermostatically controlled heat with digital temperature readout.
- Power cord recessed within protective cut-out.

Accessories & Options Available

- Stacking Kit
- Dump Top Accessory



Note: This unit has earned the Energy Star®.



Products that earn the ENERGY STAR® prevent greenhouse gas emissions by meeting strict energy efficient guidelines set by the U.S. Environmental Protection Agency and the U.S. Department of Energy.