

BROASTER
EQUIPMENT

Broaster® E-Series Pressure Fryer - 24G

Featured Innovations



- **Highest Energy Efficiency in Pressure Fryer Category** – gas-fueled E-Series 24G boasts the highest-level energy efficiency burner systems (75,000 BTU/hr), offering 35% less gas usage when compared to the legacy Broaster 2400 model. Ready for Energy Star application once EPA has established standards for pressure fryers.
- **Auto-Lift Feature** – reduces need to lift heavy basket providing a safer and operationally friendly work environment, making it easier to handle a large quantity of chicken.
- **Shelving & Rack System** – 4 shelves provide even cooking, uniform product appearance, and safer operator ergonomics. Sheet pan holder provides operator workspace to transfer shelves.
- **One-touch Cook Cycle** – cook cycle starts automatically with lid closure, no need to hit “Start.”
- **Automatic Controlled Pressure Release** – end of cook cycle automatically triggers release of pressure within the cooking well, can be programmed for soft, controlled release.
- **More Production Capacity** – the largest 8 piece capacity amongst pressure fryers. Elimination of a long manual oil filtration paired with an enhanced burner system means more efficient heat recovery and more fry time.
- **Automatic Oil Filtration Between Cook Cycles** – unit automatically begins a quick filtration cycle after each cook cycle. Duration of filter cycle can be adjusted to operator preference in SmartTouch™ Controls. Expect weeks of oil life compared to days of oil life in traditional units.
- **Smartdrain Technology** – detects obstructions during draining and recognizes if crumb buildup is inhibiting the flow of oil.
- **On Board Oil Replenishment** – ability to top fryer oil off easily and automatically based on operator need.
- **Bulk Oil Handling** – easily connects to bulk oil input and discharge systems to eliminate employee handling of oil.
- **Advanced Microprocessor Controller** – easy-to-use, touch screen interface reduces training time for new employees. Bilingual interface included.



TESTED TO ANSI Z83.11 – CSA 1.8 – 2016
TESTED TO ANSI / NSF 4

Safety Features

Triple-redundant safety system is featured consisting of a chrome plated relief valve, a smooth, articulating stainless steel splash guard and a single action patented cam lock cover system.

To ensure operator convenience and safety, unit features a pressure activated cover-locking mechanism and the SmartTouch Controller which integrates an automatic pressure regulator valve, exhaust valve, and drain valve interlock.

Large capacity filter pan on casters with splash protection for ease of moving and cleaning

Standard setup includes on-board oil replenishment for easy oil top off. Reservoir slides and tilts out for hands-free oil top off.

Available bulk oil handling connections eliminate the need for employees to handle heavy oil containers and dispose of hot oil.

Front panel door swings open to allow access to unit, keeping panel elevated and out of the way for service.

A maximum of two screws allows access to any part of the machine, making it quick and easy to service.

Broaster® E-Series Pressure Fryer - 24G

FRONT VIEW

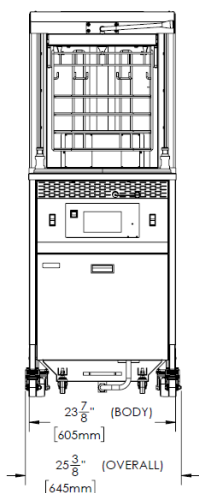

SIDE VIEW

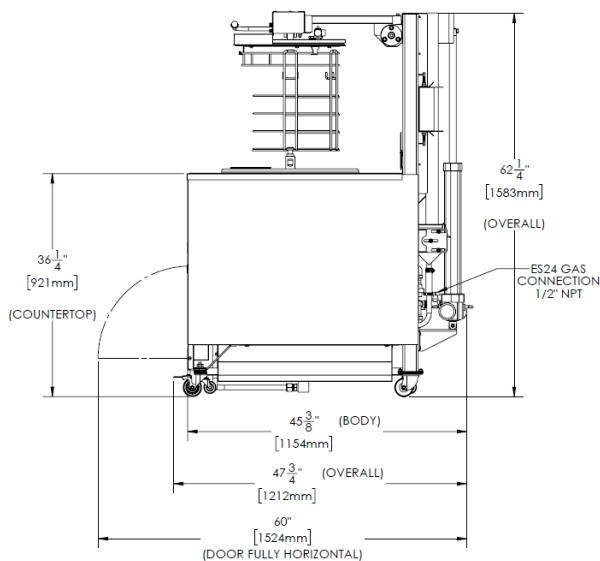

TOP VIEW

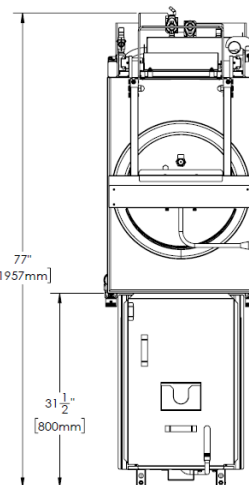

RACK & SHELVES

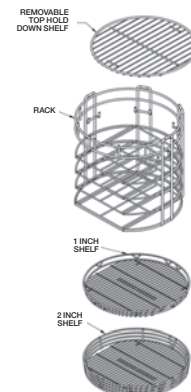

Dimensions

Model	Fresh Chicken Capacity	Cooking Oil Capacity	Operating Pressure	Overall Dimensions			Counter Height	Net/Ship Weight
				W	D	H		
ES24G	26 lbs. (64 pcs/8 hds)	70 lbs.	12 - 14 P.S.I.	25.375"	48"	62.5"	36.25" (922 mm)	600/650 lbs.
				(645 mm)	(1220 mm)	(1586 mm)		

Additional Features

Specifically designed for high volume production, cooks up to 64 pieces of fresh bone-in chicken per load in as little as 11-12 minutes when using 4 round, 2 head shelves.

Two options for shelving configurations to match your back-of-house process; individual shelves available in 1 inch or 2 inch heights.

Unique Auto Comp feature automatically adjusts cooking time to accommodate for varying sizes and temperatures of loads.

Perfect for all your fried chicken cooking needs, including hand breaded tenders and fillets.

Primary construction is of stainless steel built on black powdercoated steel frame with front and rear casters for mobility and ease of cleaning.

Proven round cooking well design engineered for more uniform heat distribution, durability and efficiency; no cold spots or corners. Large capacity provides more room for product, minimizes sticking and produces delicious, superior quality food.

Fully welded cooking well is made from durable 300 series stainless steel.

Specifications subject to change without notice.

Energy Requirements

75,000 BTU/hr
1 phase, 120 volt, 60 hz, 15 amp service
Attached 6 ft. cord with plug
Requires NEMA 5-15 plug type for 120v



Mainfold Pressure:

Natural Gas: 3.5 in-wc
LP Gas: 10 in-wc

Ready for Energy Star application once the EPA has established standards for pressure fryers.

Accessories and Options

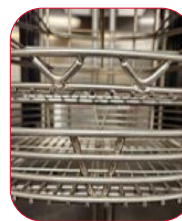

Unit Ships Standard With:

One rack, a complete set of four shelves and two handles

Choose Between:

1" tall sides or 2" tall sides

Both are round and hold 2 head per shelf