

Blueair by
BLUENIX

MODEL BLUN-120A

**NUGGET ICE
UNDERCOUNTER**

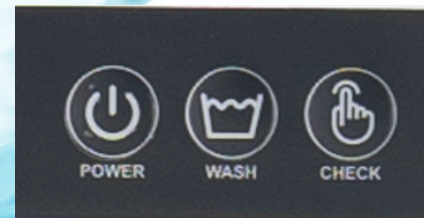
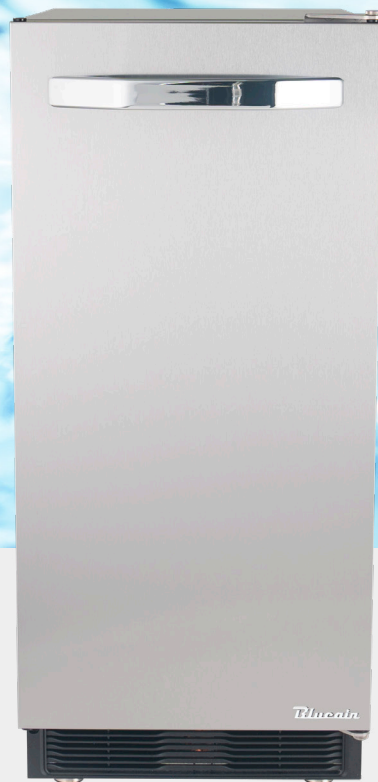

**Produces up to
126 lbs of ice daily**

Unit produces individual nugget ice



**Durable stainless steel
cabinet and evaporator**



Hydrocarbon refrigerants (R-290)

While safer for the environment our
Hydrocarbon machine products are also
more energy efficient.



Easy cleaning system

No special tools necessary to navigate our
"one touch" cleaning feature.



Valid in the Continental United States

Service

- Digital self diagnostic system
- Panels easily removed and all components accessible for service.
- Allow 6" (15cm) clearance at rear, sides, and top for proper air circulation and ease of maintenance/service.

Plumbing

- 3/8" water supply line, nominal ID (interior dimension).
- Drain Line: Minimum 3/4" ID hard pipe, PVC, or equivalent
- Maximum time for dispensing ice can be adjusted

Accessories

- IMDP-120(Pump Kit)
pulled up to 23 feet to drain and can be located without a gravity drain.
Shipping Size: 13"*9"*10" (330mm*235mm*255mm)

BLUN-120A

Front view

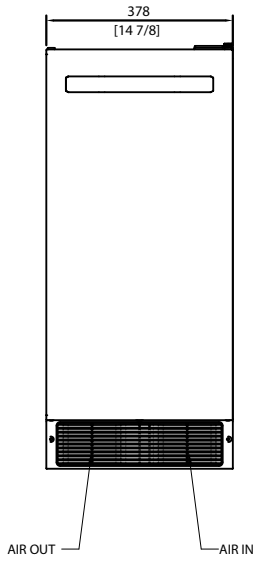

Side view

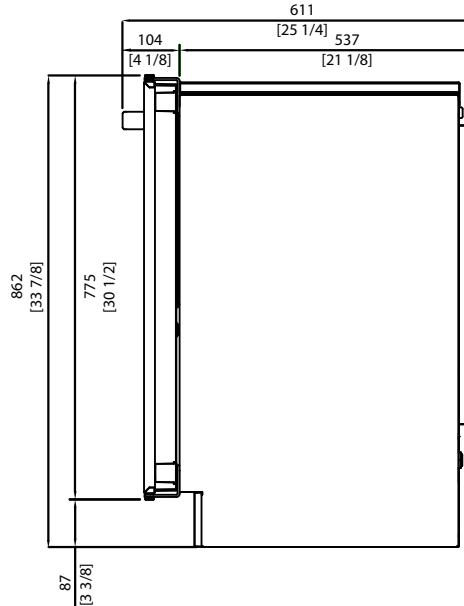

Cube Dimensions

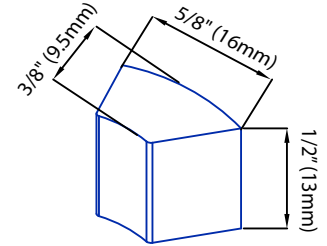

Ice hardness factor : 91.4%

Approximate Size in inches, image not to scale.

Back view

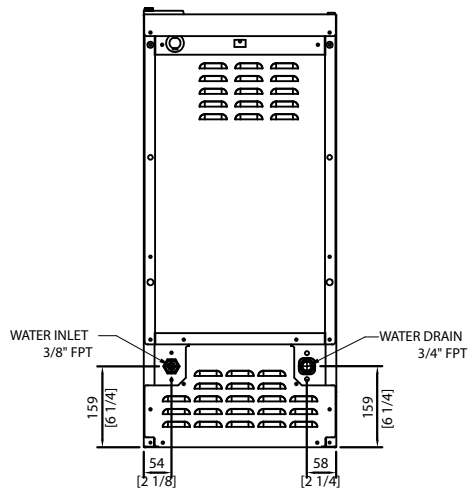

Top view

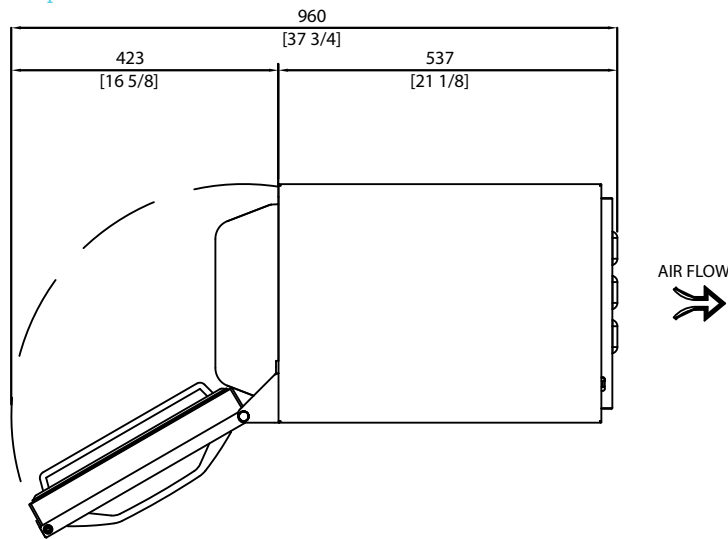

Ice Production

Air / Water Temp
Lbs. per 24 hrs

70°/50°F	100°/90°F
126lbs	85lbs

Built-in Ice Storage

22lbs

Rated in accordance with AHRI standard 821

Air 90°F / Water 70°F

Electric consumption
per 100 lbs.

6.8 w

Water consumption
per 100lbs

12 gal

Condenser Air-Cooled

Min. Circuit Ampacity

4

Max. Fuse or Breaker Size

15

Voltage V/HZ/PH

115V/60/1

Shipping Weight

139 lbs / 63 kg

Connection

9.8 ft long (3m) flexible three wire cords with molded plug

BLUE AIR has right to change specifications without further notice.

Operating Limits

Ambient Temp Range: 45 - 100° F

Water Temp Range: 45 - 90° F

Water Pressure: 10 - 100 PSIG

Voltage Range: 100 - 130V



This product may expose you to chemicals including Diisononyl Phthalate (DINP), which is known to the State of California to cause cancer. For more information go to www.P65Warnings.ca.gov.



blueairfse.com



orders@blueairfse.com



223 W. Rosecrans Ave., CA 90248
T: 310-808-0102

9 W. Shelton Terrace #A, Hillside, NJ 07205
T: 470-625-0182

7025 Amwiler industrial Drive, Suite A, Atlanta GA
T: 908-688-0970