



223 W Rosecrans Ave., Gardena, CA 90248  
T. 310-808-0102 www.blueairfse.com

Project:	
Location:	
Item #:	
Model #:	Qty:
AIA #:	SIS #:
CSI Section 11400	

## Back Bar Cooler - Narrow Depth / Sliding Door

Model  
**BLNBB-60BG-SL-HC**

Model

## BLNBB-60BG-SL-HC



### Cabinet Construction

- Stainless steel top with black powder-coated steel exterior and stainless steel interior
- High-density, foamed-in-place polyurethane insulation – environmentally friendly
- Two (2) adjustable shelves per section
- Interior height allows stacking of three “tall boy” beers
- Four (4) 4” diameter swivel casters with front brakes standard

### Refrigeration

- Front-breathing, side-mounted compressor for efficient operation in tight spaces and easy service access
- Forced-air cooling system maintains consistent temperature throughout the cabinet for reliable performance
- Automatic defrost system minimizes maintenance and ensures stable operation

### Hydrocarbon refrigerants (R-290)

- Hydrocarbon refrigerant (R-290) increases energy efficiency and does not deplete the ozone layer.

### Doors

- Sliding doors for smooth, space-saving operation in tight service areas
- Insulated tempered glass enhances product visibility while maintaining consistent temperatures

### Design & Features

- LED interior lighting for enhanced product visibility
- Digital temperature control with real-time monitoring
- Optimized airflow for consistent cooling performance
- Maintains cabinet temperatures of 34°F to 38°F for optimal beverage preservation



Model	Doors	Shelves	Capacity (Cu.ft.)	HP	AMPS	W x D x H <sup>†</sup> (inches)	Crated Weight (lbs.)
BLNBB-60BG-SL-HC	2	4	15.6	1/3	3.0	61 <sup>1</sup> / <sub>8</sub> x 24 <sup>3</sup> / <sub>8</sub> x 36 <sup>1</sup> / <sub>4</sub>	311

# Back Bar Cooler - Narrow Depth / Sliding Door

## PLAN VIEW

(Unit: inches)

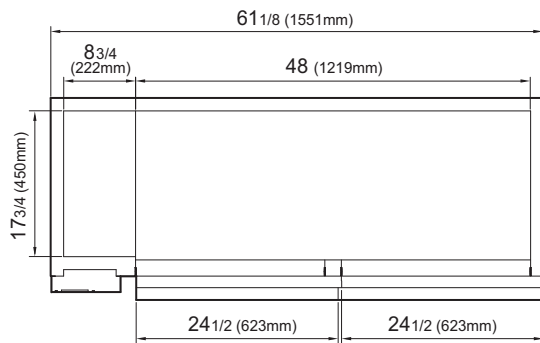

TOP VIEW

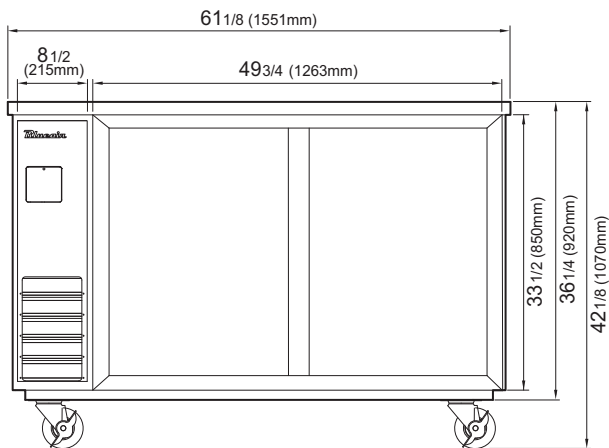

FRONT VIEW

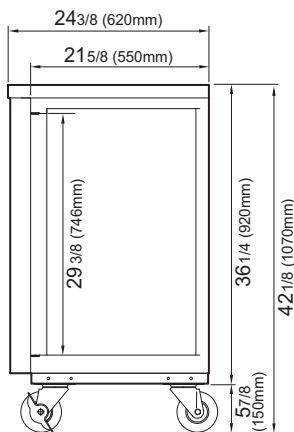

SIDE VIEW

Model

## BLNBB-60BG-SL-HC

Voltage	115V/60Hz
NEMA Config.	 NEMA 5-15P
AMPS	3.0
HP	1/3
Cord Length (ft.)	9.2
Refrigerant	R-290
Ext. Width (inches)(mm)	61 1/8 (1551mm)
Ext. Depth (inches)(mm)	24 3/8 (620mm)
Ext. Height (inches)(mm)†	36 1/4 (920mm)
Doors	2
Shelves	4
Net Capacity (cu. ft.)	15.6
6-pack of 12 oz Bottles	54
6-pack of 12 oz Cans	108
Net Weight	285 lbs. (130 kg)
Gross Weight	311 lbs. (141 kg)

Specifications subject to change without notice.  
† Height does not include 5-7/8" for caster height.

## Warranty



**3 Year Parts and Labor Warranty**  
**5 Year Compressor Warranty**

## Standard Features

- Four 4" diameter casters with front brakes.
- Self-contained system



223 W Rosecrans Ave., Gardena, CA 90248  
T. 310-808-0102

 blueairfse.com  
 orders@blueairfse.com