



223 W Rosecrans Ave., Gardena, CA 90248
T. 310-808-0102 www.blueairfse.com

Project:	
Location:	
Item #:	
Model #:	Qty:
AIA #:	SIS #:
CSI Section 11400	

Keg Cooler

Model
BLKC69-3S-HC

Model **BLKC69-3S-HC**



Cabinet Construction

- Stainless steel exterior with galvanized steel back and stainless steel interior
- High-density, foamed-in-place polyurethane insulation – environmentally friendly
- Two (2) 3" diameter stainless steel insulated beer towers (1 single-faucet, 1 double-faucet)
- Four (4) 4" diameter swivel casters with front brakes standard

Refrigeration

- Front-breathing, side-mounted compressor for efficient operation in tight spaces and easy service access
- Forced-air cooling system maintains consistent temperature throughout the cabinet for reliable performance
- Automatic defrost system minimizes maintenance and ensures stable operation

Hydrocarbon refrigerants (R-290)

- Hydrocarbon refrigerant (R-290) increases energy efficiency and does not deplete the ozone layer

Doors

- Black recessed door handles
- Durable gasket with easy replacement
- Standard door locks

Design & Features

- LED interior lighting
- Digital temperature control with real-time monitoring
- Optimized airflow for consistent cooling performance
- Top-mounted beer tower design for efficient dispensing workflow
- Maintains cabinet temperatures of 34°F to 38°F for optimal beverage preservation



Model	Doors	Shelves	Capacity (Cu.ft.)	HP	AMPS	W x D x H [†] (inches)	Crated Weight (lbs.)
BLKC69-3S-HC	2	-	20.4	1/3	3.0	69 x 27 ^{5/8} x 37	376

Keg Cooler

PLAN VIEW

(Unit: inches)

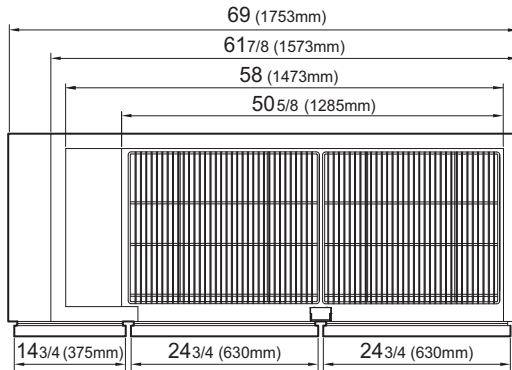

TOP VIEW

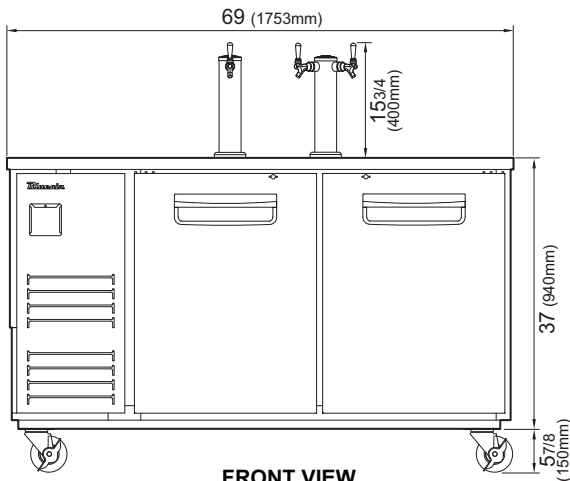

FRONT VIEW

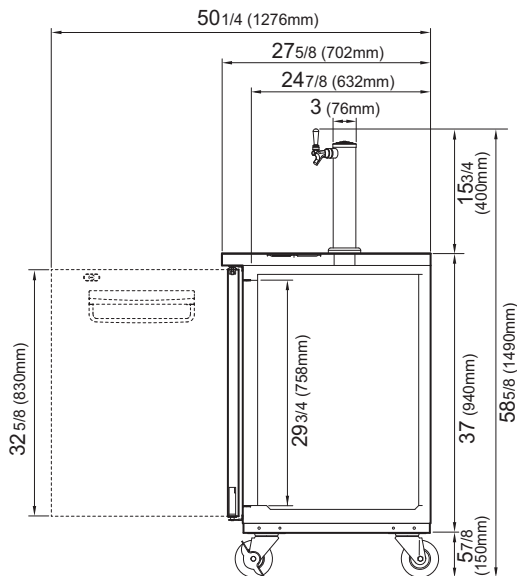

SIDE VIEW

Model

BLKC69-3S-HC

Voltage	115V/60Hz
NEMA Config.	 NEMA 5-15P
AMPS	3.0
HP	1/3
Cord Length (ft.)	9.2
Refrigerant	R-290
Ext. Width (inches)(mm)	69 (1753mm)
Ext. Depth (inches)(mm)	27 5/8 (702mm)
Ext. Height (inches)(mm)†	37 (940mm)
Doors	2
Shelves	-
Net Capacity (cu. ft.)	20.4
Barrels (1/2)	3
Net Weight	330 lbs. (150 kg)
Gross Weight	376 lbs. (171 kg)

Specifications subject to change without notice.

† Height does not include 5-7/8" for caster height. Height does not include 15-3/4" for draft arm.

Warranty



3 Year Parts and Labor Warranty
5 Year Compressor Warranty

Standard Features

- Two (2) beer towers (1 single-faucet, 1 double-faucet)
- Four (4) 4" diameter casters with front brakes
- Door locks
- Self-contained refrigeration system



223 W Rosecrans Ave., Gardena, CA 90248
T. 310-808-0102

 blueairfse.com
 orders@blueairfse.com