



223 W Rosecrans Ave., Gardena, CA 90248
T. 310-808-0102 www.blueairfse.com

Project:	
Location:	
Item #:	
Model #:	Qty:
AIA #:	SIS #:
CSI Section 11400	

Keg Cooler

Model
BLKC23-1B-HC

Model **BLKC23-1B-HC**



Cabinet Construction

- Stainless steel top with black powder-coated steel exterior and stainless steel interior
- High-density, foamed-in-place polyurethane insulation – environmentally friendly
- One (1) 3" diameter stainless steel insulated beer tower (single-faucet)
- Four (4) 3" diameter swivel casters with front brakes standard.

Refrigeration

- Forced-air cooling system maintains consistent temperature throughout the cabinet for reliable performance
- Automatic defrost system minimizes maintenance and ensures stable operation

Hydrocarbon refrigerants (R-290)

- Hydrocarbon refrigerant (R-290) increases energy efficiency and does not deplete the ozone layer

Doors

- Black recessed door handles
- Durable gasket with easy replacement
- Standard door lock

Design & Features

- LED interior lighting
- Digital temperature control with real-time monitoring
- Optimized airflow for consistent cooling performance
- Top-mounted beer tower design for efficient dispensing workflow
- Maintains cabinet temperatures of 34°F to 38°F for optimal beverage preservation



Model	Doors	Shelves	Capacity (Cu.ft.)	HP	AMPS	W x D* x H† (inches)	Crated Weight (lbs.)
BLKC23-1B-HC	1	-	8.1	1/4	3.0	24 ¹ / ₈ x 29 ⁷ / ₈ x 34 ⁷ / ₈	161

Keg Cooler

PLAN VIEW

(Unit: inches)

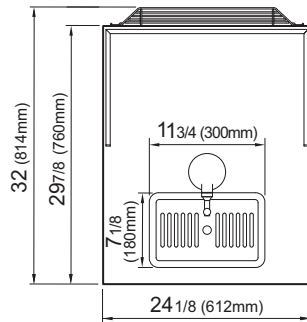

TOP VIEW

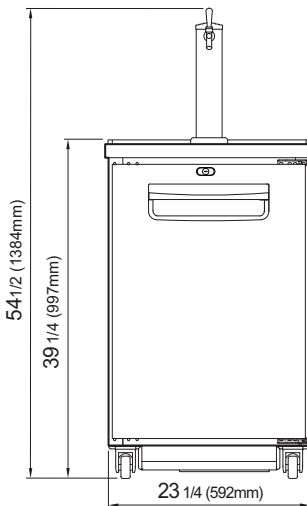

FRONT VIEW

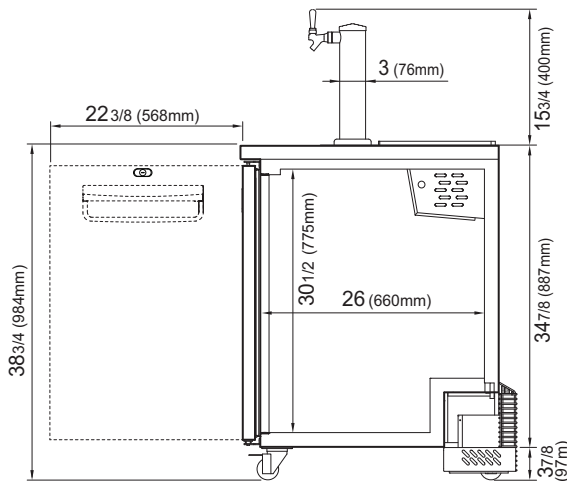

SIDE VIEW

Model

BLKC23-1B-HC

Voltage	115V/60Hz
NEMA Config.	 NEMA 5-15P
AMPS	3.0
HP	1/4
Cord Length (ft.)	9.2
Refrigerant	R-290
Ext. Width (inches)(mm)	24 1/8 (612mm)
Ext. Depth (inches)(mm)*	29 7/8 (760mm)
Ext. Height (inches)(mm)†	34 7/8 (887mm)
Doors	1
Shelves	-
Net Capacity (cu. ft.)	8.1
Barrels (1/2)	1
Net Weight	139 lbs. (63 kg)
Gross Weight	161 lbs. (73 kg)

Specifications subject to change without notice.

*Depth does not include 2" for rear mechanical components.

† Height does not include 3-7/8" for caster height. Height does not include 15-3/4" for draft arm.

Warranty

3 Year Parts and Labor Warranty
5 Year Compressor Warranty

Standard Features

- One (1) single-faucet beer tower
- Four (4) 3" diameter casters with front brakes
- Door lock
- Self-contained refrigeration system



Blueair
FOOD SERVICE EQUIPMENT

223 W Rosecrans Ave., Gardena, CA 90248
T. 310-808-0102

 blueairfse.com
 orders@blueairfse.com