



223 W Rosecrans Ave., Gardena, CA 90248
T. 310-808-0102 www.blueairfse.com

Project:	
Location:	
Item #:	
Model #:	Qty:
AIA #:	SIS #:
CSI Section 11400	

Bottle Cooler

Model
BLBC-50B-HC

Model **BLBC-50B-HC**



Cabinet Construction

- Stainless steel top with black powder-coated steel exterior and stainless steel interior
- High-density foamed-in-place polyurethane insulation
- Polyethylene dividers included for organized product storage
- Interior height accommodates stacking of three "tall boy" beers
- Stainless steel slide top lid with locks
- Built-in bottle opener and cap catcher
- Four (4) 1-1/4" diameter roller casters

Refrigeration

- Front-breathing, side-mounted compressor for efficient operation in tight spaces and easy service access
- Forced-air cooling system maintains consistent temperature throughout the cabinet for reliable performance
- Automatic defrost system minimizes maintenance and ensures stable operation

Hydrocarbon refrigerants (R-290)

- Hydrocarbon refrigerant (R-290) increases energy efficiency and does not deplete the ozone layer.

Design & Features

- LED interior lighting for enhanced product visibility
- Digital temperature control with real-time monitoring
- Optimized airflow for consistent cooling performance
- Space-saving underbar design ideal for bar and beverage service operations
- Maintains cabinet temperatures of 34°F to 38°F for optimal beverage preservation



Model	Doors	Dividers	Capacity (Cu.ft.)	HP	AMPS	W x D x H [†] (inches)	Crated Weight (lbs.)
BLBC-50B-HC	2	2	13.7	1/4	3.3	48 ^{3/8} x 27 x 33 ^{1/4}	246

Bottle Cooler

PLAN VIEW

(Unit: inches)

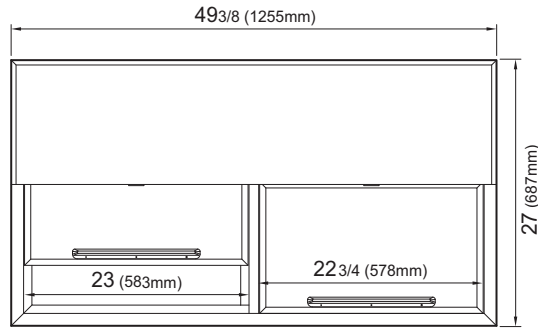

TOP VIEW

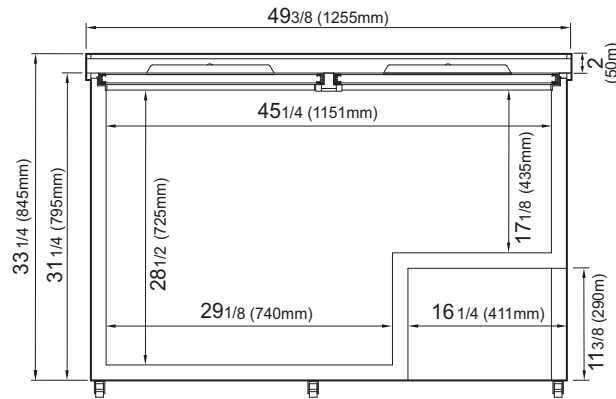

FRONT VIEW

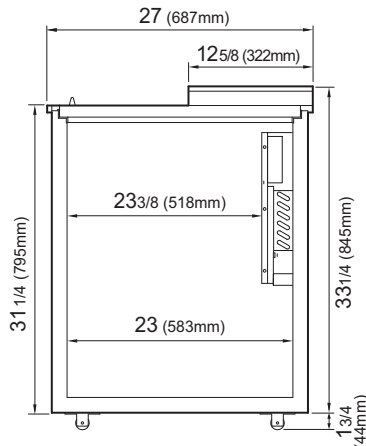

SIDE VIEW

Model

BLBC-50B-HC

Voltage	115V/60Hz
NEMA Config.	 NEMA 5-15P
AMPS	3.3
HP	1/4
Cord Length (ft.)	9.2
Refrigerant	R-290
Ext. Width (inches)(mm)	49 3/8 (1255mm)
Ext. Depth (inches)(mm)	27 (687mm)
Ext. Height (inches)(mm)†	33 1/4 (845mm)
Doors	2
Dividers	2
Net Capacity (cu. ft.)	13.7
6-pack of 12 oz Bottles	33
6-pack of 12 oz Cans	63
Net Weight	216 lbs. (98 kg)
Gross Weight	246 lbs. (112 kg)

Specifications subject to change without notice.

† Height does not include 1-3/4" for casters height.

Warranty



3 Year Parts and Labor Warranty
5 Year Compressor Warranty

Standard Features

- Four (4) 1-1/4" diameter roller casters
- Door locks
- Self-contained system



223 W Rosecrans Ave., Gardena, CA 90248
 T. 310-808-0102

 blueairfse.com
 orders@blueairfse.com