



223 W Rosecrans Ave., Gardena, CA 90248  
T. 310-808-0102 www.blueairfse.com

Project:	
Location:	
Item #:	
Model #:	Qty:
AIA #:	SIS #:
CSI Section 11400	

## Back Bar Cooler

Model  
**BLBB23-1BG-HC**

Model

**BLBB23-1BG-HC**



### Cabinet Construction

- Stainless steel top with black powder-coated steel exterior and stainless steel interior
- High-density, foamed-in-place polyurethane insulation – environmentally friendly
- Two (2) adjustable shelves
- Interior height allows stacking of three “tall boy” beers
- Four (4) 3” diameter swivel casters with front brakes standard

### Refrigeration

- Forced-air cooling system maintains consistent temperature throughout the cabinet for reliable performance
- Automatic defrost system minimizes maintenance and ensures stable operation

### Hydrocarbon refrigerants (R-290)

- Hydrocarbon refrigerant (R-290) increases energy efficiency and does not deplete the ozone layer.

### Doors

- Double-pane glass doors with black frames
- Vertical door handles for easy access
- Durable door gaskets with easy replacement
- Standard door locks

### Design & Features

- LED interior lighting for enhanced product visibility
- Digital temperature control with real-time monitoring
- Optimized airflow for consistent cooling performance
- Maintains cabinet temperatures of 34°F to 38°F for optimal beverage preservation



Model	Doors	Shelves	Capacity (Cu.ft.)	HP	AMPS	W x D* x H† (inches)	Crated Weight (lbs.)
BLBB23-1BG-HC	1	2	8.1	1/4	3.0	24 <sup>1</sup> / <sub>8</sub> x 29 <sup>7</sup> / <sub>8</sub> x 34 <sup>7</sup> / <sub>8</sub>	164

# Back Bar Cooler

## PLAN VIEW

(Unit: inches)

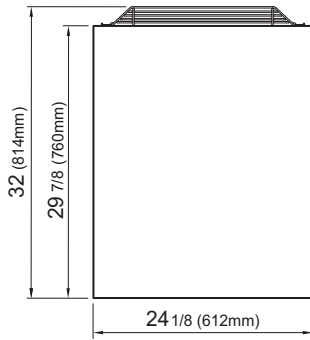

TOP VIEW

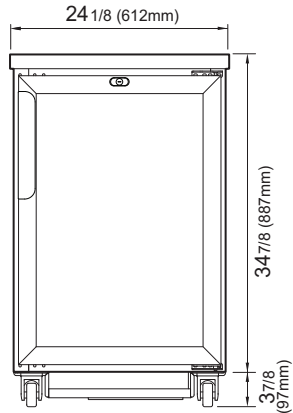

FRONT VIEW

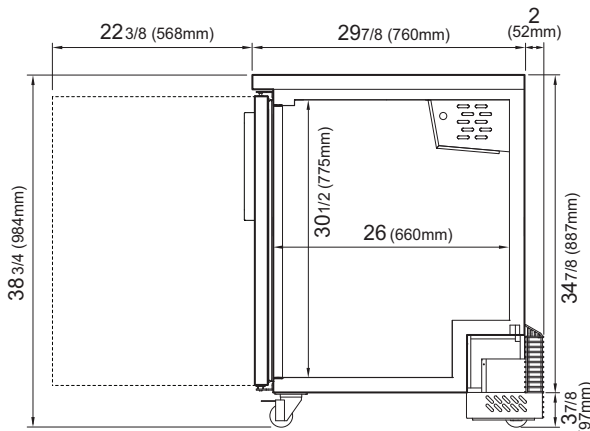

SIDE VIEW

Model

## BLBB23-1BG-HC

Voltage	115V/60Hz
NEMA Config.	 NEMA 5-15P
AMPS	3.0
HP	1/4
Cord Length (ft.)	9.2
Refrigerant	R-290
Ext. Width (inches)(mm)	24 1/8 (612mm)
Ext. Depth (inches)(mm)*	29 7/8 (760mm)
Ext. Height (inches)(mm)†	34 7/8 (887mm)
Doors	1
Shelves	2
Net Capacity (cu. ft.)	8.1
6-pack of 12 oz Bottles	22
6-pack of 12 oz Cans	36
Net Weight	142 lbs. (65 kg)
Gross Weight	164 lbs. (75 kg)

Specifications subject to change without notice.

\*Depth does not include 2" for rear mechanical components.

†Height does not include 3-7/8" for caster height.

## Warranty



**3 Year Parts and Labor Warranty**  
**5 Year Compressor Warranty**

## Standard Features

- Four (4) 3" diameter casters with front brakes
- Door lock
- Self-contained system



223 W Rosecrans Ave., Gardena, CA 90248  
 T. 310-808-0102

 blueairfse.com  
 orders@blueairfse.com