



**Stainless steel cabinet construction**

Stainless steel interior and exterior (galvanized steel back & bottom).



**Temperature range between 33°F ~ 39°F**

Air guard on rear wall ensures proper air circulation and cooling.



**Hydrocarbon refrigerants (R-290)**

Increases energy HFC refrigerants. It is safer for the environment and does not cause ozone depletion.



**Exterior Dimensions**  
(inches/mm)

L	D	H
60"	31"	25 1/2"
1524 mm	787.5 mm	648 mm

**Weight**  
(lbs/kg)

Net Weight	Ship Weight
231 lbs 105 kg	254 lbs 115 kg

**Cabinet construction**

- High density foamed in place polyurethane insulation – Environmentally safe
- Designed to accommodate countertop cooking equipment
- Unit accommodates 4" deep food pans. Pans not included
- Heavy duty top panel
- Four (4) 4" diameter swivel casters with front brakes standard.

**Refrigeration**

- Front breathing, side mounted compressor unit.
- Electrodeposition coated evaporator increases performance by maintaining the heat transfer rates over the life of the evaporator and reducing potential corrosion.
- Innovative hot gas frame heating system reduces condensation and increases energy.

**Drawers**

- Supported on stainless steel telescoping drawer slides with stainless steel roller bearing wheels
- Drawer slides withstand maximum of 200 lbs. per drawer without deflection
- Upper and lower drawers accommodate 4" deep 12" x 20" pans
- Heavy-duty pan adapter bars supplied for fullsize pans (Pans not included)
- Durable gasket with easy replacement
- Lifetime guaranteed heavy duty all metal door handles. (Ni-Cr Plated)
- 6" Legs available

Front view

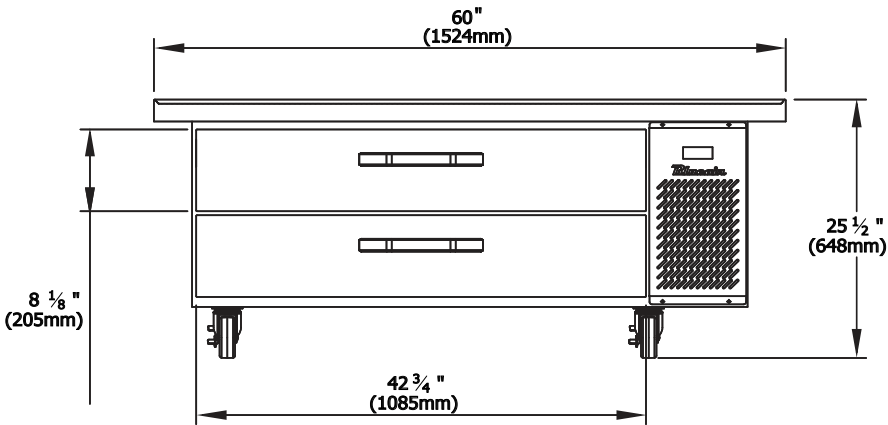



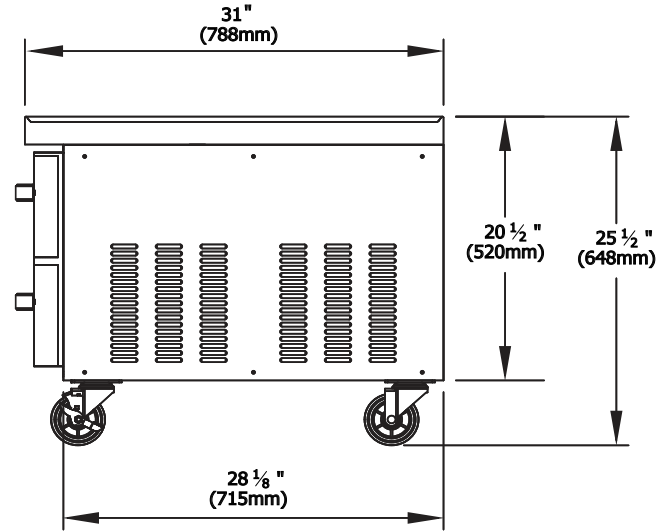

Side view

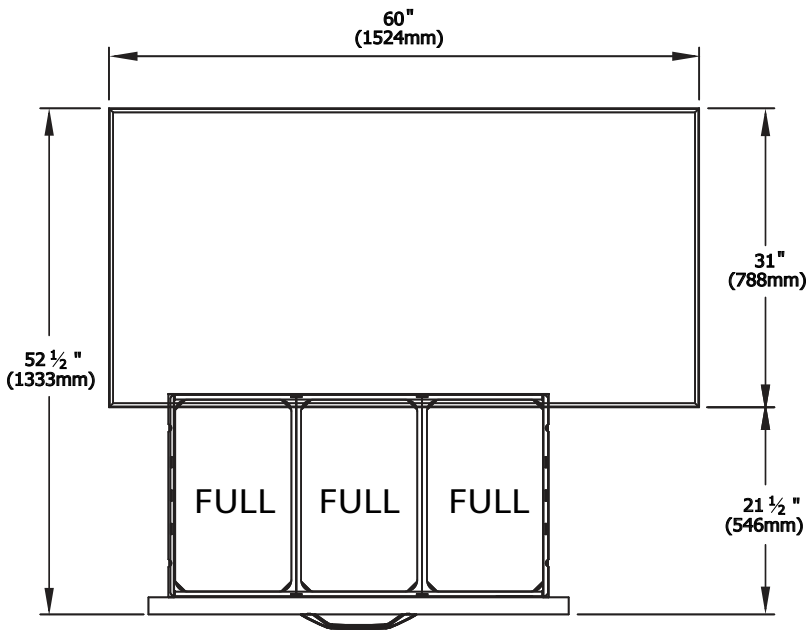

Top view



Drawers	2
Capacity Cu.Ft.	9.8
Refrigerant	R-290
Temperature Range	33°F ~ 39°F
Easy Maintenance	Sliding Condensing Unit
Connection	9.8 ft long (3m) flexible three wire cord with modeled plug
HP	1/4
Voltage	115V/60Hz
Amps	3.0
NEMA Config.	NEMA 5-15



- This product may expose you to chemicals including Diisononyl Phthalate(DINP), which is known to the State of California to cause cancer. For more information go to [www.P65Warnings.ca.gov](http://www.P65Warnings.ca.gov).  
 - Ce produit peut vous exposer à des agents chimiques incluant le Diisononyl Phthalate(DINP), reconnu par l'Etat de Californie comme causant le cancer. Pour de plus amples renseignements, consulter le site [www.P65Warnings.ca.gov](http://www.P65Warnings.ca.gov).



Blue Air has right to change specifications without further notice.



[blueairfse.com](http://blueairfse.com)



[orders@blueairfse.com](mailto:orders@blueairfse.com)



223 W. Rosecrans Ave., CA 90248  
T: 310-808-0102

9 W. Shelton Terrace #A, Hillside, NJ 07205  
T: 470-625-0182

7025 Amwiler industrial Drive, Suite A, Atlanta GA  
T: 908-688-0970