

GVH Visual Hopper Grinder



Model GVH-1

Dimensions: 23.1" H x 7" W x 15.8" D
(58.7cm H x 17.8cm W x 40.1cm D)



Model GVH-2

Dimensions: 24.6" H x 7" W x 15.8" D
(62.5cm H x 17.8cm W x 40.1cm D)



Model GVH-3

Dimensions: 25.8" H x 7" W x 15.8" D
(65.5cm H x 17.8cm W x 40.1cm D)

Features

Visual Hopper Grinder

- New sleek styling with visual hopper promotes freshly ground coffee
- Versatile design allows grinding into bags, cans, and cups and other containers to meet a multitude of customer needs
- Fast grinding – one pound (.45kg) in about 30 seconds – maximizes speed of service
- 340° dial resolution for precise tuning of grind particle size
- Ergonomic clamp for holding smaller size bags and containers in place for hands-free operation
- Easy to use cleaning lever for complete removal of coffee from grind chamber ensures the customer gets all the coffee ground for them
- Precision Rockwell 65C hard burrs provide consistency, grind after grind
- Bag switch prevents grinding before bag/container is in place
- Four-year warranty on grinding burrs

Related Products

Precision Burrs

All BUNN grinders use precision burrs to cut (not crush) the coffee beans and deliver consistent grind distribution. BUNN burrs are rated at a Rockwell hardness of 66C, resulting in an exceptionally long burr life.

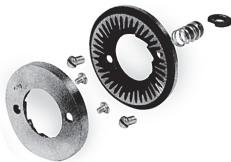

Standard Grind Burr Set

Product No: 05861.1002

Fine Grind Burr Set

Product No: 11285.1000

Fine Grind Dechaffer Kit

Product No: 43724.0000

Standard Dechaffer (2 required)

Product No: 20588.0000

Model

GVH

Agency Listing



Dimensions & Specifications



Model	Product #	Volts	Amps	Capacity lbs/kg	Cubic ft ³ /m ³	Weight lbs/kg	Cord Attached
GVH-1	55600.6100	120	11	1 lbs/.45 kg	1.47/.04	56.2 lbs/25.4 kg	Yes*
GVH-2	55600.6200	120	11	2 lbs/.90 kg	1.57/.04	56.2 lbs/25.4 kg	Yes*
GVH-3	55600.6300	120	11	3 lbs/1.36 kg	1.65/.04	56.2 lbs/25.4 kg	Yes*

Electrical: 2-wires plus ground service rated 120V, 60Hz, circuit required, ¾ HP motor. Plug type: NEMA 5-15P

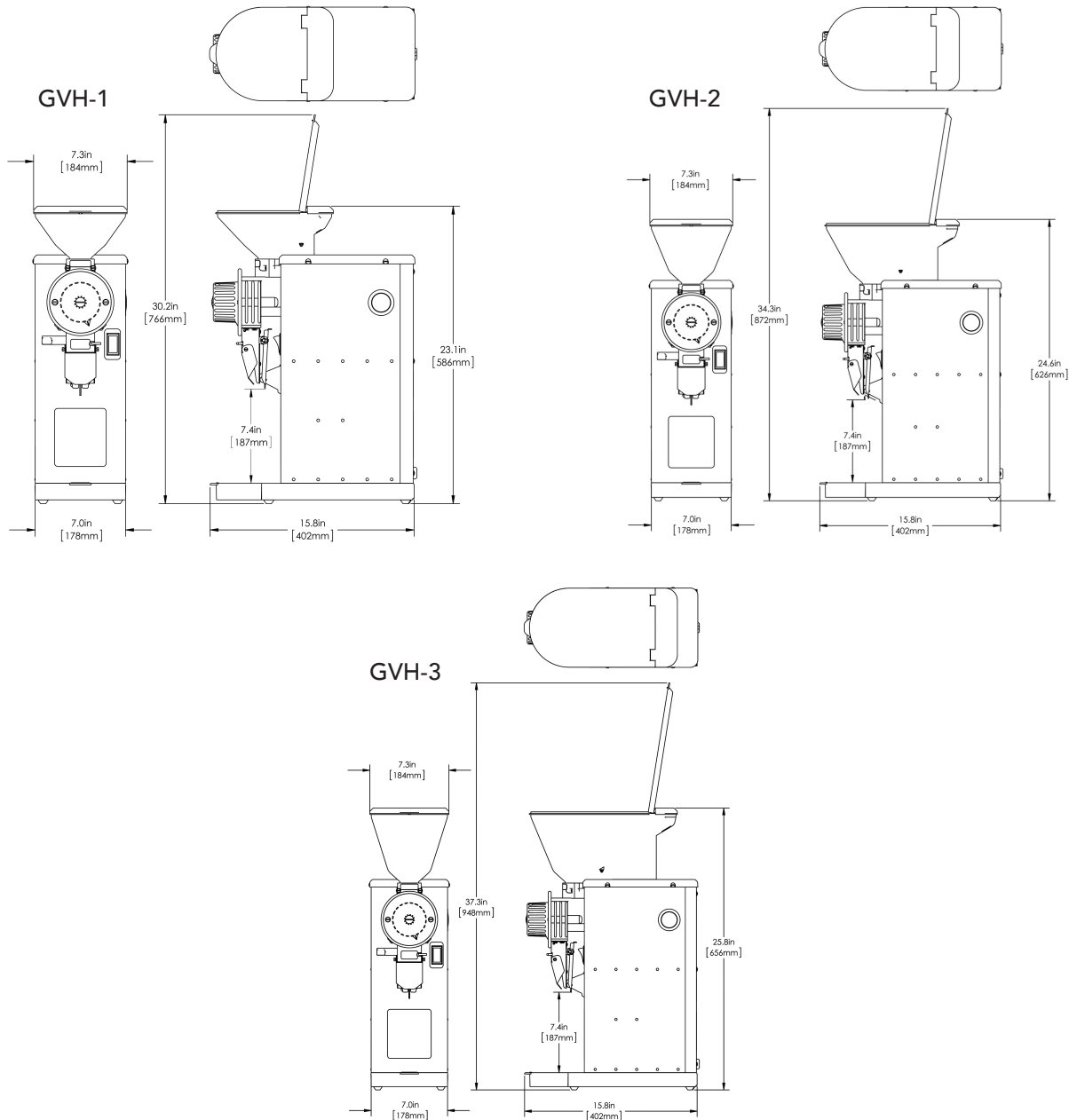

Bunn-O-Matic® Corporation of Canada • 280 Industrial Pkwy South, Aurora Ontario. L4G 3T9 • (905) 841-2866 • www.bunn.com

BUNN® practices continuous product research and improvement. We reserve the right to change specifications and product design without notice. Such revisions do not entitle the buyer to corresponding changes, improvements, additions or replacements for previously purchased equipment.

All dimensions shown in centimeters.