

Infusion Series 1.5 Gal (5.7L) Soft Heat[®] Server



Infusion Series 1.5Gal (5.7L) SH Server

Dimensions: 14.5" x 9.1" x 13.3"
(36.7cm x 23cm x 33.7cm)

Features

- BUNN-exclusive Soft Heat server technology automatically docks to the brewer to supply controlled heat to brewed coffee with holding temperatures ideal for optimal flavor for longer periods
- New 1.5gal (5.7L) Soft Heat servers are completely modernized, ergonomic, lighter weight and energy efficient, but still constructed of durable stainless steel to withstand the demands of a busy serving environment
- Programmable recipe/batch-based holding times and temperatures
- Integrated sight gauge assembly provides at-a-glance volume level
- Unit alerts staff when freshness has expired or server is empty
- Optional Soft Heat Docking Stand easily creates satellite serving options with multiple servers where heat can continue to be automatically managed through instant power contact in the Stand

Related Products

Twin SH Brewer

Product No. : 51200.6101



1SH Stand

Product No. : 27825.6200



2SH Stand

Product No. : 27875.6200



Model

Infusion SH Server

Agency Listing



Dimensions & Specifications

CANADA 

Model	Product #	Volts	Amps	Tank Htr Watts	Total Watts	Capacity	Cubic ft ³ /m ³	Weight lbs/kg
Infusion SH Server 1.5gal	27850.6200	-	-	-	-	1.5gal/5.7L	1.69/0.04	9.55/4.33

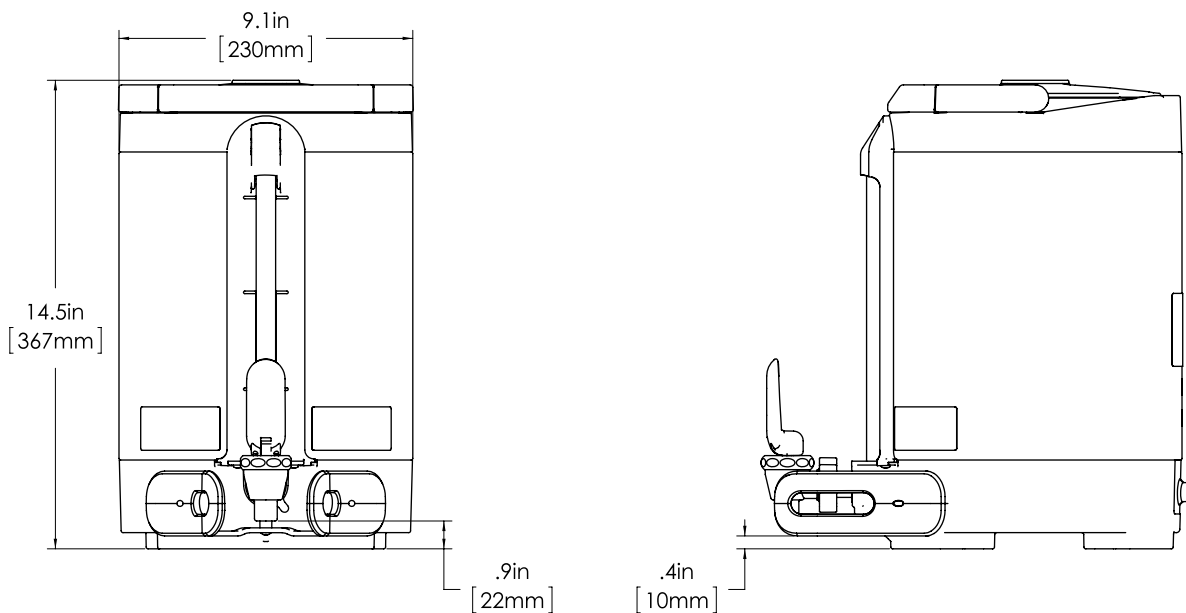
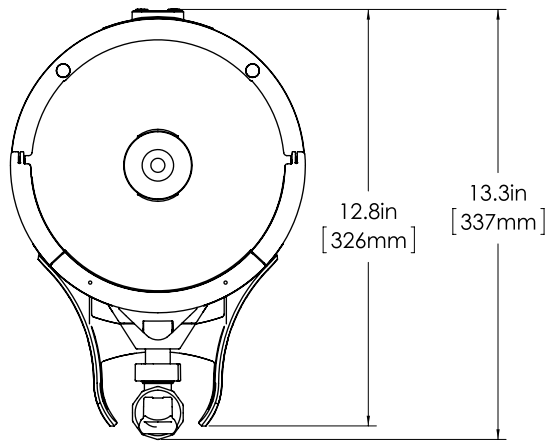

Bunn-O-Matic® Corporation of Canada • 280 Industrial Pkwy South, Aurora Ontario. L4G 3T9 • (905) 841-2866 • www.bunn.com

BUNN® practices continuous product research and improvement. We reserve the right to change specifications and product design without notice. Such revisions do not entitle the buyer to corresponding changes, improvements, additions or replacements for previously purchased equipment.