

WX2 Warmer

Features

Warmer

- Capacity for 2 servers
- Stainless finish



WX2 Warmer

Dimensions: 2.5" x 14.5" x 7.0"
(6.4cm x 36.8cm x 17.8cm)

Related Products

Model

WX2 Warmer

Agency Listing



Dimensions & Specifications

CANADA



Model	Product #	Volts	Amps	Total Watts	Capacity	Cubic ft ³ /m ³	Weight lbs/kg	Cord Attached
WX2	06310.6000	120	1	100	2 servers	.14/.004		Yes

Electrical: Requires 2-wires plus ground service rated 120/240V, single phase, 60Hz. Supplied with a cordset and a NEMA 5-15P plug. Receptacle is not included (NEMA 5-15P).

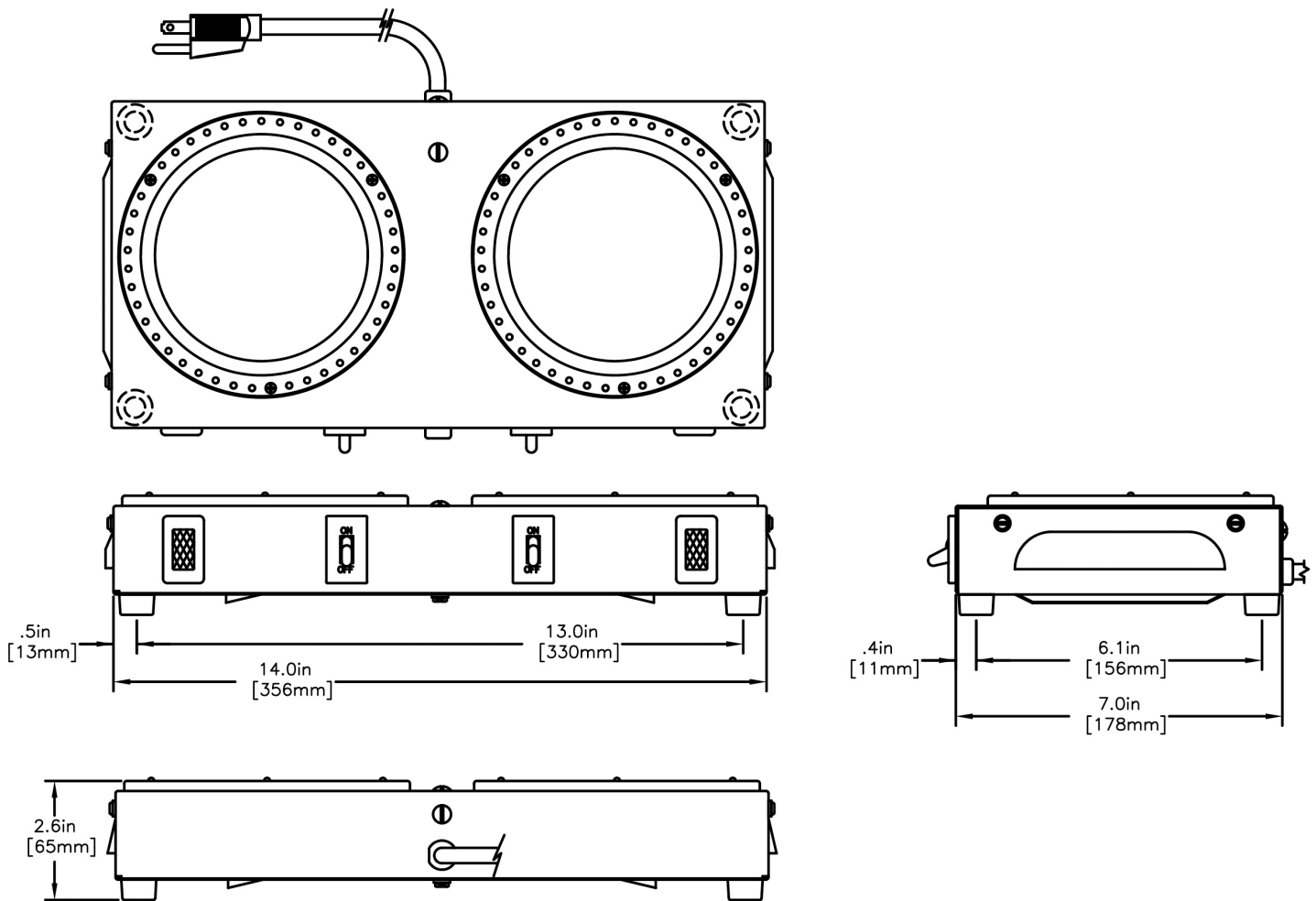

Bunn-O-Matic® Corporation of Canada • 280 Industrial Pkwy South, Aurora Ontario. L4G 3T9 • (905) 841-2866 • www.bunn.com

BUNN® practices continuous product research and improvement. We reserve the right to change specifications and product design without notice. Such revisions do not entitle the buyer to corresponding changes, improvements, additions or replacements for previously purchased equipment.

All dimensions shown in centimeters.